

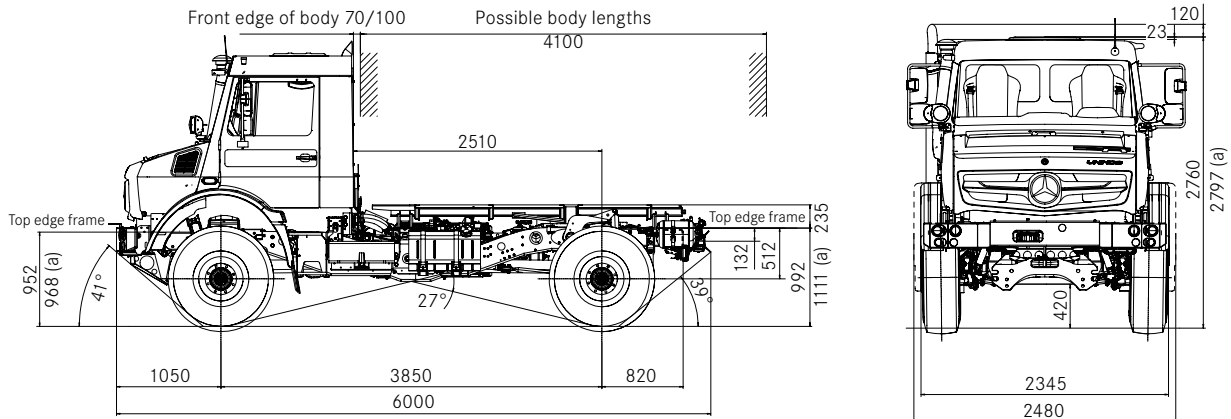

Mercedes-Benz
Trucks you can trust

Technical data

Mercedes-Benz Unimog U 4023



(a) Unladen vehicle

Vehicle with loaded suspension, with 335/80 R20 tires, optional equipment and partially laden condition.

All dimensions in [mm]

Model	U 4023
Engine (Euro VI)	OM 934 LA
Output	170 kW/231 hp
Torque	900 Nm/1400 rpm
Clutch	SAE-2 Ø 395 mm Single-plate dry clutch (organic)
Transmission	UG 100/8
Axles	Torque tube linked portal axles with coil springs
Front axle (model type)	737.367
Rear axle (model type)	747.367
Electrical system	24 V
Battery capacity (Series/SA)	100/170 Ah
Tank capacity	Rated volume 160/235 l
Steering with max. steering pressure	ZF 8095/170 bar
Brakes	Pneumatic disc brakes
Smallest tyres (tyres/rim)	335/80 R20
Largest tyres (tyres/rim)	425/75 R20 and 405/70 R24
Type of drive	Engageable all-wheel drive
Wheelbase	3850 mm
Max. weight (with corresponding optional extras)	10.3 t
Max. weight on front axle	4.6 t
Max. weight on rear axle	6.0 t
Angle of approach/departure	41°/39°
Turning circle Ø	16.3 m
Body mounting area (recommended length × width × height)	4100 × 2280 × 1400 mm
Fording depth (Series/SA)	0.8 m/1.2 m
Speed	89 km/h*

* Limited, legal speed limit