

Swadro

Rotary Rakes

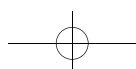

www.krone.de

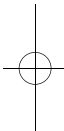
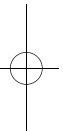

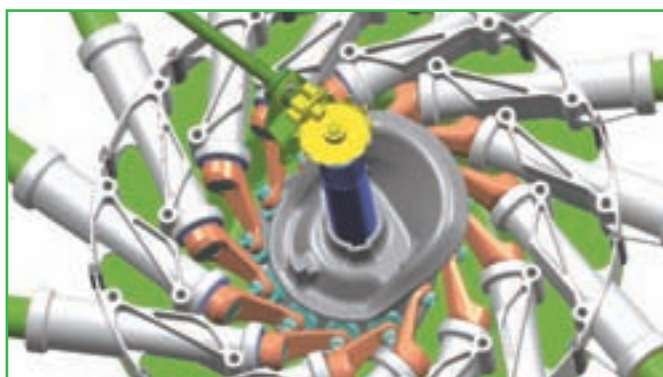

The rotor Depend on it

Design and functionality of a sealed rotor



Swadro 35, 38, 42, 46

Three-point linkage single-rotor rake working at widths from 3.50 m (11'6") to 4.60 m (15'1")

Swadro 38 T, 42 T, 46 T

Trailed single-rotor rake working at widths from 3.80 m (12'6") to 4.60 m (15'1")



Swadro 700, 800/26, 900, 700 Plus, 800/26 Plus, 900 Plus, 1000

Trailed two-rotor center-delivery rake working at widths from 6.80 m (22'4") to 10.00 m (32'10").



Swadro 710/26 T

Trailed twin-rotor side-delivery rakes working at widths of 6.20 m (20'4") in single windrow presentation or at widths of 2 x 3.40 m (2 x 11'2") in double windrow presentation



Swadro 807, 810, 907

Trailed twin-rotor side-delivery rakes working at widths from 6.20 m (20'4") to 8.00 m (26'3") for single windrow presentation

Swadro 810 offers an extra setting option for double windrow presentation from 2 x 3.70 m (2 x 12'2") in one pass



Swadro 1010

Trailed triple-rotor side-delivery rake working at 9.70 m (31'10") width



Swadro 1400, 1400 Plus

Trailed four-rotor center-delivery rake working at widths from 11.00 to 13.50 m (36'1" - 44'4")



Swadro 2000

Trailed six-rotor center-delivery rake working at widths from 10.00 m to 19.00 m (32'10" - 62'4")





One can count on

- Fluid grease filled rotor drive gearboxes
- Enclosed rotor housings: completely maintenance-free
- Rotor and tine arms free of grease nipples
- Dura-Max, the double hardened cam track
- Tine arms with extra strong profile tube



In order for work to run smoothly in the field, competent preliminary construction work must have been performed. High quality, excellent workmanship and innovative details are characteristic for all KRONE products. Of course, this is also true for the Swadro model rotary rakes – the name synonymous for performance and smooth output.



Dura-Max: the cam-track, double hardened and impact resistant strength, is made from Bainite-hardened cast iron to ensure a high abrasion resistance while being completely maintenance-free. This cam-track comes with a three-year warranty.



For perfect swathing: the control of the tine arms is performed via large dimensioned, sealed for life cam follower rollers. The contour of the cam track stands for smooth performance and exemplary formed box-shaped windrows.

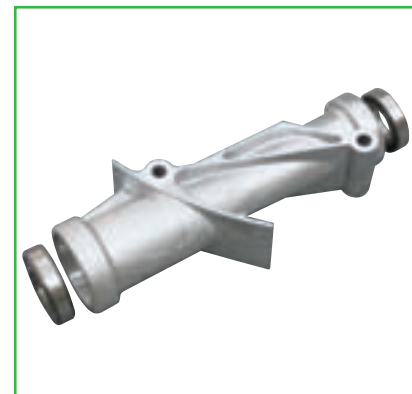

Innovative: the tine mounting bearing cases are made of aluminium. This saves weight and still guarantees the highest of rigidity. The large spacing between the grooved ball bearings increases load capabilities – a clear advantage when in heavy crops.



Grease nipples on the gearbox, the cam-track, or on the tine arms? No thank you! KRONE rotary rakes not only provide an optimum of performance, but of course, also when maintenance is concerned, the cam-track, cam follower rollers and the tine arm bearings all operate in an enclosed housing and require no maintenance. The Dura-Max special hardened cam-track, the large cam follower rollers, the extra strong tubular tine arms and their bearings in aluminium housings are built to withstand the highest of forces in heavy forage and thus increase profitability.

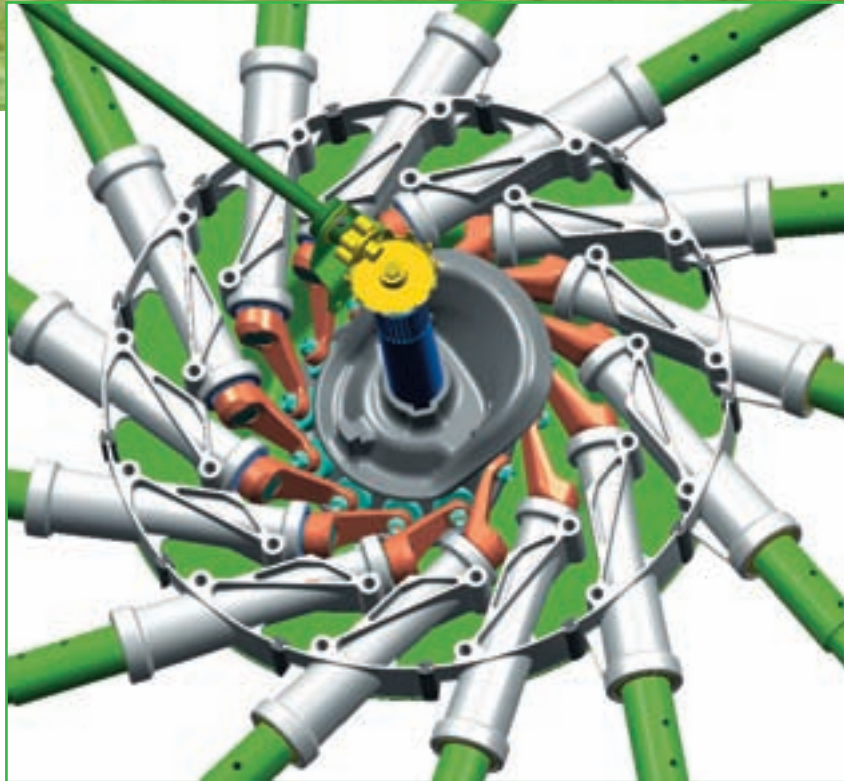

Quick and simple: assembly and disassembly of the complete tine arm with bearing and cam follower roller. After removing only two bolts the complete unit can be pulled out of the rotor. The removal of two hollow roll pins means that the outer end of the arm can also be exchanged.



Cleanest sweeps – up to five double tines on each tine arm give a trailing action for cleanest rakes. Thick-walled arms and up to 10.5 mm (0.4") tines plus large-diameter coils combine to guarantee outstanding longevity, flexibility and strength.

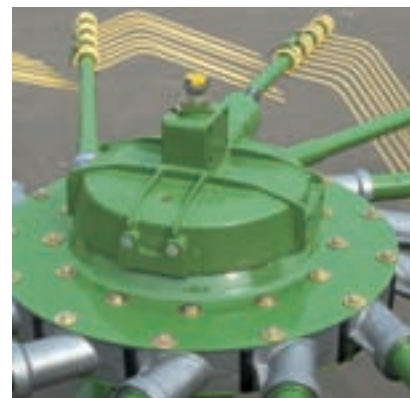

Maintenance-free and continuously lubricated: The Swadro rotors are driven via completely enclosed, liquid grease filled bevel gear drives. This ensures uniform and optimum lubrication and further lubrication via a grease gun is not necessary.



SWADRO 35, 38, 42, 46

Three-point linkage mounted Single Rotor Rakes

- Tandem axle as standard equipment
- Shock absorbing link-rods with interior compression springs
- Self-centralizing when raised
- Fold-in tine arms



Feels at home in many applications: the three-point linkage mounted Swadro single rotor rakes with working widths of 3.50 m to 4.60 m (11'6" to 15'1"). Their exemplary robustness and unique technology are convincing and offer many of the technical features proven in the KRONE large-scale rakes.



On big tires: the Swadro single rotary rake is optimally equipped with its 16 x 6.50, 6 ply super balloon tires. These tires offer excellent running and soft treading to protect the turf.

This one balances out: the Swadro single rotary rakes have a tandem axle as standard equipment with the wheels mounted as close to the rotating tines as possible. This guarantees the best contour following and cleanest raking on uneven ground.

Absolutely clean. Nothing is left behind on the ground, not even in heavy silage. A pin/hole setting system adjusts rotor tilt on either side of the rotor.



It starts with the running gear: The larger the rotor diameter the more important the running gear becomes. For clean raking the tines must travel across the entire working width at a uniform height above the ground. Ground unevenness or ridges may cause forage contamination, which in turn can lead to a severe deterioration in silage quality. For this reason KRONE offers balanced tandem axles as standard equipment on its range of single rotor rotary rakes. For a much improved contour following a front support wheel is available as optional equipment.



Perfect in work: using up to 13 tangentially arranged tine arms, the SWADRO 35 to 46 single rotor rakes deposit the crop in clean, even swaths.



Perfectly guided: an additional, height adjustable castor support wheel is available as an option so that when fitted the rotor is aligned even better to the ground contours especially on undulating ground.



Optimally controlled: different top link pin positions ensure the optimum guidance of the rotor under any condition. When utilizing the front support wheel the elongated hole is chosen for the top link for additional float potential.



Easy adjustment: the final adjustment of the working height of the rotor is infinitely adjustable. This is being done quickly and easily from the tractor seat by means of a crank handle. The result is clean crop transfer without anything left behind.



Flexible and agile. This rake does a clean job. With a steering angle of 20° the corners are also covered as the following rotor will not miss anything forming perfect windrows, even in the corners. This is a key advantage, because KRONE Swadro single rotor rakes are often utilized in small, winding fields.

Tracks true: In any curve KRONE Swadro single rotor rakes always follow the tractor.



Always the optimal windrow width: the adjustment of the swath curtain is simple. Depending not only on the heaviness of the crop, but also on the desired windrow width, the swath curtain can easily be extended or retracted via a telescopic link arm.



Exclusive: The patented tracking system steers the KRONE rakes through the tightest turns. A swing combined with accumulator arms implements a steering angle of about 20° for excellent maneuverability and large lift-out height.



Damped is better: shock-absorbing link rods ensure a smooth trailing action under all conditions, in curves, at high speeds, as well as when raking downhill.



Safe on the road: high traffic volumes and faster tractor speeds make high demands on mounted machinery with regard to traffic safety. KRONE rakes meet these demands fully. With folded tine arms and a fold-away swath curtain Swadro single rotor rakes are quite compact and can be converted for road transport quickly and safely.



Competent in the field, compact on the road: these properties are characteristic of all rotary rakes from KRONE.



Comfortable and automatic: the machine is lifted for transport. For this purpose, the shock-absorbers come to a stop and secure the rotor in the center position behind the headstock. No securing the rake by hand is necessary.



Practical: a large over-dimensioned tension spring eases the lifting of the swath curtain up into the transport position. Simultaneously, the rotor is prevented from turning by a locking strap. This ensures the low transport width with its laterally folded tine arms is maintained.



Easy as pie – wide in the field, narrow on the road: the outer tine arms are folded in for road transport. This is done quickly and easily – effortlessly.



Swadro 38 T, 42 T and 46 T

Trailed single-rotor rakes

- Large working width
- Low power requirement
- Drawbar with parallelogram control
- Easy hitching on and off
- Tandem axle with 18" tires as standard equipment
- Swadro 38 T and 42 T are marketed in export markets only



KRONE added the Swadro 38 T, 42 T and 46T models to its range of rakes to meet farmer demands at home and abroad. The demand is for a trailed and well-proven single-rotor rake that offers the well-proven Swadro technology. The tandem axle on these models serves also as transport running gear on public roads.



Jammed on the drawbar? This won't happen with the parallelogram controlled, height adjustable drawbar for the tractor drawbar or pick-up hitch. The hydraulic ram on the drawbar levels the rotor during lift and lowering.



Aiming high: the lifting of the rotor is done hydraulically. The construction of the tandem running gear and the lifting cylinder linkage means a high ground clearance of around 600 mm (2') – ideal for driving over already deposited windrows.



Everything is picked up: the adjustment of the working height is simple and is done via extendable, adjustable supports where a simple pin and clip is slipped into a series of holes.



The output of a single-rotor rake is not limited by lack of pto power but by the fact that the machine takes too much load off the tractor's front axle as it is raised out of work. The answer to this problem is Swadro 38 T, 42 T and 46 T. These trailed models suit small and light tractors and applications in sloping fields. They stand out for low tractor power input and easy attachment and removal – either via floating or linkage drawbar.



Quickly and safely down the road at 40 km/h (25 mph): this can also be achieved with a small tractor. The machine does not affect tractor steering. No load is taken off the front axle.



The tandem axle with large dimensioned 18" super balloon tires as standard equipment: Even in heavy forage crops everything is picked up, the transverse rotor angle can also be fine-tuned via a spindle.



For the best results when raking in all conditions: the optional front support wheel. It trails – which is ideal for tight curves. The working height can be easily adjusted with a pin adjustment in a hole segment.



Narrow transport width: The tine arms on the sides of Swadro 46 T fold up easily to provide a compact transport width and safe travel.



Swadro 700, 800/26, 900

The professional center delivery Rakes

- KRONE-Jet-Effect 
- Cardanic rotor suspension
- Choice of mechanical or hydraulic work width control on Swadro 800/26 and 900
- Separate rotor lift/lower feature on Swadro 800/26 and 900

In order for work to run smoothly in the field, competent design and build quality must be right from the start. With KRONE you can rest assured that you will always have to hand first-rate machinery, the technology of which is impressive. This is also true for the KRONE center delivery rakes with working widths of 6.80 to 8.80 m (22'4" to 28'11"). They are easy to service and maintain, work-hungry, yet gentle on both forage and swath.



The basis for a long service life: The Cat I and II lower link hitch points are solidly designed and the headstock connected via the pendulum suspension. The PTO shaft cannot be damaged by inadvertently lifting the lower link arms.



A single axled undercarriage for the Swadro 700 with 18 x 8.50 – 8/6 PR-RT tires comes as standard equipment: the large tires of the extra wide axle run closely to the working tines, which is ideal for clean raking.



Wide track: the tridem axle is gentle on the swath and makes for clean forage. The front wheels are castor-steered and connected to a track rod. This results in smooth running whereas the fixed rear wheels stabilize the driving behavior on slopes.



Gentle and efficient: a center delivery rake provides advantages, where forage quality is concerned. It operates in a very clean fashion, because the forage is handled from both sides only across one rotor width. The box-shaped, extremely uniform windrows are ideal for feeding into following harvesting machinery. With a center delivery rake, one can drive fast and achieve a large raked area. The Swadro 900 with its big diameter rotors and 13 tine arms on each is a high output machine easily attaining work-rates of approximately 8.5 hectares (21 acres) per hour. The Swadro 700, 800, and 900 are highly impressive with their simple operation, very good driving and tracking properties and their compact, clearly arranged design.



Clean: because the forage is handled by only one rotor. KRONE Swadro twin rotor center delivery rakes deposit the forage in an airy, loose manner without any roping.



Adjusting rotor tilt: Rotor depth is adjusted on depth holes. The system is easy to handle and sets the depth separately on the rear wheels of the tridem axle. As a result, nothing is left behind, even in the heaviest crop



Cornering smoothly – castoring rear wheels are available as an option for the tridem axles. Tracking excellently in headland turns, these wheels eliminate the risk of scuffing, protect the turf and take off stress from the running gear.



Perfect guidance – extra wheels are available as an option for the tridem axle to allow the rear axle to run like a tandem assembly, hugging the ground and enabling cleanest rakes from large rotors.

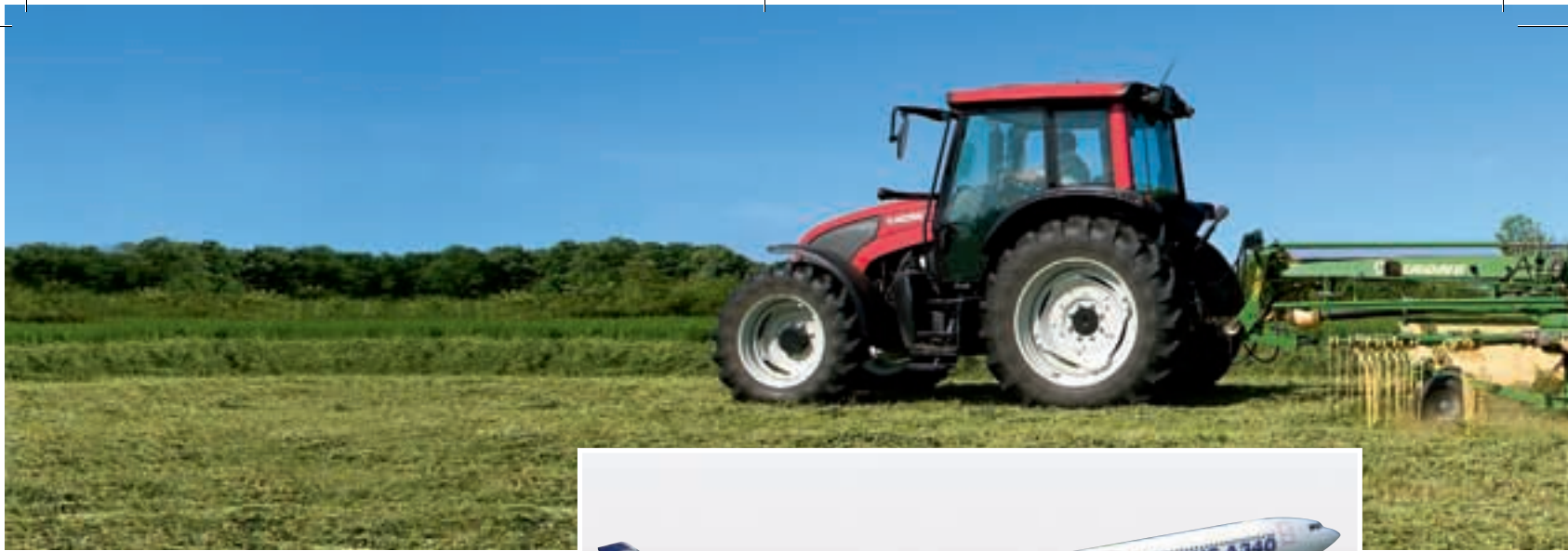

The KRONE Jet Effect: clean landing, clean start! The trailing rotor linkage, combined with the cardanic suspension, makes perfect sense: as when the rotor is lowered, the rear wheels of the tridem axle touch the ground first and then the front wheels – when lifting this occurs in the reverse order. This is why the tines are unable to drop into the ground, damaging the windrow or contaminate the forage during the lowering and lifting process. This KRONE solution guarantees high quality forage.

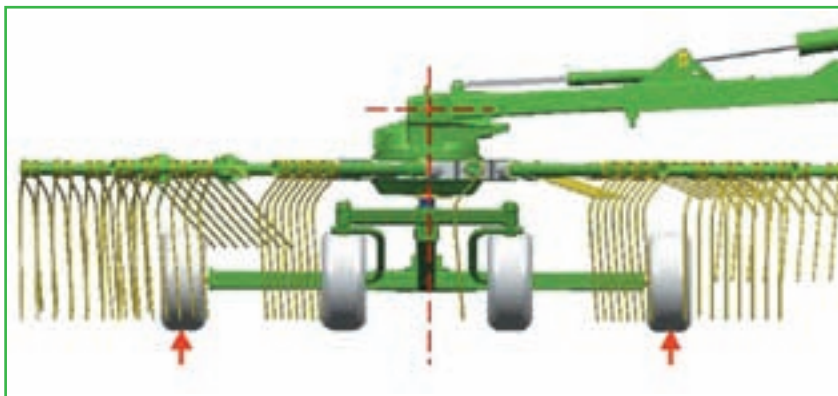

Using equal ground pressure across the entire width: because the rotor is suspended from a central position over the main rotor gearbox the tines leave the ground parallel to the transverse driving direction during lifting. The result: central suspension stands for clean forage.



Trailing rotors: The rotor mounts in a position behind its arm. This design combines with its cardanic suspension system to give ideal lift-out control and avoid damage to the windrow.



Using professional machinery is a must if you seek high-quality forage. Contractors and large-scale farmers not only look for large area outputs without losses but also for a high quality of work, which is a critical factor in the profit equation. The KRONE rotary rake models Swadro 700, 800/26 and 900 feature a high number of clever details that cater for exactly these requirements – cardanic rotor attachment, tridem axles, four reinforced 10.5 mm (0.4") diameter double tines on each arm and cranks adjusting the rotors to accurate work depths.



With the KRONE Swadro 700, 800/26, and 900 twin rotor rakes one can rest assured of a smooth running of the basic foraging process.

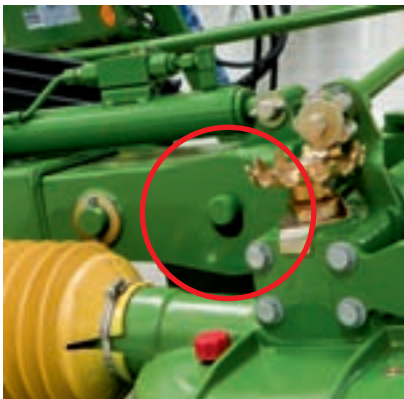

Cardanic suspension as standard! The plate with an elongated hole allowing a free pendulum in direction of travel. From this point, the tridem axles guide the cardanic linked rotors.

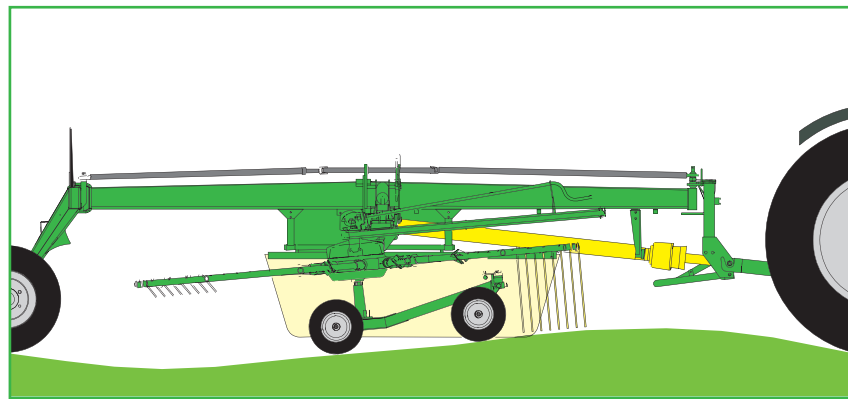

Contaminated forage is unacceptable: Cardanic suspension is perfect for the production of high quality forage. The cardanic suspension means that the rotors optimally follow all ground contours, even lengthwise in the driving direction and this ensures that the predetermined working height is better maintained especially when working in uneven ground. This will pay for itself in a very short time. The tines follow the ground contours, operate cleanly and endure less stress. The KRONE Swadros leave nothing behind on the ground, not even in hilly or undulating terrain.



At a glance

	Swadro 700	Swadro 800/26	Swadro 900
Mechanical work depth control	+	+	+
Mechanical work width control	—	+	+
Hydraulic work width control	—	option	option
Separate rotor lift/lower feature	—	+	+
Rigid tine arms	(+)	(+)	—
Folding tine arms	(+)	(+)	+

+ Base specification

(+) Required accessory

— not available



Optimized depth control – all Swadro 700, 800/26 and 900 rotors have cranks that allow setting their depth variably and conveniently. Accurate depth control is essential to achieve clean rakes without losses.



These will tackle any job: Over-dimensioned, single-acting hydraulic cylinders fold the rotors into the headland or transport position. Coil springs are used on Swadro 800/26 and 900 to reduce the ground pressure on the gauge wheels.



Straightforward system. One single-acting spool will do to operate a Swadro 700, 800/26 and 900. The Swadro 800/26 and 900 models have a valve that is operated from this handle to select one or both rotors.

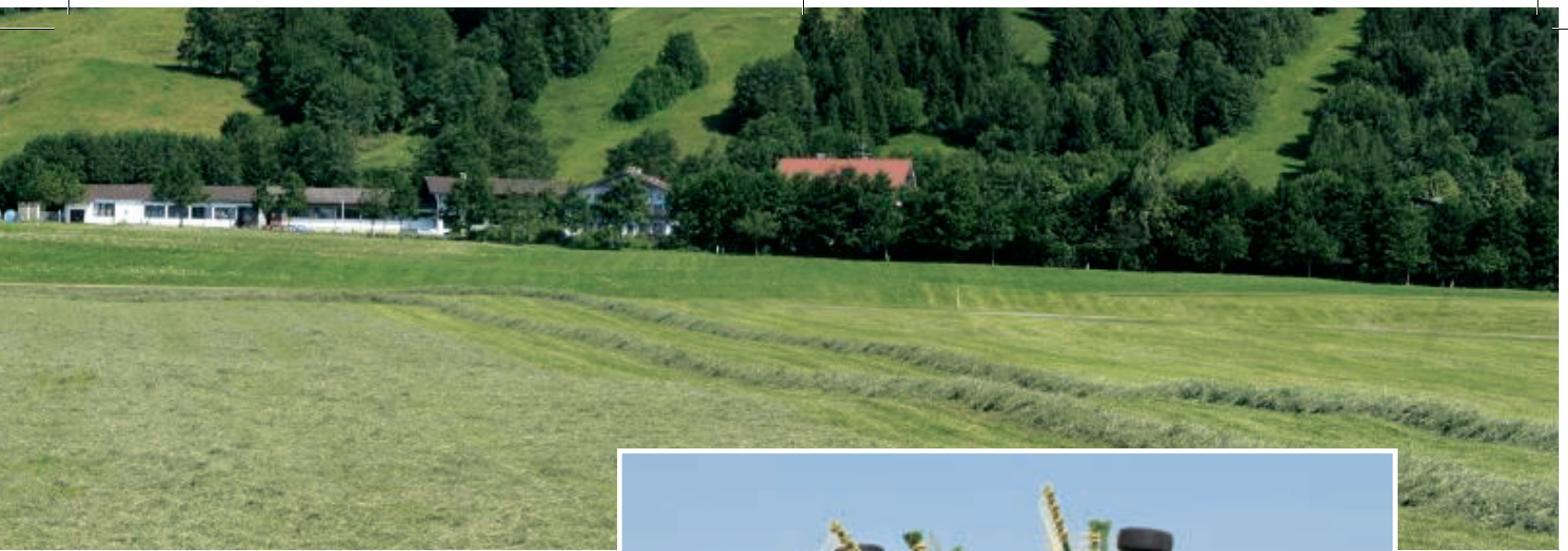

At 40 km/h (25 mph) you get the time- and money-saving transport running gears on the KRONE twin rotor rakes are approved to 40 km/hr (25 mph), a specification that pays off quickly in variable weather when you need to change fields quickly. Folding tine arms are available for the center-delivery models Swadro 700, 800/26, 900 and their respective 'Plus' versions, enabling even faster changes.



The wide track of the running gear and the large 10.0/75-15.3 8PR tires are well thought through with a maximum speed of 40 km/h (25 mph) in mind and provide the ideal safety at fast speeds.



Flexible work and windrow widths. Work width on Swadro 800/26 and 900 models is adjusted mechanically and the rotors move in/out as you operate a mechanical crank. A hydraulic work width control system is available as an option.

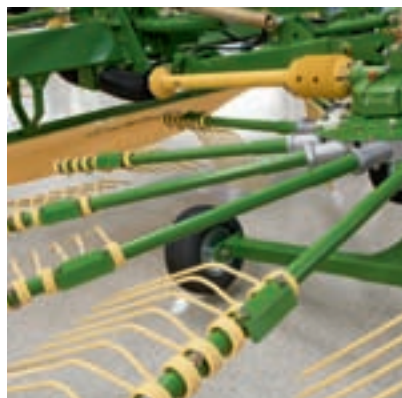

Rigid arms. All rotors on the Swadro 700 and 800/26 center-delivery models are also available with rigid tine arms – an intriguing option, if machine height is not an issue.



Wide in the field and low on the road – folding tine arms are always a safe bet in areas where road travel involves passing under low bridges and gateways. The arms fold quickly and easily.



Swadro 700 Plus, 800/26 Plus, 900 Plus

Ultimate level of comfort

- Electric work depth control 
- Convenient operation from the electric control box
- Manual work width control on Swadro 700 Plus
- Hydraulic work width control on Swadro 700 Plus, 800/26 Plus, 900 Plus
- Separate rotor lift/lower feature

'Plus' refers to one extra feature – high-level operator comfort – that is available on the center-delivery models Swadro 700 Plus, 800/26 Plus and 900 Plus. Providing ease of operation, these models tick every box, everything falling into place and bringing fun to field work.



Cab based control – electric servomotors control machine depth on the go, giving you a superior command of the machine and clean, loss-free rakes.



Convenient – the electric control box on Swadro 700 Plus, 800/26 Plus and 900 Plus serves two purposes: It controls the depth via electric motors and it preselects the left or right rotor for separate lift-out.

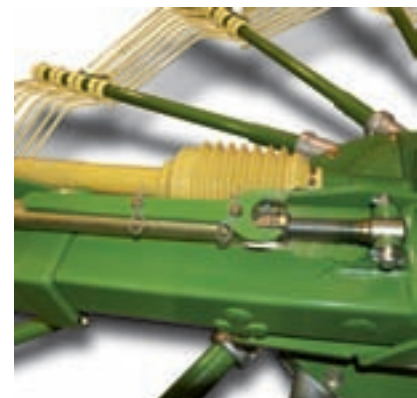

Manual – Swadro 700 Plus uses a crank on its telescopic arms to adjust the working width. The system allows you to select the desired working width and set the ideal windrow widths for the following harvester.



At a glance

	Swadro 700 Plus	Swadro 800/26 Plus	Swadro 900 Plus
Mechanical work depth control	+	+	+
Mechanical work width control	+	—	—
Hydraulic work width control	—	+	+
Separate rotor lift/lower feature	+	+	+
Rigid tine arms	(+)	(+)	—
Folding tine arms	(+)	(+)	+

+ Base specification

(+) Required accessory

— not available



Variable widths – Swadro 800/26 Plus and 900 Plus feature double-acting rams that adjust work and windrow widths infinitely variably and form windrows of ideal sizes for the following harvester, boosting harvester efficiency and cutting the overall costs of the harvest chain.



On the headland, the operator quickly raises the rotors from the tractor seat. The rotors lift out high, giving plenty of ground clearance to travel over massive windrows.

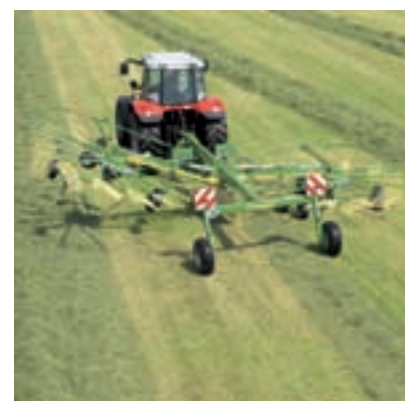

Using only one rotor? No problem! It's easy for Swadro. After all, this is often necessary in low yielding crops, awkward fields and when raking along boundaries.



Swadro 1000

The center delivery rake with 10 m (32'10") working width

- Variable 8.80 m - 10.00 m (28'11" - 32'10") working widths
- 15 tine arms per rotor
- 8 castoring wheels on wide bogies
- Electric height control
- Cardan rotor suspension
- Large transport wheels

Swadro 1000 is the KRONE centre delivery rake for high-output and high-acreage operations. Boasting two rotors with 15 tine arms each, it rakes up to 10 hectares (25 acres) per hour. The variable 8.80 m - 10.00 m (28'11" - 32'10") working width adjusts hydraulically via telescoping arms. The maintenance-free rotors with cardan suspension and the ground hugging bogies with eight castoring wheels combine with a superb operational comfort to make this center delivery rake a flexible and high-output machine.



High output, superior comfort and ultimate stability – thanks to the maintenance-free rotors, each equipped with 15 tine arms, the Dura-Max cam track, large guide rollers in permanently lubricated bearings and widely spaced deep groove ball bearings in the Aluminium tine holder housings.

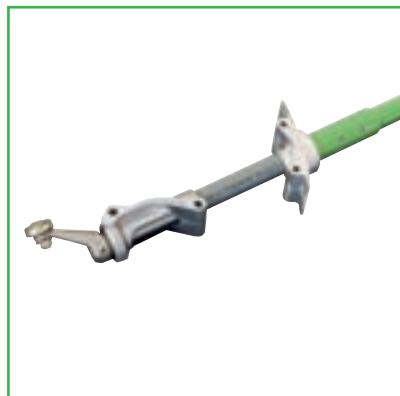

Straightforward and simple: The operator removes just four bolts and then pulls the tine arm from the rotor together with its bearings and guide roller. To replace the outer arm end, he simply removes two hollow pins.



Height control on the move: Operators adjust the work height fast, steplessly and accurately from the control unit and via electric motors, a convenient system that offers ultimate flexibility in varying conditions.

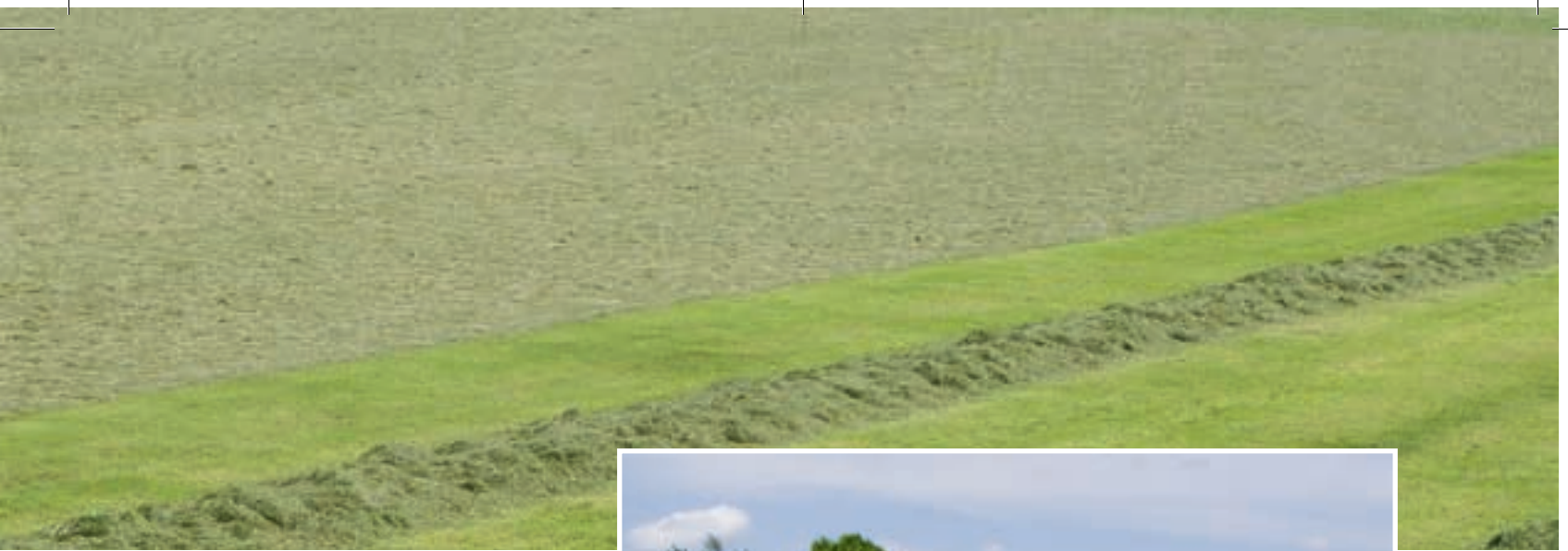

Swadro is KRONE's response to market demands for a center delivery rake with two rotors and wide working widths. Thanks to their special build and straightforward design, the rotors offer easy operation and high work rates as they rake the crop to uniform windrows. Boasting 15 tine arms on each rotor and 4 double tines on each arm, Swadro 1000 achieves highest area outputs and perfect windrows that maximize the efficiency of the following harvester. Slightly tilted to the side, it allows precise adjustment for cleanest work. Separate rotor lift/lower control is standard.



No crop loss: The tandem-axle bogies on Swadro 1000 run on eight wheels for optimum ground hugging and cleanest rakes. The freely swivelling wheels provide positive tracking even in the tightest bends.



A serious machine: The trapezoidal main frame is strong and durable. The tine arms fold up to a transport height of less than 4 metres (13'1") and the transport chassis is approved for 40 km/hr (25 mph) for swift travel from one field to the next.



Excellent tracking: The machine features forced steering for superior tracking around bends. The system consists of a tie rod, which is attached to the two-point headstock and safely steers the wide-tracking chassis on large 15.0/55-17/10 PR tires around the tightest bends.



SWADRO 710/26 T

The variable Side Delivery Rakes

- Single and double windrows
- Rakes to the right
- Variable working width
- Cardanic suspension of rotors
- Hydraulic swath curtain adjustment
- 13 tine arms per rotor for Swadro 710/26 T



The KRONE 710/26 T twin-rotor side delivery rake with 13 tine arms not only offers excellent value for money but excellent quality of work. Swadro 710/26 T forms single and double windrows as well as two narrow windrows. Naturally it offers a hydraulic system that adjusts the main frame to set the work width and thus windrow width.



For a safe connection to the pick-up hitch or to the tractor's trailer eye: the drawbar can be adjusted in height with the hitch being controlled via a parallelogram linkage. The hydraulic cylinder on the hitch keeps the front rotor level during mounting and lifting.



With tandem axle: a broad layout with 18" tires for optimum contour following. For the best possible slope stability, the front tires are each positioned in the farthest outer position. Adjustment of the working height is carried out via adjustable supports that are positioned with pins up a series of holes.



Adjusting rotor tilt: clean forage movement without loss must be ensured even in the heaviest of forage. The transverse slope of the rotor can easily be adjusted via a spindle so that each rotor works cleanly because as the crop is transferred in the direction of the swath curtain the tines have to move more mass.



Single raking

i
 One 6.20 m (20'4") windrow
 Two 3.40 m (11'2") windrows
 A double windrow of 12.40 m (40'8")
 Three functions –
 Versatile application



Twin raking



Double raking



In position for single windrowing towards the right: ideal for harvesting machinery with large intake capacity and in light yielding crops.



Rear rotor over to the left – rear rotor over to the right: this is done quickly and easily with the hydraulic pivoting cylinder from the tractor seat. The working width during single windrowing can also be varied via this cylinder.



Over to the left and in position for twin windrowing: ideal for harvesting machinery with a low intake capacity, for voluminous forage with a large mass, or for overnight raking.

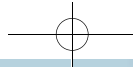

Approved for 40 km/h (25 mph): a quick transfer and therefore low transport times is the essential criteria that increases machinery work-rates. The wide tracked tandem axles with 18" tires provide the ideal travelling behavior at high driving speeds.



Ingenious solution: A cardanic linkage of the front rotor via a float position on the hydraulic cylinder integrated in the drawbar and for the rear rotor via an elongated hole on the rotor suspension. The impressive result: a large pendulum travel for the best rotor following.

The cardanic rotor suspension: this is raking technology at its finest. The cardanic suspension of the rotors ensures that the rotors always optimally follow the ground conditions, both side to side and front to back. The KRONE Swadros pick up all the crop in a clean and tidy manner every time, whether in hilly or rolling terrain leaving nothing behind.

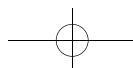



Reasons for choosing Swadro 710 T with 26 tine arms: It is versatile. The working width is variable for single windrowing. Furthermore, two individual, small windrows may be left during one operation, which is ideal for tidying up at night, or for following harvesting machinery with a low output capacity. Experts report that the 710T makes possible, extremely accurate front to back raking. Also lauded are the compact transport dimensions, the easy assembly and disassembly, but also the lack of any need to convert from work to the transport position.



Perfect – raking to the right: since the operating controls are also grouped on the right side of the tractor cab, these rakes provide the highest degree of driver comfort.



Front support wheels for perfect rotor guidance in combination with the cardanic linkage: they are trailing, adjustable in height and additionally, depending on the amount of forage, can be moved sideways if necessary.



It holds up: the main frame with its box-section profile is robustly designed to withstand huge stresses. This provides a safety margin when driving at high speeds on poor quality roads and while working under difficult conditions.



Comfortable: the hydraulic swath curtain adjustment for the rear rotor. The adjustment for differing windrow widths is done from the tractor seat. For road transport, the curtain is retracted hydraulically.



Swadro 807, Swadro 810

The twin rotor Side Delivery Rakes

- Swadro 810: single and twin windrowing
- Cardanic rotor linkage
- Wide gauge running gear with steered rear axle
- The front and rear rotors are sequence controlled



The models Swadro 807 and 809 are engineered to rake the crop into one massive windrow on either side of the tractor. The Swadro 810 additionally provides the additional opportunity of laying two small windrows in one pass. If the two large single windrows are laid side by side from two passes to and fro, a total working width of up to 14,00 m (45'11") can be achieved depending on the windrow size. In this manner, enough forage can be combined together to maximize the performance of any subsequent harvesting operation to their fullest, even in third and fourth cuts.



Variably adjusting the working height: As standard equipment, a spindle quickly and comfortably adjusts the working height of each rotor thus ensuring the best raking effect under any condition.



The electronic control box with electrical actuators for the adjustment of the working height is available as an option for the Swadro 810. The box fulfils two functions: the in-cab adjustment of the working height and the pre-selection of the individual left or right hand rotor lift.



On-the-move working height adjustment: the Swadro 810, when equipped with the optional actuators makes the adjustment of the working height sensitive and precise. The system is weatherproof and can be operated while travelling.



Swadro 807 forms windrows from 6.20 metres (20'4"), Swadro 809 and 810 from 6.80 metres (22'4"), placing them to side. The car danic rotors complete with tridem axle follow any ground contour. The result: the cleanest raking quality without loss.



The twin windrowing of two times 3.70 m (12'2") with the Swadro 810 for: ideal for following machinery with a low harvesting capacity, or for bringing grass together at night.



From a single to a twin windrow: no problem for the Swadro 810. If necessary, the inner rotor can be telescoped out from the tractor seat so that sufficient room is provided for the second windrow to be laid.

Fully equipped: two swath curtains on the Swadro 810. Single windrowing is done with the outer one, twinwindrowing is done utilizing both. If the inner swath curtain is not needed it can simply be folded up out of the way.

Always the right size: the swath curtain can be telescopically adjusted for width. For height this is done quickly and easily via spacers. Multiple adjustment possibilities guarantee a perfect windrow shape under all circumstances.



Down the road at 40 km/h (25 mph), compact and safe: when on public roads and driving underneath low bridges and underpasses, utility lines and masts the upper, outer tine arms can be folded in.



Agile through and through: the Swadro 807, 809 and 810 rake up everything due to their high maneuverability, even in restricted areas. With a wide wheel track on the running gear and a steering axle, they can master any corner.



Optimally equipped: the large 10.0/75-15.3 8 PR tires and track-following linkage ensure absolutely smooth and stable travelling – an advantage when working on slopes or at high driving speeds.

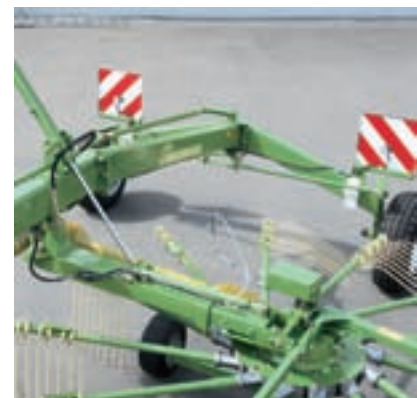

They do deliver: over-dimensioned, single-acting hydraulic cylinders lift the rotor comfortably into the headland or transport position.



The Swadro 807, 809 and 810 side delivery rakes have been tested and proven for the use with forage harvesters. Night raking is also possible with the Swadro 810 dual-function rake. Thanks to their rear axle steering, they are highly flexible, have excellent tracking behavior and can master any twist and turn. The well-dimensioned wide tracked running gear ensures complete stability on slopes. These rakes can be easily maneuvered, running absolutely smoothly on the road, even at 40 km/h (25 mph). For clean work at the headland these rakes, like all tandem axle Swadro models have, of course, also been equipped with the KRONE Jet Effect.

Depending on the desired windrow width, the working width when driving to and fro is up to 15.00 m (49'3"). This results in a large enough windrow to satisfy even the most high capacity of harvesters, even in the 3rd and 4th cut.



Ground clearance galore: The placement of the main rotor drives next to the support frame enables a quicker and higher lifting of the double tines above the ground. This provides more clearance when driving over already formed windrows.



Rotors connected in series: during lifting and lowering, the front rotor is always placed into headland or working position first followed by the rear. The length of time taken to drop during the lowering operation is adjustable.



Manufactured for high demands: the box-section frames of the Swadro 807, 809 and 810 slope to be higher in the center. In this way there is even more ground clearance when driving over already raked windrows.



Swadro 907

Raking 8 metres (26'3") of crop into one windrow

- 8.00 m (26'3") work width for highest work rates
- 15 tine arms per rotor
- Wide bogies with 6 wheels each
- Cardan rotor suspension system
- Hydraulic crop deflector
- Overrunning clutch protected rotor drives



Swadro 907 is the KRONE twin-rotor side delivery rake with 8.00 m (26'3") work width. Running on a wide-tracking axle and boasting 15 tine arms and 6 wheels on each rotor, this rake delivers cleanest rakes and highest workrates.

Maintenance-free rotors, the Dura-Max cam track, large guide rollers in permanently lubricated bearings and widely spaced deep groove ball bearings in Aluminium tine holder housings combine to give an outstanding operator comfort, highest workrates and ultimate durability.

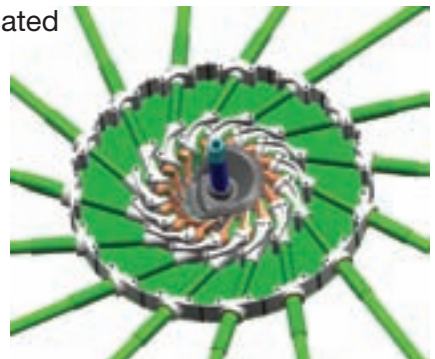

Perfect, also in heavy crops: Each of the large and sealed rotors runs on six castering wheels. An optional electric depth control and pin/hole tilt setting system ensure cleanest rakes and highest productivity.

Direct and frictional: All gearboxes and shafts mount outside the beams for easy access. The rotors are protected by star ratchets and the drivelines by standard overrunning clutches.

Adjustable coil springs for rotor suspension: They shift much of the jib and rotor weight to the main frame to ensure positive tracking on the slope as well as light and soft running.



The KRONE Swadro 907 is a high-end side delivery rake. Boasting an area output of 8 ha/h (20 acres/h) and 16.00 m (52'6") work widths, this machine gives you the edge in foraging. The leading rotor operates at a higher circumferential speed than the rear unit to the end of forming the most uniform and fluffy windrows. The job gives the lifted rotors a high ground clearance, an important detail when running on raked crop. The rear rotor lifts out with delay to the leading rotor to provide a uniform windrow at the end of a pass. This model features cardan suspension for the rotors, too. The special KRONE Jet Effect translates into clean forage and an undamaged headland



From the tractor seat: The left rotor features a hydraulic crop deflector setting system, which moves the deflector into a low transport position and adjusts it to different crops and yields.



Low transport height for safe travelling on public roads: The outer tine arms on Swadro 907 fold up fast and easily. With tines in their fold-up position, the rake passes easily under bridges and passageways.



Excellent tracking: Thanks to double-pivot steering, Swadro 907 gives positive tracking behind the tractor in any bend. The robust and wide-tracking chassis runs on large 15.0/55-17/10 PR tires for quiet running and is approved for 40 km/h (25 mph) road speeds.



Swadro 1010

The Side Delivery Rake with three rotors

- High output with 9.70 m (31'10") working width 
- Working height adjustment via electric actuators
- Transport running gear with high driving comfort
- Cardanic rotor suspension for the best ground alignment
- KRONE-Jet-Effekt

A double windrow of nearly 20.00 metres (65'7") – these are ideal windrow conditions for a high-performance forage harvester. The KRONE Swadro 1010 three-rotor side windrow rake takes this task on completely and convinces with a potential work-rate of up to 10 hectares (24 acres) per hour making the crop chain even more efficient. Thanks to the wide tracked running gear with steering axle, this large-scale rake is extremely agile and is very easy to maneuver.



Contaminated forage? No thank you! Changing application conditions often require immediate adjustment of the working height. This can be done while driving via the weatherproof electric actuators, which can be adjusted by the driver via an electronic control box.

Guidance at its best: the combination of tridem running gear and cardanic rotor suspension ensure clean raking, also on uneven ground. The following front wheels, connected via a track rod, follow round even the tightest of curves.

A rear axle that steers: for an optimal tracking behaviour and excellent agility. The over-sized running gear with large 15.0/55-17/10 10 PR implement tires stands for safety and is gentle on the turf.



With rotors that are perfectly aligned with each other: in order to create a clean side windrow, on a working width of 9.70 m (31'10"), everything must be right. For this reason the Swadro 1010 has different rotor diameters with different speeds. The front rotor is equipped with 10, yet the center and rear rotors are each equipped with 13 tine arms. The front and center rotors have higher peripheral speeds and this results in a better flow of forage. The slowly rotating rear rotor is equipped with 5 double tines per arm because it must move more volume of grass and is responsible for the shape of the windrow.



Reaching the destination at 40 km/h (25 mph), and with a transport width of below 3.00 m (9'10"): the three rotors can quickly be brought into transport position. Since the rotor diameter of the center rotor is below 3.00 m (9'10"), the tine arms on the center rotor do not need to be folded in.

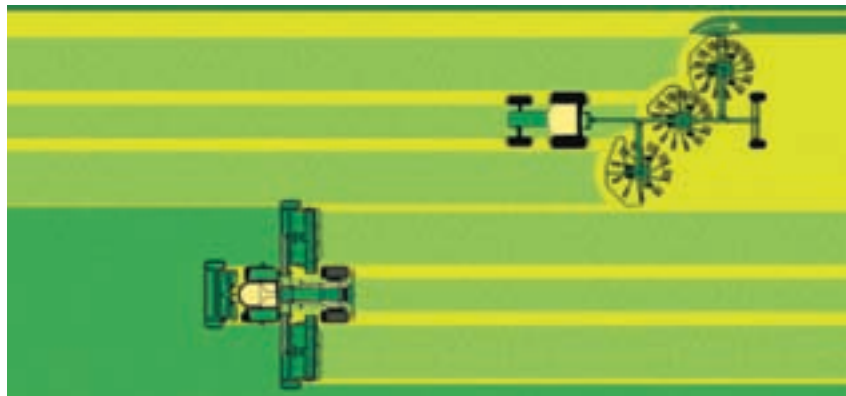

In perfect alignment with each other with a matched working width of 9.70 m (31'10"): no forage is run into the ground as the tractor pulling the Swadro 1010 runs nicely in the wheel tracks of the KRONE BiG M high-performance mower-conditioner.



Swadro 1400

Four-fold power

- Variable working width up to 13.50 m (44'4")
- Alpha, Gamma and CCI – three options for high operator comfort
- Electric depth control from the tractor seat
- Folding tine arms bring transport height down to less than 4.00 m (13'2")
- Separate rotor lift/lower feature

The four-rotor center delivery rakes from KRONE are productive workhorses. With the Swadro 1400 and an adjustable working width of between 11.00 and 13.50 m (36'1" and 44'4"), one can easily handle more than 13 hectares (32 acres) per hour with just one tractor. This giant performance enables the replacement of two twin rotor rakes with merely one Swadro 1400.



Robust and well thought out: the lower link mounted headstock has pendulum suspension adjusting ideally to all lateral tractor movements. If the tractor's lower links arms are lifted inadvertently the PTO shaft cannot be damaged.



Optional specification: The drawbar on Swadro 1400 features a ball hitch and hydraulic height adjustment. Tractor attachment and removal is easy. No link arms required. No jolting. All operation is safe and absolutely comfortable.



High load-bearing: in conditions of higher than usual operational stresses are not always ideal. For this reason the Swadro 1400 has a very robust frame, thereby completely meeting the high requirements found in practice.



The even, well formed center window left by the Swadro 1400 ensures an even better efficiency of any following harvesting machinery with contractors talking about an increase in intake capacity of the forage harvesters by more than 20 %. Swadro 1400 boasts plenty of innovations, such as cardanic rotor attachment, the KRONE Jet effect, the extra hard Dura-Max cam track with 3-year warranty and electric servomotors for depth control.



The windrow is magnificent: with the Swadro 1400, the peripheral speed of the front rotor is higher than that of the rear rotor and this optimal matching of two rotor speeds is a KRONE innovation, the result of which is a perfectly even, box-shaped, loosely made windrow.



For professional use: with 13 tine arms per rotor, four double tines per arm, ground-covering tridem axles and the cardanic rotor linkage ensure an optimal ground alignment in all directions.



Spring compensation: tension springs displace a large part of the weight of the front telescopic arms and rotors back onto the main frame. This prevents the rotors from sinking in on moist ground and ensures that the rake follows in the tractor tracks in hillside situations.



Clearance galore: the linkage of the suspension arms coupled with the horizontal position of the main frame enable additional lifting power and thanks to a sequenced actuation the front rotors are always lifted or lowered first.



Wide in the field and narrow on the road – enjoy the sense of safety that comes from the air brake system on the 40 km/h (25 mph), wide-base running gear, from the large tires and a less than 3 m (9'10") transport width. Folding tine arms and a chassis that inclines toward the tractor combine to bring Swadro 1400's transport height down to less than 4.00 m (13'2"), helping you comply with regulations and providing safe passage under bridges, gateways, overhead lines and tree branches.



Premium-level electronic control – the ISOBUS compatible board computer allows operators to use their preferred KRONE operator terminal – Alpha (only for Swadro 1400), Gamma or CCI – or an ISOBUS compatible tractor terminal.



The Alpha terminal for Swadro 1400 is used to control work depth and width as well as the width of the windrow. Simply press a button to raise and lower one rotor or both rotors sequentially. Swadro 1400 is compatible with the tractor's load sensing system.



The Gamma terminal with a backlit digital display screen provides an excellent overview of all machine functions and allows Swadro 1400 Plus operators to have all rotors automatically adjusted to a programmed height.

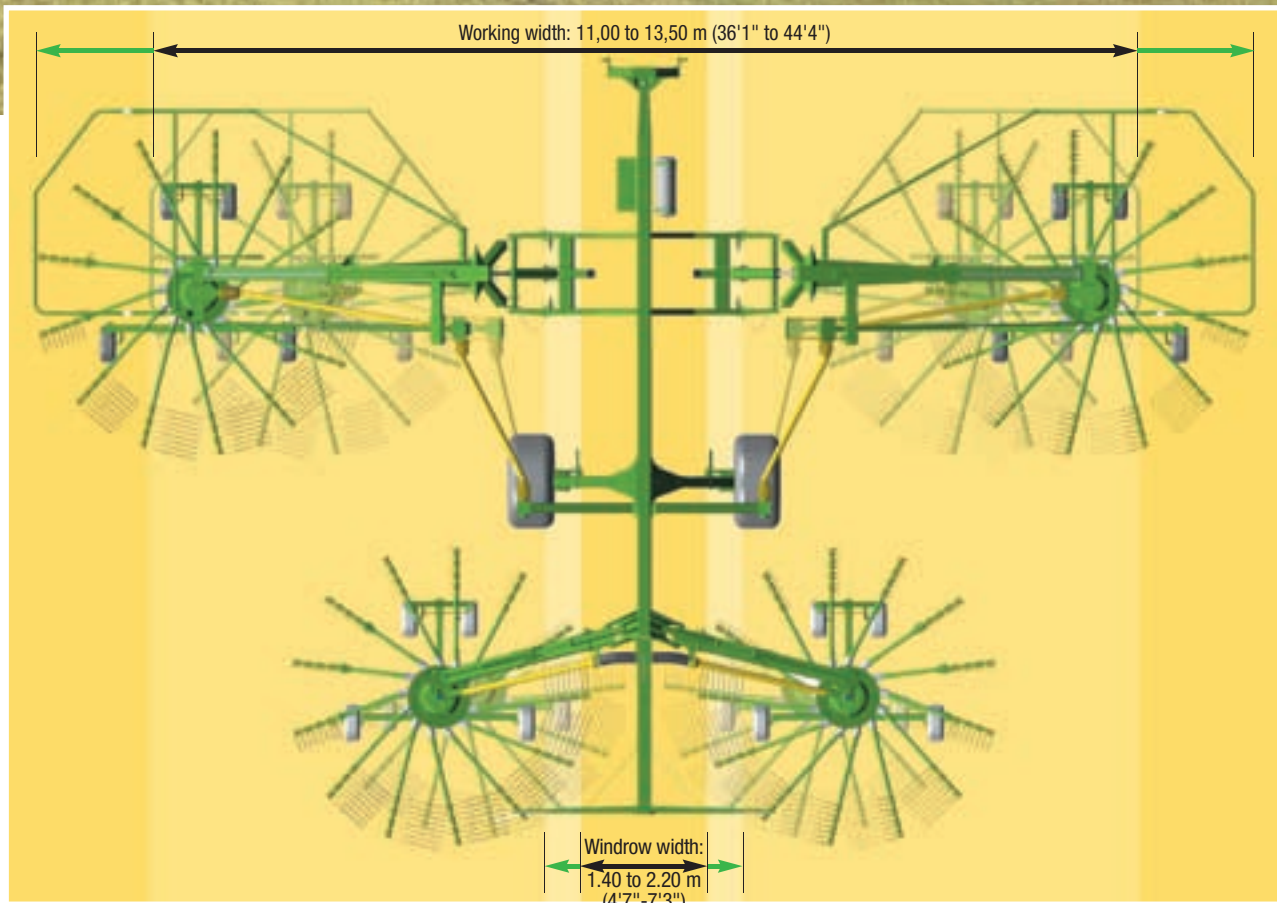
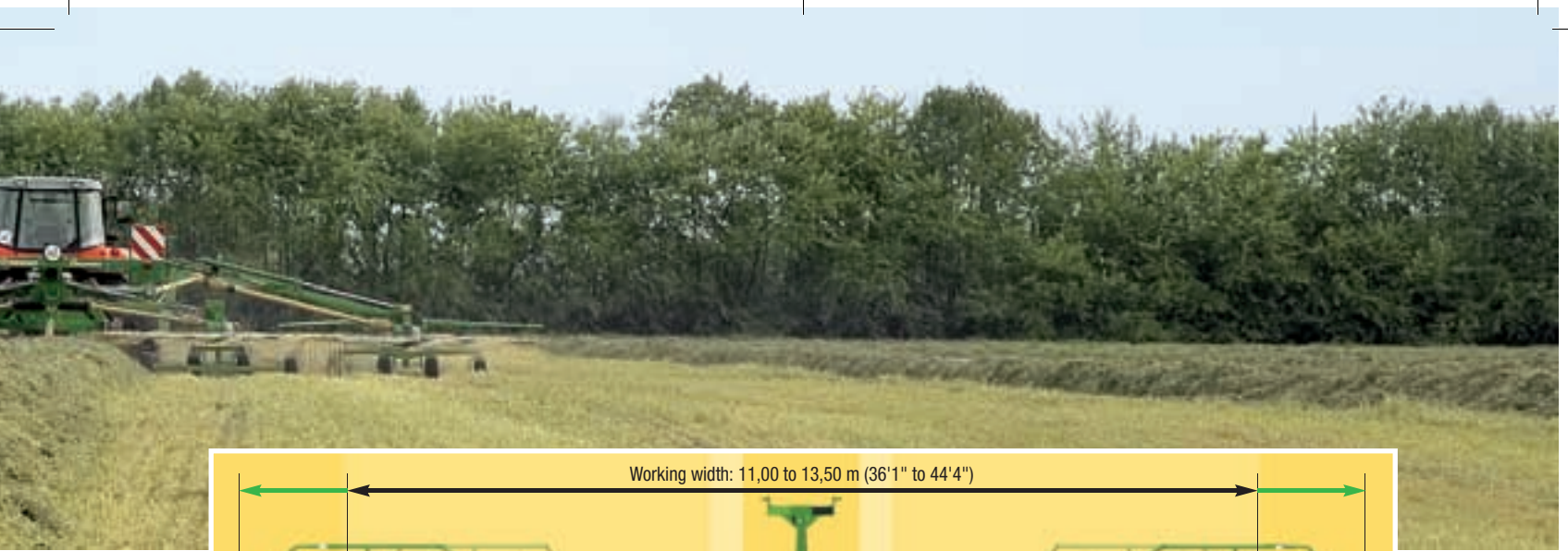

Terminal CCI 100: CCI-ISOBUS is one control box for all. This terminal comprises not only all Alpha and Gamma functions but provides universal control on the ISOBUS machines from a large number of manufacturers.

11 m - 13.5 m (36'1" to 44'4") work widths: The system gives you the flexibility you need to operate in varying conditions and to different requirements. You can vary windrow widths from about 1.40 m to 2.20 m (4'7" - 7'3") by adjusting the rear rotors. The working width of the front and rear rotors is set hydraulically via telescoping arms. As these also reposition the right-angle gearboxes that drive the front rotors via driveshafts, the system ensures optimum overlapping of the telescoping arms.



Swadro 1400 Plus

Ultimate performance

- Transport running gear lowers hydraulically to a transport height of less than 4.00 m (13'2")
No folding tine arms
- Automatic depth control after setting the depth on the first rotor
- Heavy-duty driveline for constant operation in demanding applications
- Superior operator comfort from the Gamma or CCI 100 operator terminals



The plus about Swadro 1400 Plus is its superior operator comfort and top performance in really tough conditions. The comprehensive base specification level includes the hydraulically lowering running gear, electric Comfort height control and extra strong driveshafts, ticking every box.



The swath deflector in the middle is an option. It helps forming perfect windrows, also when raking with one rotor raised out of work. The deflector curtain folds automatically into transport position to provide good ground clearance.



Electric Comfort rotor height control. Select from the cab the depth for the first rotor. After that, the servomotors set the remaining rotors automatically to identical depths.



Powerful driveline – the gearboxes mount far out on the wings for driveshafts to run smoothly. Swadro 1400 Plus features heavy-duty driveshafts and the rotors are star ratchet protected.

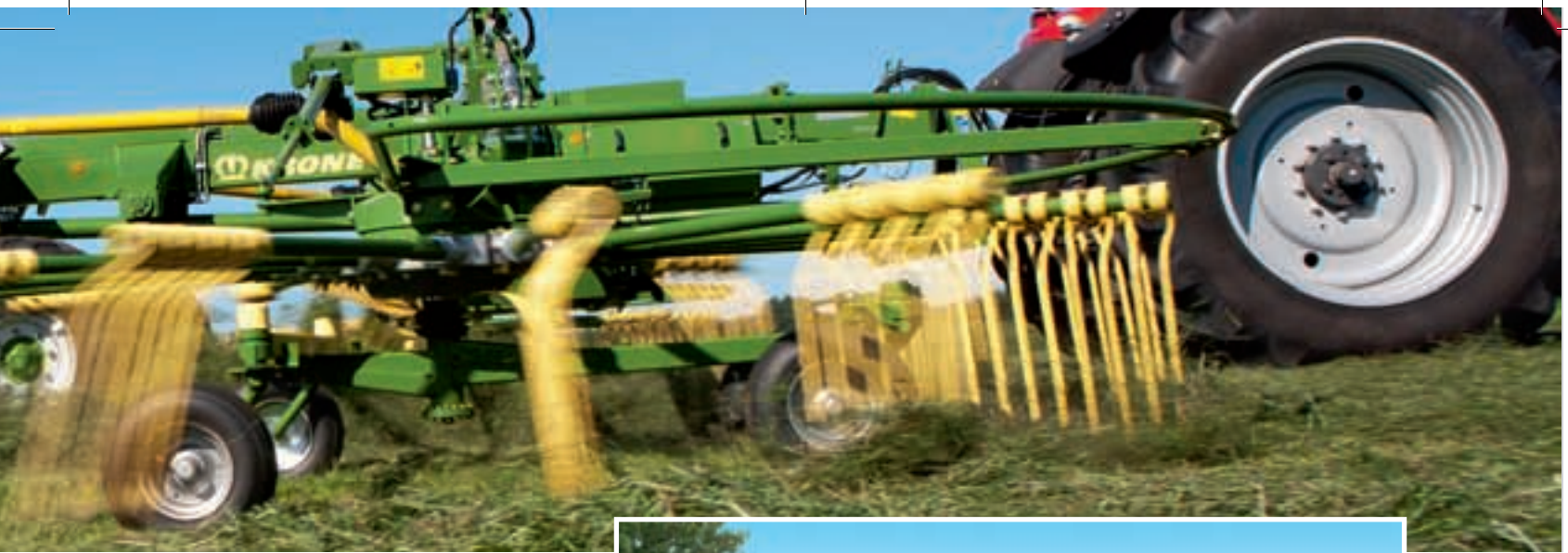

Machine viability is vital for contracting businesses. Viability refers to high area outputs, quick conversion, low maintenance, fast road transports, long machine lifetime cycles and of course high operator comfort. The four-rotor center-delivery rake Swadro 1400 Plus was designed for contractors. This machine is fully controlled from the tractor seat to get you to the next field quickly and deliver!

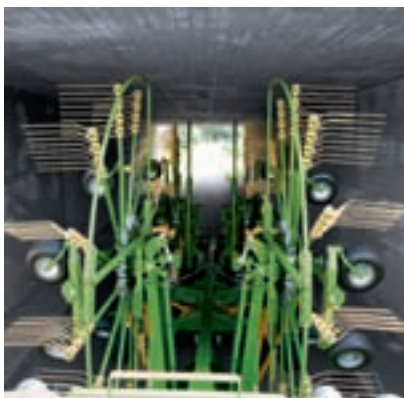

Move the rotors in transport position from the tractor seat. The hydraulic height control system lowers the axle to a less than 4.00 m (13'2") transport height, so that Swadro 1400 Plus has no requirement for folding the tine arms. The tine arms are rigid on this model.



Lowering the transport height to less than 4.00 m (13'2"), the hydraulic axle quickly converts Swadro 1400 for road travel, saving time and boosting operator comfort.



Choose between standard 500/50-17/10 PR tires and bigger 560/45-22.5 tires, which have proven its worth on the transport chassis running in hilly terrain. Both versions are approved for 40 km/hr (25 mph).



Swadro 2000

The champion among the center-delivery rakes

- Variable 10 m-19 m (32'10" - 62'4") work widths
- Variable 1.6 m-2.8 m (5'3" - 9'2") windrow widths
- Cleanest rakes from 6 maintenance-free and small 330 mm (1') rotors
- Synchronized width control via sliding carriages
- Height control via electric servomotors



Swadro 2000 features 6 rotors that work at a width of 19.00 m (62'4"). This working width gives you the potential to rake up to 20 ha (49 acres) per hour. This enormous efficiency combines with a uniform quality of work and fluffy windrows – thanks to the leading rotors spinning faster than the units at the rear. These windrows are ideal for hungry harvesters. Swadro 2000 boasts plenty of innovations, such as cardanic rotor attachment for excellent adaptation to ground contours and especially hardened Dura-Max cam tracks with 3-year warranty. Attaching / removing the tine arms is quick and easy. The arms are fully specified with bearings and guide rollers. Simply remove two or four bolts and pull out the arm. It's as easy as that.



A unique KRONE design – the four leading rotors feature 13 tine arms that spin at higher speeds than the following rotors, each boasting 15 tine arms. It is this difference in rotor speed (3,300 mm (10'10") rotor diameters) that leads to cleanest rakes and fluffy windrows.



Perfect control. The tridem axles account for clean forage, because the wheels run closely behind the inner tines and provide optimum ground following. The castoring wheels follow every bend and protect the turf.



Convenient – electric motors adjust the working depth, either on each rotor separately or automatically one after the other. The function is carried out from the tractor seat for quick adaptation to current conditions.

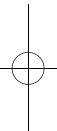
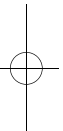

Powerful driveline, low input requirement, tidy design – the rotors are driven by the central gearbox, the position of which reduces the number and length of the driveshafts required. Each rotor features its own separate overload protection.



Flexible work widths: The current working width is varied hydraulically by the swinging arms to match window widths to the capacity of the following harvester. The action of two swinging arms is synchronized by the sliding carriage.



Hydraulic window width control allows operators to telescope the two rear rotors in or out to vary the distance between them and match windrow widths to the capacity of the following harvester and boost efficiency and profitability.

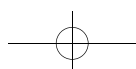



Gigantic in work – compact in transport

- Synchronized changeover from the cab
- No removal of tine arms
- Less than 3 m (9'10") transport width
- Less than 4 m (13'2") transport height



Working at widths of up to 19.00 m (62'4") and folding into a narrow transport width of 3.00 m (9'10"), Swadro 2000 is an impressive performer both in the field and on the road.

Featuring six rotors, this machine is a new symbol of efficiency. Swadro 2000 caters for a wide range of applications including large-scale farms and contract work, which involves frequent travelling between sites and therefore frequent changeovers. For that reason, Swadro 2000 features tine arms that do not require folding. In addition, it provides for in-cab control of the entire changeover process.



Perfect support: The swinging arms run on unsteered 15.0/55-17/10 wheels, which mount on the ends of the arms and swing up for transport. The arms swing in to rest on the main beam and lock into position.



Anything is possible. Swadro 2000 offers a range of optional functions: lift/lower only one rotor or one after the other or all rotors at the same time. Sequence control functions make headland turns a piece of cake. All rotors swing up 90° into transport position.



In 'sync' – the swinging arms are linked to the main beam via hydraulic carriages. The system not only adjusts the working width but also swings the rotors in transport and work position.



Easy going

One-touch control changes into transport position:

Swadro 2000 also stands out for easy handling and functionality during changeovers, where automatic sequence control and the high operator comfort reduce operator fatigue and lead to higher daily outputs.



How you do it:

First, lift the rotors to headland position. Then retract the two rear rotor arms at the rear. At the same time, the two leading beams with the front and central rotors swing in as well. All action is synchronized by the sliding carriage on the main beam, an ideal system for slope operation. Extra guidance and stability comes from the unsteered wheels on the ends of the arms. The wheels swing up for the swinging arms to rest on them along the side of the main beam. As a last step, the rotors fold into vertical position and the machine is ready for safe and compact road travel.





Swadro 2000

Technology of ultimate perfection

- Easy steering Easy operation Sequence control and Comfort height control
- Separate rotor lift/lower
- Steered axle with active and passive function
- Uniform windrow presentation



Swadro 2000 not only impresses by its tremendous working width but also by its ease of handling and great maneuverability. It is equipped with a pivot steer axle that travels around any bend. This agility is required for contract work in small fields. The transport chassis is approved to 40 km/hr (25 mph) and features large flotation tires to minimize ground pressure and effectively protect the windrow.



Robust by design, Swadro 2000 hitches to the tractor's link arm. The flexible cat II/III headstock compensates for any humps and bumps while the strong stand provides uncompromised stability. Holders are provided for tidy storage of driveshaft and supply lines.



Innovative steering: The steering linkage moves hydraulically to the side to enable steering. The hydraulic ram is activated as the rotors lift and lower. It extends to activate steering and retracts to inactivate steering.



Maneuvering and working in awkward patches is made easy thanks to the hydraulic auxiliary steering system that is integrated in the steering linkage and which allows the operator to actively steer the transport running gear from the tractor seat. This increases the steering angle even further for even tighter turns.



In response to user demands, KRONE developed its genuine double-pivot steering axle, which offers ultimate comfort when travelling between fields. The axle is passive when the machine is raking to ensure uniform and straight windrow formation. As the rotors lift out of work, the steering axle is activated automatically to give the rake best tracking in tight headland turns and road bends. This auxiliary steering system allows the operator to steer the axle from the tractor seat when passing through narrow gates or when raking up awkward patches. This innovative system boosts efficiency in small fields and increases your work rates.



Double-pivot steering on the transport running gear allows for wide steering angles and therefore excellent tracking. It makes the combination very nimble and also offers high stability on the slope.



Comfort height control: The electric control unit has a digital display screen, where the operator sets working and windrow widths and all rotors to a preset level.



The easy-to-use control unit operates all major functions – work width, rotor lift/lower via customizable sequence control and operates the individual rotors.



Technical Data

Three-point linkage single-rotor rakes

Model		Swadro 35	Swadro 38	Swadro 42	Swadro 46
Work width	mm (inch)	3,500 (11'6")	3,800 (12'6")	4,200	4,600
Area output	approx. ha/h (acres/h)	3 (7.4)	3.5-4 (8.6-9.8)	4-4.5 (9.8-11)	4.5-5 (11-12.3)
Transport width	mm (inch)	1,900 (6'3")	1,900 (6'3")	2,265 (7'5")	2,550 (8'4")
No. of tine arms		10	10	13	13
No. of double tines		30	40	52	52
Rotor diameter	mm (inch)	2,700 (8'10")	2,960 (9'9")	3,300 (10'10")	3,600 (11'10")
Tire size on bogie		16x6.50-8	16x6.50-8	16x6.50-8	16x6.50-8
Power requirement	approx. kW/hp	22/31	22/31	37/50	37/50
Weight	approx. kg (lbs)	532 (1,173)	569 (1,254)	640 (1,411)	665 (1,466)
Three-point hitch		Standard	Standard	Standard	Standard
Storage length	mm (inch)	3,120 (10'3")	3,390 (11'2")	3,690 (12'1")	3,990 (13'1")
Storage height	mm (inch)	2,210 (7'3")	2,210 (7'3")	2,490 (8'2")	2,640 (8'8")



Overrunning clutch: The Swadro 35, 38, 42 and 46 models can be specified with an optional overrunning clutch for the driveshaft, which is ideal on tractors with pto brake. The clutch protects tractor and machine when shutting off the pto.



An anti-tine-loss system is available for all KRONE rotor rakes. The system traps the tine when it breaks, so that it is not lost in the windrow, where it will cause further damage in the following harvester.



Trailed single-rotor rakes

Model		Swadro 38 T	Swadro 42 T	Swadro 46 T
Work width	mm (inch)	3.800 (12'6")	4.200 (13'9")	4.600 (15'1")
Area output	approx. ha/h (acres/hr)	3,5-4 (8.6-9.8)	4-4,5 (9.8-11)	4,5-5 (11-12.3)
Transport width	mm (inch)	2.995 (9'10")	3.400 (11'2")	2.550 (8'4")
No. of tine arms		10	13	13
No. of double tines		40	52	52
Rotor diameter	mm (inch)	2.960 (9'9")	3.300 (10'10")	3.600 (11'10")
Tires		18/8.5-8/6 PR	18/8.5-8/6 PR	18/8.5-8/6 PR
Power requirement	approx. kW/hp	19/25	21/31	21/31
Weight	approx. kg (lbs)	730 (1,609)	780 (1,720)	820 (1,808)
Drawbar		Standard	Standard	Standard
Storage length	mm (inch)	4.800 (15'9")	4.950 (16'3")	5.100 (16'9")
Storage height	mm (inch)	1.250 (4'1")	1.250 (4'1")	2.200 (7'3")

Swadro 38 T and 42 T are marketed in export markets only



KRONE is serious about aftersales service, because every operator has at least once seen his harvest chain grind down to a halt because of a downed machine – clearly an experience we all can do without. However, when this does happen then every minute counts. KRONE is aware of that and operates a dense network of professional dealerships, which operate well-stocked warehouses near your operation. Striving for ultimate efficiency, we are here to help you. KRONE – hay and forage technology.

Approved quality pays off, and therefore Original parts are less costly. Haven't you been through the experience at least once when your local dealer claimed a part was high-quality and then it did not work? Tests conducted by agricultural magazines have shown that manufacturer-tested quality parts last longer and operate more reliably. Do not compromise on quality and trust in Original KRONE parts.



Technical Data

Trailed side-delivery rakes

Model		Swadro 710/26 T	Swadro 807
Work width single raking	mm (inch)	6,200 (20'4")	6,200 (20'4")
double raking		2 x 3,400 (2 x 11'2")	-
No. of rotors		2	2
Area output	Approx. ha/h	5.5-6 (13.5-14.8)	6 (14.8)
Transport width	mm (inch)	2,995 (9'10")	2,990 (9'9.7")
No. of tine arms		26	23
No. of double tines		91	96
Rotor diameter	mm (inch)	2,960 (9'9")	2,960 (9'9")
Work depth control			
mechanical		+	+
electric			
Tire size on bogies		18/8.5x8/6	16x6.50-8
Tire size on running gear		18/8.5x8/6	10.0/75-15.3/8 PR
Power requirement	Approx. kW/hp	37/50	37/50
Weight	Approx. kg (lbs)	1,600 (3,527)	1,800 (3,968)
Two-point hitch		-	Standard
Drawbar		Standard	-
Storage length	mm (inch)	8,400 (27'7")	7,300 (23'11")
Rigid tine arms		+	(+)
Folding tine arms		-	(+)
Storage height			
machine with rigid tine arms	mm (inch)	1,300 (4'3")	3,850 (12'8")
machine with folding tine arms	mm (inch)	-	3,400 (11'2")

(+) = Required accessory

+ = Base specification

- = Not available



Swadro 809	Swadro 810	Swadro 907	Swadro 1010
6,800 (22'4")	6,800 (22'4")	8,000 (26'3")	9,700 (31'10")
-	2 x 3,700 (2 x 12'2")		
2	2	2	3
6.5-7 (16-17.3)	6.5-7.5 (16-18.5)	8-9 (19.7-22)	9-10 (22-24.7)
2,995 (9'10")	2,995 (9'10")	2,995 (9'10")	2,995 (9'10")
26	26	30	36
104	104	120	157
3,300 (10'10")	3,300 (10'10")	3,800 (12'6")	1 x 2,960 (1 x 9'9") 2 x 3,600 (2 x 11'10")
+	+	+	-
16x6.50-8	16x6.50-8	16x6.50-8	16x6.50-8
10.0/75-15.3/8 PR	10.0/75-15.3/8 PR	15/55-17/10 PR	15/55-17/10 PR
37/50	37/50	51/70	59/80
1,920 (4,233)	1,980 (4,365)	2,800 (6,173)	2,920 (6,437)
Standard	Standard	Standard	Standard
-	-	-	-
7,770 (25'3")	7,770 (25'3")	8,500 (27'11")	9,800 (32'2")
-	-	-	-
Standard	Standard	Standard	Standard
4,170 (13'8")	4,170 (13'8")	4,400 (14'5")	4,300 (14'1")
3,720 (12'3")	3,720 (12'3")	3,900 (12'10")	3,800 (12'6")



Technical Data

Trailed center-delivery rakes

Model		Swadro 700	Swadro 700 Plus	Swadro 800/26	Swadro 800/26 Plus
Work width	mm (inch)	6,800 (22'4")	6,800-7,600 (22'4"-24'11")	6,800-7,600 (22'4"-24'11")	6,800-7,600 (22'4"-24'11")
Manual work width control		-	Standard	Standard	-
Hydraulic work width control		-	-	-	Standard
No. of rotors		2	2	2	2
Area output	Approx ha/h (acres/h)	6.5 (16)	7 (17.3)	7.5 (18.5)	7.5 (18.5)
Transport width	mm (inch)	2,900 (9'6")	2,900 (9'6")	2,900 (9'6")	2,900 (9'6")
No. of tine arms		20	20	26	26
No. of double tines		80	80	104	104
Separate rotor lift/lower feature		-	Standard	Standard	Standard
Rotor diameter	mm (inch)	3,300 (10'10")	3,300 (10'10")	3,300 (10'10")	3,300 (10'10")
Manual work depth control		Standard	-	Standard	-
Electric work depth control		-	Standard	-	Standard
Central swath deflector		Optional	Optional	Optional	Optional
Lowering running gear		-	-	-	-
Tire size on bogies		16x6.50-8	16x6.50-8	16x6.50-8	16x6.50-8
Tire size on running gear		10.0/75-15.3/8 PR	10.0/75-15.3/8 PR	10.0/75-15.3/8 PR	10.0/75-15.3/8 PR
Power requirement	Approx. kW/hp	37/50	37/50	37/50	37/50
Weight	Approx kg (lbs)	1,550 (3,417)	1,550 (3,417)	1,700 (3,748)	1,700 (3,748)
Two-point hitch		Standard	Standard	Standard	Standard
Drawbar		-	-	-	-
Storage length	mm (inch)	5,725 (18'9")	5,725 (18'9")	5,725 (18'9")	5,725 (18'9")
Folding tine arms		(+)	(+)	(+)	(+)
Rigid tine arms		(+)	(+)	(+)	(+)
Storage height at minimum work width					
Machine with rigid tine arms	mm (inch)	3,995 (13'1")	3,995 (13'1")	3,995 (13'1")	3,995 (13'1")
Machine with folded tine arms	mm (inch)	3,570 (11'9")	3,570 (11'9")	3,570 (11'9")	3,570 (11'9")

(+) = Required accessory

+ = Base specification

- = Not available



Swadro 900	Swadro 900 Plus	Swadro 1000	Swadro 1400	Swadro 1400 Plus	Swadro 2000
7,700-8,800 (25'3"-28'11")	7,700-8,800 (25'3"-28'11")	8,800-10,000 (28'11"-32'10")	11,000-13,500 (36'1"-44'4")	11,000-13,500 (36'1"-44'4")	10,000-19,000 (32'10"-62'4")
Standard	-	-	-	-	-
-	Standard	Standard	Standard	Standard	Standard
2	2	2	4	4	6
8-8.5 (19.7-21)	8-8.5 (19.7-21)	9-10 (22-24.7)	12-14 (29.6-34.5)	12-14 (29.6-34.5)	15-20 (37-49.2)
2,990 (9'9.7")	2,990 (9'9.7")	2,990 (9'9.7")	2,995 (9'10")	2,995 (9'10")	2,995 (9'10")
26	26	30	4x13	4x13	4x13/2x15
104	104	120	208	208	328
Standard	Standard	Standard	Standard	Standard	Standard
3,600 (11'10")	3,600 (11'10")	4,200 (13'9")	3,600/3,300 (11'10"/10'10")	3,600/3,300 (11'10"/10'10")	3,300 (10'10")
Standard	-	-	-	-	-
-	Standard	Standard	Standard	Standard	Standard
Optional	Optional	Standard	Optional	Optional	-
-	-	-	-	Standard	-
16x6.50-8	16x6.50-8	16x6.50-8	16x6.50-8	16x6.50-8	16x6.50-8
10.0/75-15.3/8 PR	10.0/75-15.3/8 PR	15.0/55-17/10 PR	500/50-17/10 PR (560/45-22.5 PR)	500/50-17/10 PR (560/45-22.5 PR)	600/50-22.5 PR (800/45-R 26.5)
40/55	40/55	51/70	59/80	59/80	96/130
2,050 (4,519)	2,050 (4,519)	2,950 (6,504)	4,600 (10,141)	5,400 (11,905)	9,400 (20,723)
Standard	Standard	Standard	Standard	Standard	Standard
-	-	-	Option	Option	-
6,350 (20'10")	6,350 (20'10")	7,000 (23')	8,440 (27'8")	8,500 (27'11")	13,200 (43'4")
+	+	+	+	-	-
-	-	-	-	+	+
4,250 (13'11")	4,250 (13'11")	4,550 (14'11")	4,360 (14'4")	3,995 (13'1")	3,995 (13'1")
3,780 (12'5")	4,250 (13'11")	3,900 (12'10")	3,850 (12'8")	-	-

KRONE Internet



Discover the world at KRONE and browse through our website pages to find facts and figures and also new developments plus a wide range of services. Explore our website and find out how versatile the KRONE world is.



News

Click here to find up-to-the minute information about KRONE – from new product presentations to show reviews. Here you are at the pulse of KRONE life.



Products

Find extensive information on our full product range. This section holds everything you need – from video clips to manuals.



Sales organisation

Here you find a distributor in Japan as well as your local KRONE dealer who will be pleased to support you. This is where you find your KRONE partner who will be pleased to assist you.



Jobs

Would you like to join our company? KRONE is often looking for diligent and motivated staff to work at our farm machinery factory as well as at our commercial trailer production plant. So, this section is always worth a visit.



Media center

The KRONE 'database' holds thousands of documents, pictures, test reports and much more. Here you find very detailed information on KRONE products that are of special interest to you.



Events

Are you in for a KRONE live experience? Check out for KRONE events and look at a machine on show or watch it during a demonstration. After all, there is little that is more effective than a hands-on experience.



Service

Here you find all the service information you require – from a point of contact at the factory to finance schemes for your KRONE machine as well as training schemes for staff and users.



Download Center

Are you looking for a KRONE calendar for your desktop or a smart picture for your presentation? Here, at the KRONE download center, you will find plenty of useful material for a wide range of projects.



Used Machinery

KRONE often has a wide range of demonstration or exhibit machinery on offer. This is a good site to find your KRONE machine. Then contact your local KRONE dealer to arrange the details of a potential purchase.



Parts

24/7... This service gives you the opportunity to find your KRONE part at any time and without waiting. The KRONE Agoparts Portal has an article number and exact description for every part. You can order the part instantly at your local KRONE dealer by sending an e-mail to Agoparts.



KRONE shop

Are you looking for a gift or are you a collector of farm models? Then you should definitely shop around at our KRONE shop. We take your orders at any time of the day.

Your KRONE dealer

Maschinenfabrik Bernard KRONE GmbH

Heinrich-Krone-Straße 10
D-48480 Spelle

Telefon: +49 (0) 5977.935-0
Telefax: +49 (0) 5977.935-339

info.ldm@krone.de
www.krone.de