

Dimensions in mm  
L\* = Dependent on Screed Type (see Specification)

#### Power Unit

Engine:	6-cylinder PERKINS diesel engine, liquid-cooled
Type:	1106D-E66TA
Output:	Nominal: 129.6kW at 2,000 rpm (according to DIN) ECO Mode: 125kW at 1,800 rpm
Fuel Tank:	300 litres
Electrical System:	24 V

#### Undercarriage

Crawler Tracks:	provided with rubber pads
Ground Contact:	2,830mm x 305mm
Suspension:	rigid
Track Tension Adjuster:	spring assembly
Track Rollers:	lifetime grease lubricated
Traction Drive:	separate hydraulic drive and electronic control provided for each crawler track
Speeds:	- Paving: up to 24m/min., infinitely variable - Travel: up to 4.5km/h, infinitely variable
Steering:	by alteration of track running speeds
Service Brake:	hydrostatic
Parking Brake:	spring-loaded multiple-disk brake, maintenance-free

#### Material Hopper

Hopper Capacity:	13 tonnes
Width:	3,265mm
Feed Height:	594mm (bottom of material hopper)
Push-Rollers:	oscillating, displaceable forwards by 100mm

#### Conveyors and Augers

Conveyors:	2, with replaceable feeder bars, conveyor movement reversible for a short time Drive: separate hydraulic drive provided for each conveyor Speed: up to 25m/min., infinitely variable (manual or automatic)
------------	--

Augers:	2, with exchangeable auger blades, auger rotation reversible Diameter: 400mm Drive: separate hydraulic drive provided for each auger Speed: up to 83 revs/min., infinitely variable (manual or automatic) Auger Height: - Standard: infinitely variable by 14cm, mechanical - Option: infinitely variable by 20cm, hydraulic (lowest position 5cm above the ground)
Lubrication:	Centralized Lubrication System with electrically driven grease pump

#### Screed Options

SB 250:	basic width 2.5m, maximum width (TV/TP1) 10m
AB 500:	basic width 2.55m, infinitely variable width 2.55m to 5m maximum width (TV/TP1) 8.5m
AB 600:	basic width 3m, infinitely variable width 3m to 6m maximum width (TV/TP1) 9m
Screed Versions:	TV, TP1, TP2
Layer Thickness:	up to 30cm
Screed Heating:	electric by heating rods
Power Supply:	three-phase A.C. generator

#### Dimensions and Weights

Length:	Tractor Unit and Screed in Transport Position: - SB 250 TV/TP1/TP2: 6m - AB 500/AB 600 TV: 6m - AB 500/AB 600 TP1/TP2: 6.1m
Weights:	Tractor Unit with AB 500 Screed in TV Version: - Pave Widths up to 5m: 19.3 tonnes - Pave Widths up to 8.5m: 21.9 tonnes

#### Optional Equipment

Hydraulic hopper front. Hardtop of glass fibre reinforced polymer material. NIVELTRONIC Plus® for Automated Grade and Slope Control (various sensors available). Sonic sensors to monitor head of mix in front of the screed. Automated Steering Control. Xenon lamps for working lights. For more optional extras please contact your VÖGELE partner.

Key: T = equipped with Tamper P1 = equipped with 1 Pressure Bar SB = Fixed-Width Screed  
V = equipped with Vibrators P2 = equipped with 2 Pressure Bars AB = Extending Screed

Technical alterations reserved.

© ErgoPlus, InLine Pave, NIVELTRONIC, NIVELTRONIC Plus, NAVITRONIC, NAVITRONIC Plus, RoadScan and V-TRONIC are registered Community Trademarks of JOSEPH VÖGELE AG, Ludwigshafen/Rhein, Germany. PCC is a registered German Trademark of JOSEPH VÖGELE AG, Ludwigshafen/Rhein, Germany. NIVELTRONIC Plus and NAVITRONIC Plus are trademarks registered in the US Patent and Trademark Office to JOSEPH VÖGELE AG, Ludwigshafen/Rhein, Germany. Legally binding claims cannot be derived from written information or pictures contained in this brochure. Pictures may include optional extras. We reserve the right of technical or design alterations.

## JOSEPH VÖGELE AG

Joseph-Vögele-Str. 1  
67075 Ludwigshafen · Germany  
marketing@voegele.info

Telephone: +49 (0)621 8105 0  
Fax: +49 (0)621 8105 461  
www.voegele.info

Your VÖGELE QR Code  
leading you directly to  
the SUPER 1800-2 on  
our website.



Tracked Paver

# SUPER 1800-2



## SUPER 1800-2

Maximum Pave Width 10m  
Maximum Laydown Rate 700 tonnes/h  
Transport Width 2.55m

# Innovative Tracked Paver



The VÖGELE SUPER 1800 class is legendary. No other asphalt paver enjoys greater popularity amongst professional road building contractors the world over. SUPER 1800-2, no doubt, is one of the most compact-sized and powerful models around in its performance class covering a wide range of applications.

With a maximum pave width of 10m and a machine length of just 6m, the VÖGELE paver handles motorway projects,

rural roads or the surfacing of large areas with the same high perfection as it copes with confined spaces when tackling roundabouts.

Installed in the SUPER 1800-2 is an engine developing 129.6kW to perfectly serve the paver's capabilities. The machine stands out through high performance and economical operating efficiency alike. Above all when working in ECO Mode, the paver features remarkably quiet operation and low fuel consumption.



Thanks to ErgoPlus®, the VÖGELE concept for paver handling, operators have never had it so good. ErgoPlus® offers a maximum of clarity, simplicity and ease of operation. The operator enjoys a modern workplace of ergonomic design leaving nothing to be desired. This way, the SUPER 1800-2 sets new standards in terms of paver performance, economical operating efficiency and user-friendliness.

## SUPER 1800-2

### At a Glance



- ▶ Maximum pave width 10m
- ▶ Laydown rate up to 700 tonnes/h
- ▶ Maximum layer thickness 30cm
- ▶ Transport width 2.55m
- ▶ Pave speed up to 24m/min.
- ▶ Travel speed up to 4.5km/h
- ▶ Powerful PERKINS engine rated at 129.6kW
- ▶ Comes with ErgoPlus®, the concept for easy paver handling
- ▶ Hardtop with wide sunshades

# Tracked Paver SUPER 1800-2





## Efficient and Eco-Friendly Drive Concept



The SUPER 1800-2 is powered by a modern, liquid-cooled PERKINS engine rated at 129.6kW. The speed ranges MIN, ECO and MAX are available which select conveniently at the push of a button. ECO Mode is sufficient for 70 to 80% of all paving jobs. This mode reduces fuel consumption, wear and noise emissions.

Energy is also saved due to the short time required for heating the screed's compacting systems to operating temperature, even with the engine running at minimum rpm. The right temperature, however, is not important for the screed alone. In all climatic zones the world over, the large cooler assembly and innovative air routing provide for optimal temperature levels of engine coolant, hydraulic oil and charge air, while at the same time keeping noise emissions low.

With the SUPER 1800-2, technology and eco-friendliness go hand-in-hand.



Different speed ranges are available which select conveniently at the push of a button (MIN, ECO, MAX).



- ▶ Powerful PERKINS engine developing 129.6kW at just 2,000 rpm. The modern, low-noise engine complies with exhaust emissions standards COM 3a and EPA.
- ▶ A constant pave speed is one of the crucial factors when it comes to achieving excellent pavement quality. Electronic Engine Management, installed in the SUPER 1800-2, ensures a consistent engine output to match the demand.
- ▶ Powerful three-phase A.C. generator with Generator Management controlling generator output in compliance with the pave width. Heating the screed's compacting systems to operating temperature takes a short time only.
- ▶ Thanks to a large cooler assembly with innovative air routing, perfect cooling of engine cooling liquid, hydraulic oil and charge air. Noise emission is very low.
- ▶ A constantly high cooling capacity provides for ideal temperatures inside the hydraulic system and top performance of all drive units even when working under full load, in all climatic zones the world over.
- ▶ For hydraulic functions, powerful separate drives are installed operating in closed circuits, thus delivering highest outputs.



# High Precision on Tracks



Even difficult terrain is no problem for the SUPER 1800-2 thanks to its powerful crawler tracks and accurate steering. In terms of traction, too, the VÖGELE drive concept leaves nothing to be desired.

- Thanks to powerful separate drives fitted into the sprockets for crawler tracks, engine output is translated into pave speed with no loss of power.
- Long crawler tracks with large footprints provide for maximum tractive effort, allowing the paver to get on well at a constant speed even when operating on difficult terrain.
- Positive tracking when moving straight and accurate turning of radii due to separate drive and electronic control provided for each crawler track.

# Large Material Hopper, Easy Feed with Mix



Like all VÖGELE pavers, supply of the SUPER 1800-2 with mix is a clean and safe process passing off swiftly. Thanks to a hydraulically operated hopper front (option), the mix inside the material hopper is directed right onto the conveyors and the entirety of mix properly conveyed in front of the screed.

- ▶ The large material hopper holding 13 tonnes is amply dimensioned so that a sufficient quantity of mix is stored at all times. No problem to tide over difficult situations such as paving under bridges, for instance.
- ▶ Easy feed with mix thanks to low material hopper, wide hopper sides and sturdy rubber baffles fitted to the hopper front.
- ▶ Large oscillating push-rollers for convenient and shock-free docking of feed vehicles, even in curves.

# Prime Paving Quality Due to Perfect Material Handling



Due to perfect spreading of mix, the SUPER 1800-2 provides for an optimal head of material in front of the screed in every paving situation. Powerful, separate hydraulic drives for conveyors and augers are installed achieving laydown rates up to 700 tonnes/h.

- Proportional control and continuous monitoring provided for conveyors and augers guarantee a constant head of mix in front of the screed in conformity with the requirement.
- The height of the auger, complete with bearing boxes and limiting plates for the auger tunnel, is infinitely variable by up to 20cm across the entire pave width. This results in optimal spreading of mix in front of the screed, even when paving thin layers.
- Large diameter of auger blades (400mm) for excellent spreading of mix when paving in large widths.
- An auger tunnel, easily variable in depth, provides for an optimal flow of mix when paving thick layers.

## Easy Maintenance, Long Intervals Between Maintenance Services



The well-thought-out maintenance and service concept is perfectly geared to the requirements of the workshop and service staff.

- ▶ A wide engine hood and large hinged panels give convenient access to service points on the machine.
- ▶ All hydraulic pumps attached to the transfer gearbox. Their clear arrangement and easy access provides for service-friendliness at the highest level.
- ▶ Centralized lubrication system installed to automatically supply required amounts of grease to bearings of conveyors and augers.
- ▶ Sturdy components of highly wear-resistant materials for long service lives minimize downtime.
- ▶ A standardized service concept for all VÖGELE pavers simplifies maintenance and cuts expenditure on training.

# VÖGELE ErgoPlus®

## The User-Friendly Operating System

**ERGOPLUS**

Even the best machine with the most advanced technology can only really show its strengths if it can be operated easily and as intuitively as possible, and offers to the operator a maximum of ergonomic comfort and workplace safety. Therefore, the ErgoPlus® operating concept focuses on the operator.

The example diagrams on the following pages will provide you with additional information on the extensive functions of the ErgoPlus® operating concept. ErgoPlus® encompasses the operator's stand, the paver operator's and screed consoles and NIVELTRONIC Plus®, the System for Automated Grade and Slope Control.

The operating consoles are designed for optimum clarity, presenting all paver functions in logical groups. There's a place for everything and everything in its place on the operator's stand, and the paver operator has an excellent overview of all the key points of the paver.

All told, the ErgoPlus® operating concept enables the operator to respond to job site working processes and situations more quickly and accurately, giving him total control over the machine and the project.



ErgoPlus® Paver Operator's Console



ErgoPlus® Screed Console

## The Strong Points of ErgoPlus®

- ▶ Operator platform of streamlined design and well organized for a high level of safety at work.
- ▶ The paver operator's seats and the operating console adjust conveniently and easily in keeping with his personal needs. This provides a maximum of ergonomic comfort.
- ▶ All vital paver functions are clustered in logical groups on the paver operator's console. Their operation is easy to learn.
- ▶ Easy operation of VÖGELE NIVELTRONIC Plus®, the System for Automated Grade and Slope Control, to achieve perfect paving results.
- ▶ The ErgoPlus® paver operator's console is of modular design. This smart concept is not only ideal in practice, but also saves costs. In case of need, it offers the great advantage of easy replacement of single modules without having to replace the entire unit.



ErgoPlus® Operator Stand



# THE ErgoPlus® PAVER OPERATOR'S CONSOLE

Full Control for the Machine Operator





# THE ErgoPlus® PAVER OPERATOR'S CONSOLE

Clear and Logical Arrangement of Controls

## Examples of Paver Functions



### Reversing Conveyor Movement

In order to avoid mix dropping from the conveyors during a move of the paver on the job site, conveyor movement can be reversed at the push of a button. Reverse movement, transferring mix from the rear of the conveyor tunnel back inside, takes place for a short time only and stops automatically.



### No-Load Function

The No-Load function is provided for warm up or cleaning of conveyors, augers and tamper.



### Automatic Functions

For conveyors and augers, operators can easily select "Manual Mode" or "Automatic Mode". When selecting "Automatic Mode" for the augers, sensors installed for the mix level in the auger tunnel provide that exactly the desired amount of mix is spread in front of the screed.



### Choice of Operating Modes for the Paver

On the ErgoPlus® console, 4 different operating modes for the paver are available to select from. By pressing the arrow buttons, up or down, the operator changes modes in the order as follows: "Neutral", "Job Site Mode", "Positioning Mode" and "Pave Mode". A LED indicates the mode selected. When leaving "Pave Mode", a smart Memory feature stores last settings for paver functions so that, when resuming work after a move of the paver on site, these settings are restored automatically.

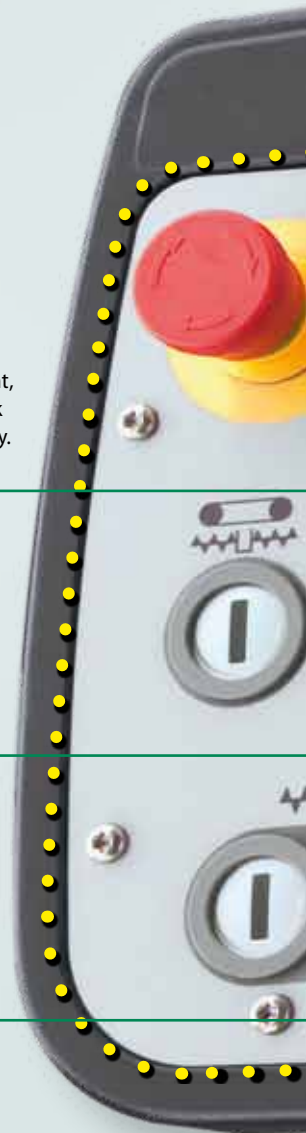

The ErgoPlus® paver operator's console has been designed according to practice-related principles. All controls are clearly arranged. Paver functions are clustered in logical groups so that operators find their controls where they suppose these should be.

On the ErgoPlus® console, all push-buttons are easily identifiable by touch even when wearing work gloves.

Once a button is pressed, off you go. This is due to the "Touch and Work" principle. This means that a function is executed directly – without a need to confirm.

As darkness falls, the paver operator's console is back-lit automatically, as you have it in your car. This makes night-time work easy and relaxed.

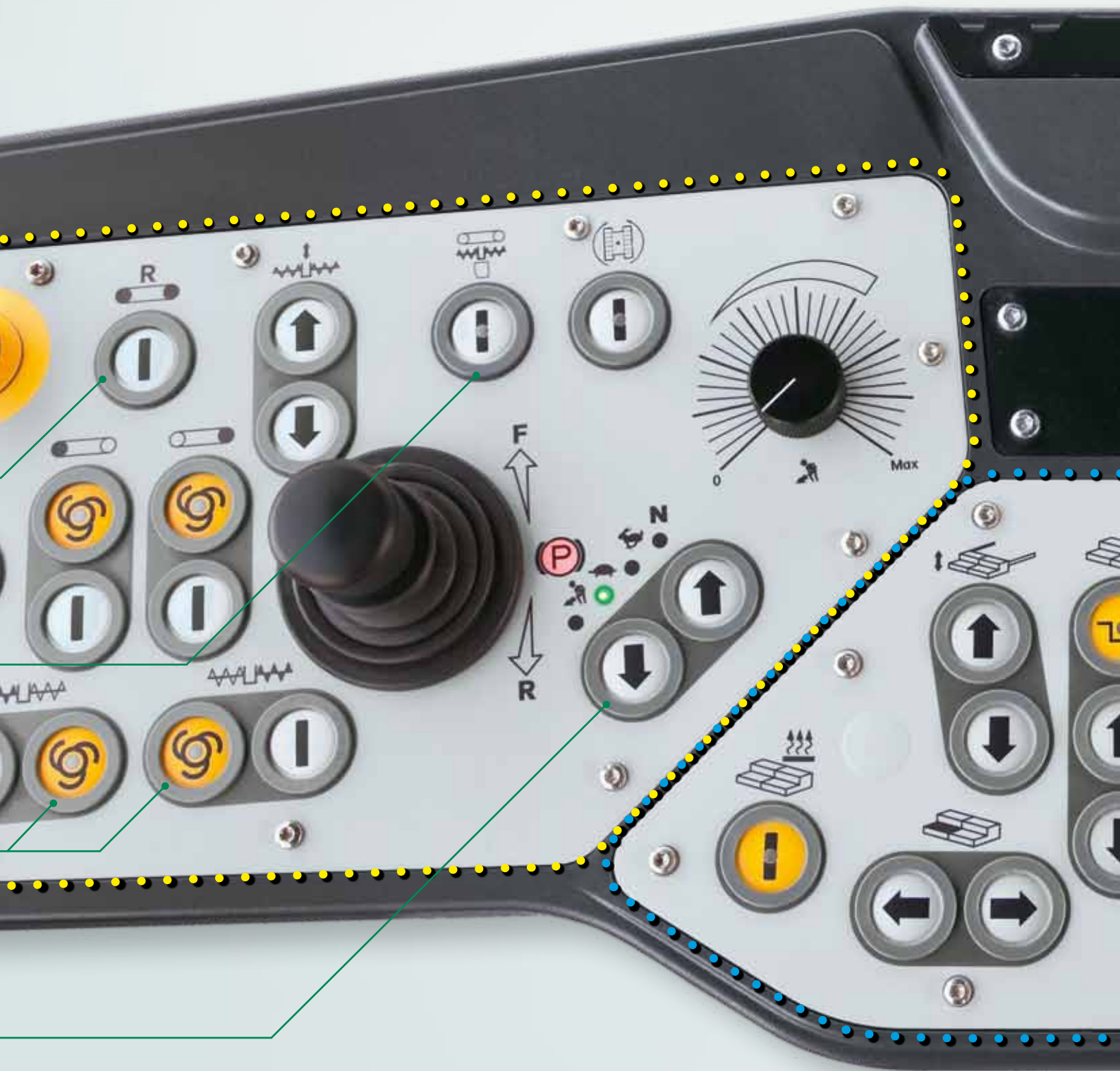



● ● ● ● ● ● **Module 1:**  
Conveyors and Augers, Traction

● ● ● ● ● ● **Module 2:**  
Screed

● ● ● ● ● ● **Module 3:**  
Material Hopper and Steering

● ● ● ● ● ● **Module 4:**  
Display for set-up of vital paver functions on menu level 1.  
Secondary functions on menu level 2.

#### Display of the Paver Operator's Console

The large, easy-to-read display shows vital information on menu level 1 – such as the positions of the screed tow point rams or the pave speed. Set-up of further paver functions such as speeds for tamper and vibrators or feed rate for the conveyors can easily be made via the display, too. And the display gives access to machine-related information such as fuel consumption or service hours.



#### Steering

For turning a large radius, fine steering allows to pre-set a track position which is maintained automatically without a need for manual intervention by the operator.



#### Choice of Engine Speed Ranges

For the engine, 3 modes exist to select from: MIN, ECO and MAX. To swap modes for engine rpm, all the operator needs to do is press the arrow buttons, up or down. In ECO Mode, the engine delivers sufficient power for a great number of paving applications. Operating in ECO Mode reduces noise emission and fuel consumption considerably.



#### Screed Assist (Option)

This button switches Screed Assist on (LED lights up) or off. Screed Assist pressure and balance can be set via the display. Screed Assist is active only when the screed floats.





# THE ErgoPlus® SCREED CONSOLE

## Easy Operation Guaranteed

Crucial for pavement quality is the screed. Therefore, easy and positive handling of all screed functions is of utmost importance for high-quality road construction.

With ErgoPlus®, the screed operator has the process of paving at his fingertips. All functions are easily comprehensible and all controls are clearly arranged.

### The Screed Console

The screed console is designed in keeping with the conditions prevailing on the job site. These are watertight and enclosed in perceptibly raised rings, so that they are identifiable blindfold simply by touch even when wearing work gloves. Important paver and screed data can be called up and adjusted from the screed console, too.



### The Display of the Screed Console

The display of his console allows the screed operator to control and monitor both the left and the right side of the screed. Machine-related parameters such as tamper speed or conveyor speed can be adjusted conveniently via the display panel of the screed console. The clear menu structure, combined with easily understandable, self-explanatory symbols neutral in language, makes operating the display panel both simple and safe.



### NIVELTRONIC Plus® (Option)

NIVELTRONIC Plus®, the cutting-edge VÖGELE System for Automated Grade and Slope Control, is very easy to learn and achieves outstanding paving results. All important functions of NIVELTRONIC Plus® can be accessed directly on menu level 1. The operator is provided with a variety of information, such as the sensor currently selected or the specified and actual values for layer thickness.

An electronic system installed in the screed tow point rams picks up the tow points' positions. Display of the current tow point positions and of the transverse slope on the screed console greatly facilitates set-up of the screed. All sensors connected are recognized automatically by NIVELTRONIC Plus® and can be monitored and controlled from either screed console. An open interface is provided for connection of a GPS system, thus permitting 3D paving.



### Automatic Mode for Augers, Reversing Auger Rotation

Just like the paver operator, the screed operator, too, can select Manual Mode or Automatic Mode for conveyors and augers. Very useful and comfortable in practice is the function of "Reversing Auger Rotation".



# THE ErgoPlus® OPERATOR STAND



## Excellent All-Round Visibility

- ▶ The comfortable operator stand gives unobstructed view of all crucial areas on the paver such as material hopper, steering guide or screed. It allows the paver operator to closely monitor the paver's feed with mix and the process of paving.
- ▶ The seats swinging out to the sides and an operator stand of streamlined design provide for maximum visibility of the auger tunnel, thus permitting the paver operator to keep an eye on the head of mix in front of the screed at all times.

## Working Comfort

- ▶ A few adjustments are all it takes for the paver operator to position his console exactly in keeping with his personal needs. It can be displaced across the full width of the operator's stand, swivelled out to the sides and tilted.
- ▶ When working with the seat swung out, the paver operator's console can be swivelled out together with the operator's seat. In this way, an ergonomically optimized workplace is set up in no time at all. A legroom kept warm adds to operator comfort during the cold season.



## A Place for Everything and Everything in its Place

- ▶ The operator's stand of streamlined design is well organized, so that the paver operator enjoys a professional workplace.
- ▶ The operator's console can be protected by a shatter-proof cover to prevent wilful damage.
- ▶ Plenty of stowage space makes it easy to keep the machine tidy. Access to all vital service points on the machine has been designed to be extremely clear and ergonomic.

## Hardtop Gives Excellent Protection

- ▶ The modern hardtop made of glass fibre reinforced polymer material shelters the operator whether rain or shine. The hardtop, including exhaust pipe, raises up or lowers down quickly and with effortless ease by a manually operated hydraulic pump. Wide sunshades, extending easily, give the operator optimal protection when his seat is moved out.
- ▶ Six bright working lights are integrated into the hardtop. Raising the lights in this way floods the job site with light (Xenon lamps available as an option).



# Screed Options for All Paving Applications



A powerful tractor unit calls for a screed to match. Each application has its particular requirements, so that in the end it's up to the users' everyday tasks to decide which screed is the right one. For SUPER 1800-2, we offer a number of screed options and versions as far as equipment with compacting systems is concerned.

- ▶ VÖGELE Extending Screeds feature a high degree of variability. AB 500 and AB 600 come with a sturdy single-tube telescoping system. Working with highest precision, they offer quick screed width control accurate to the millimetre.
- ▶ A Screed Assist feature to be set electronically and separately for the left and right-hand sides, is offered as an optional extra. Screed Assist supports the paving team when working under difficult conditions.
- ▶ SUPER 1800-2 can also be combined with the SB 250 Fixed-Width Screed. The screed easily builds up to a maximum width of 10m using bolt-on extensions.



▶ All screeds are available in TV version (with tamper and vibrators) for standard compaction or in TP1 or TP2 versions (with tamper and 1 or 2 pressure bars) for the unique VÖGELE high compaction.

▶ **Transverse Pavement Profiles**

- Positive and negative crown can be paved with all screed types.
- The AB screeds' extending units adjustable in height and spindles provided on either side of each extending unit allow the Extending Screeds to be set up to a variety of additional special profiles.

▶ **Electric Screed Heating**

- Homogeneous surface texture thanks to uniform heating of screed plates, tamper bars and pressure bar(s).
- Even with the paver's engine running at minimum rpm, the time required for the screed to reach its operating temperature is reduced substantially thanks to an intelligent Generator Management.
- With paver functions set to automatic, the Generator Management activates Alternating Mode for screed heating (heats the screed alternately to left and right), a feature which is easy on the engine and reduces fuel consumption considerably.

# The Screed Options for SUPER 1800-2



## AB 500

### Pave Widths

- Infinitely variable range from 2.55m to 5m.
- Larger widths by addition of bolt-on extensions up to a maximum of 8.5m.

### Compacting Systems

- AB 500 TV with tamper and vibrators
- AB 500 TP1 with tamper and 1 pressure bar
- AB 500 TP2 with tamper and 2 pressure bars



## AB 600

### Pave Widths

- Infinitely variable range from 3m to 6m.
- Larger widths by addition of bolt-on extensions up to a maximum of 9m.

### Compacting Systems

- AB 600 TV with tamper and vibrators
- AB 600 TP1 with tamper and 1 pressure bar
- AB 600 TP2 with tamper and 2 pressure bars



## SB 250

### Pave Widths

- Basic width 2.5m. Larger widths by addition of bolt-on extensions up to a maximum of 10m.
- Thanks to 75cm hydraulic bolt-on extensions, pave width is infinitely variable within a range of 1.5m.

### Compacting Systems

- SB 250 TV with tamper and vibrators
- SB 250 TP1 with tamper and 1 pressure bar
- SB 250 TP2 with tamper and 2 pressure bars

Example: AB 500 in TV or TP1 versions built up to maximum pave width

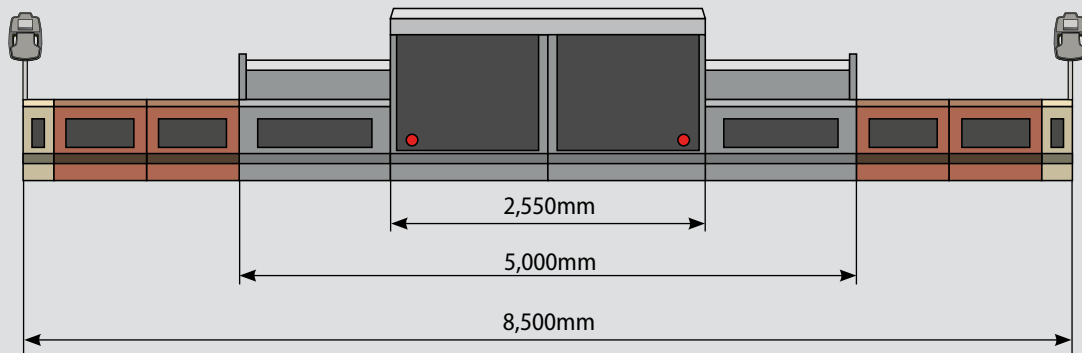

Example: AB 600 in TV or TP1 versions built up to maximum pave width

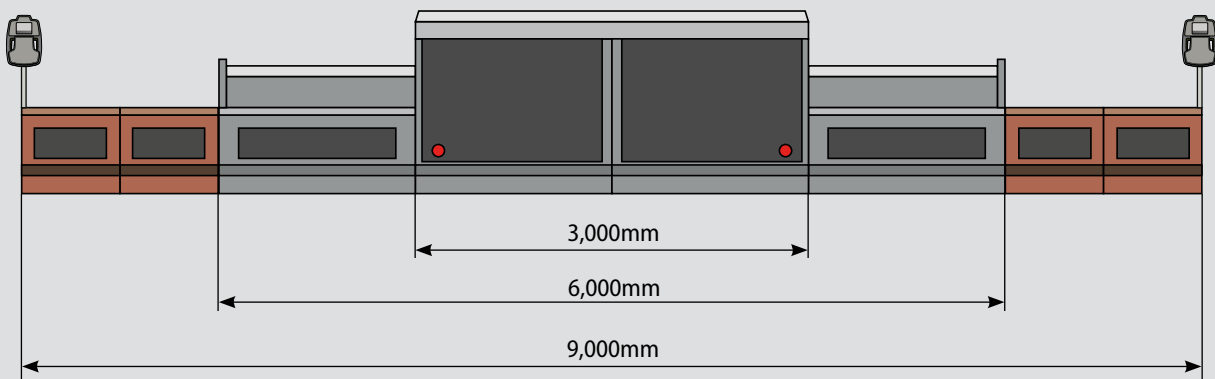

Example: SB 250 in TV or TP1 versions built up to maximum pave width

