



SPK 42502 - MH

- Electronic Overload Protection (Paltronic 50) and Emergency Stop Button
- Up to 10% increased lifting capacity with High Power Lifting System (HPLS)
- High speed boom extension and refraction with Return Oil Utilization feature
- Optimized lifting performance with the use of high tensile steel and hexagonal boom design
- Light weight yet robust construction according to European standards (EN12999)
- Optional Overload Protection and Emergency Stop Button
- Professional Installation Solutions
- Suitable for installation on 3-axle trucks

42.3 mt

Max. lifting
moment

16.8 m

Max. outreach

TECHNICAL SPECIFICATIONS (EN 12999 H1-B3)

Max. Lifting Moment	mt	42.3
Max. Lifting Capacity	kg	14340
Max. Outreach	m	8.0 (A) / 12.1 (C) / 16.8 (E)
Slewing Angle	o	400
Slewing Torque	mt	5.0
Stabilizer Spread	m	6.6 (R3X)
Fitting Space Required (Std)	m	1.21
Width Folded	m	2.5
Operating Pressure	bar	330
Recommended Pump Capacity	l/min	80 - 100
Dead Weight (Std)	kg	3970

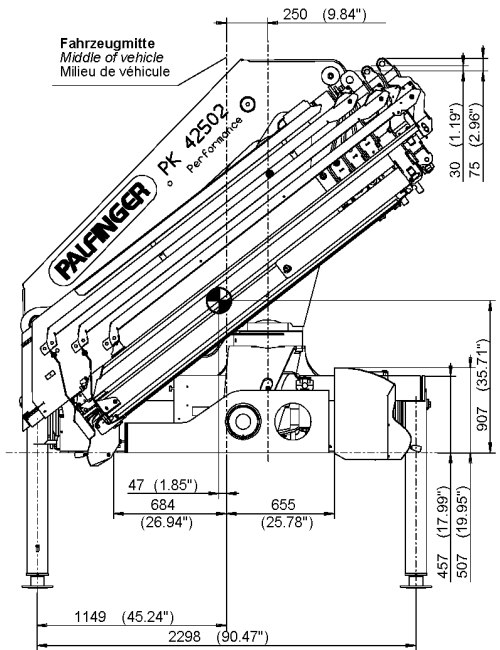

SPK 42502 A

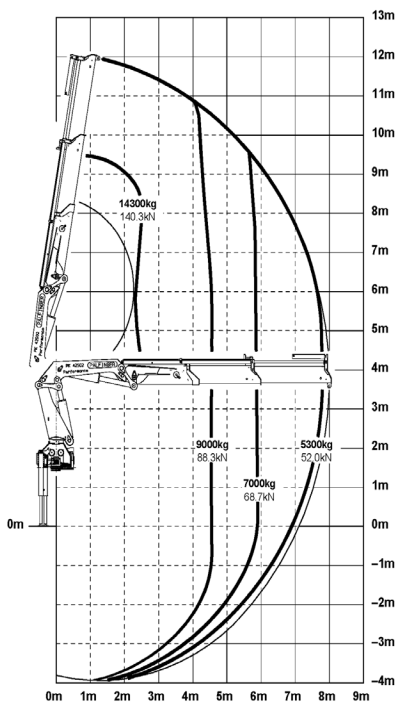

SPK 42502 E

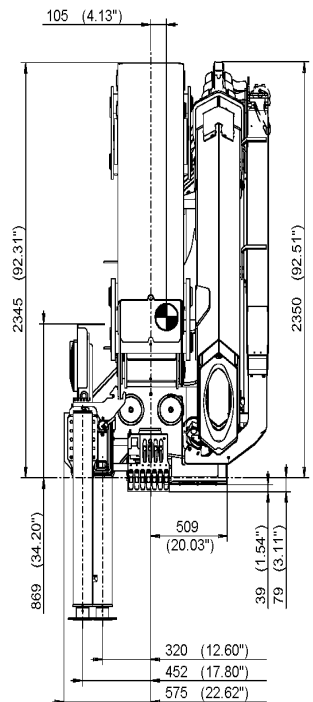
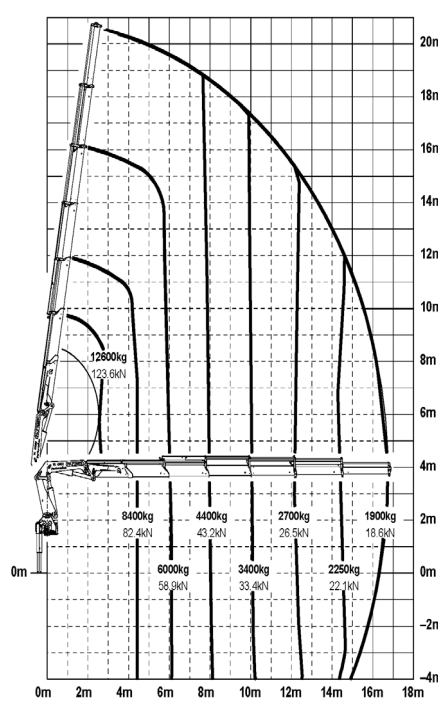

Authorized Dealer:

Units shown in the leaflet are partially optional equipped and do not always correspond to the standard version. Country-specific regulations must be observed. Dimensions may vary. Subject to technical changes, errors and translation mistakes.

Asia Pacific Distributor Managed By:

PALFINGER ASIA PACIFIC PTE LTD

3 International Business Park | Nordic European Centre
#05-25/26 | Singapore 609927

T +65 6592 9192

asia@palfinger.com

F +65 6591 7737

www.palfinger.com