

Integrated mechanical seed drills



INTEGRATED SEEDBED CULTIVATORS CD 1020
POWER HARROWS HR 1020 / 1030 / 1040
SEED DRILLS SITERA 3010 / 3020 / 3030

www.kuhn.com



be strong, be **KUHN**



CD

HR

SITERA

THE ADAPTABLE DRILL COMBINATION

YOU ARE LOOKING FOR EASY SETTINGS?

With the SITERA seed drill you have a great ease of use thanks to the centralised continuous adjustment of the seeding depth. You can also control the machine with an ISOBUS CCI terminal or the tractor's ISOBUS terminal, but also using the new VT 30 terminal.

YOU WANT A PLEASANT DRIVING EXPERIENCE?

The new design, the perfect visibility, the balanced load distribution and the advanced hopper are all elements designed to allow you to experience a pleasant drive at work as well as during transport.

Table of contents:

Seedbed cultivators CD 1020	4
Power harrows HR 1020 / 1030 / 1040	5
SITERA 3010 / 3020 / 3030	8
Electronics	10
Technical specifications	12

HIGH OUTPUT IN LIGHT SOILS

In order to produce top layers that are favourable to germination, it is crucial to crumble the surface centimetres of the soil. Moderate soil levelling will ensure seed-to-soil contact. Discs take care of weed and residue elimination. With KUHN's CD disc cultivator you can simplify or adapt the «ideal» seedbed preparation method by changing the tillage tool in less than 10 minutes.



1

1. SPECIALLY DESIGNED DISCS

Get a great job done with 400 mm-diameter notched discs! Disc arms are fitted to a specifically-profiled tube which maintains constant working depth.



2

2. LOWER POWER REQUIREMENT

The CD / VENTA seeding combination is designed to have its centre of gravity close to the tractor. The notched discs and large-diameter roller reduce energy consumption. The heavy-duty frame is designed to work at high speeds.



3

3. A LONG LIFE

The heavy-duty and reliable frame is specially designed and adapted to working at high speeds. The cross-shaped tube keeps the working discs in place thanks to long-life elastomer blocks.



4

4. NO MAINTENANCE

Neither the polyurethane blocks nor the disc bearings require maintenance. They are lubricated for life.



5

5. SIDE DELECTORS FOR A PERFECT FINISH

For a perfect finish between two passes, KUHN's CD 1020 series cultivator is equipped with deflectors which are mounted on a parallelogram to ensure smooth soil flow.



A PERFECT SEEDBED IN ALL CONDITIONS

With hydraulic settings, it is possible to adapt the machine in real time to working conditions. KUHN's new range of HR power harrows has a model to suit every situation as well as options adapted to your requirements. We offer you accessibility and ease-of-use with working widths of 3 to 4.5 m.

1. EXTRA LONG, STRAIGHT BLADES

This specific design helps create a perfectly fine tilth with a working depth down to 20 cm. The 1040 series features 335 mm blades to perform in the most exalting conditions.



1

2. A ROTOR THAT ADAPTS TO CONDITIONS

Duplex gearboxes make it possible to adapt rotor speed to working conditions. Speed can vary between 255 and 539 rpm for the 1040 series to achieve excellent seeding quality in very difficult conditions.



2

3. LEVELLING BAR ADJUSTMENT

Depth and levelling bar tilt are hydraulically adjustable from the cab to suit conditions, according to the model. The levelling bar is fitted to the roller frame which enables you to adapt traction power requirement.

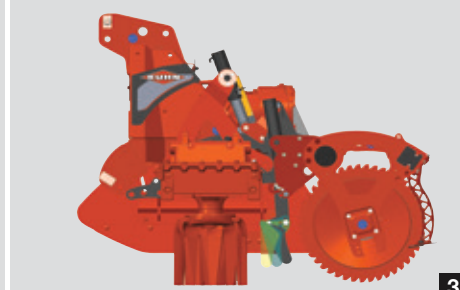

3

4. TRACK ERADICATORS

Optional track eradicators break up the soil compacted by the tractor wheels.

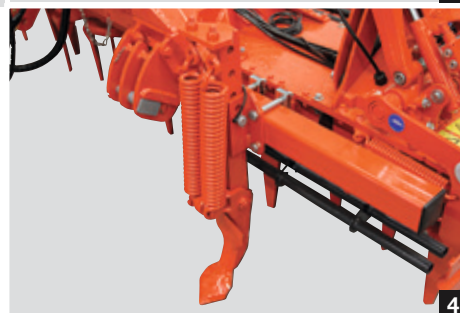

4

5. SIDE DEFLECTORS FOR A PERFECT FINISH

The special long design of these side deflectors ensures a perfect finish between two passes. They are quick and easy to adjust with spring safety and double-arm attachment for optimum hold.



5



THE BENCHMARK FOR RELIABILITY

KUHN's new range of HR power harrows provides flexibility and reliability. We have used high quality parts so that you can work in any conditions for as long as possible.

1 A GEARBOX WITH A DIFFERENCE

The central gearbox is equipped with an oil cooling system on 1040 series machines. The integrated pump and additional oil tank cools the oil before re-injecting it into the gearbox.

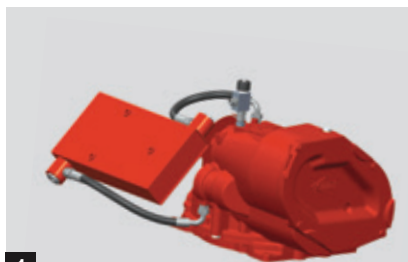

1

2 STONE DEFLECTORS

In stony conditions, V-shaped deflectors protect the central beam from impacts. Being attached with bolts, they are easy to remove for deeper, faster operations.



2

3 YOU DECIDE

With the KSL 14 function selector, control the following functions from the cab: rotor and levelling bar working depth, raising and ground pressure of the coulters bar.



3

4 MORE LINKAGE POSSIBILITIES

Coupling type is of category 3 and 4 with the possibility of adapting to large tractors for cat. 4 quick hitch. It is possible to position the machine closer to the tractor: the central gearbox is shifted backward to reduce the angle with the PTO.



4



OPT FOR FAST-FIT BLADE ATTACHMENT

STANDARD

The standard blades are equipped with a quick release system. They are of a straight shape with a length of 315 mm (1020 and 1030 series) and 335 mm (1040 series).



DURAKUHN

KUHN power harrows can be equipped with optional fast-fit blades coated with tungsten carbide for an even longer service life. No more downtime replacing blades.



HEAVY-DUTY, RESISTANT, RELIABLE... COPIED BUT NEVER EQUALLED!

HR 1040 series power harrows are adapted to powerful tractors up to 320 hp. They are equipped with oil coolers as standard as well as hydraulic adjustments. The high-capacity gearbox will allow you to work in the most demanding conditions.

1 NO OVERHANG

Convex forged and treated gearwheels with no overhang in relation to the bearings. Long splines and gearwheels produce smooth gear transmission.

2 MAINTENANCE-FREE HIGHLY RIGID TROUGH

8 mm thick profiled trough made from fine grain high-tensile steel. It contains semi-liquid grease which ensures lifelong lubrication of pinions and gearwheels. O-rings and lip joints ensure sealing and a long life.

3 NO MAINTENANCE ON BEARINGS

Large conical roller bearings are loaded with a calibrated spacer. They are perfectly aligned in their housing with no play.

4 FAST-FIT BLADES AS STANDARD

The blades are equipped with a quick-release system as standard for less downtime.

5 REINFORCED SEALING

A cassette seal provides very efficient protection against bearing pollution.

6 PERFECT BEARING HOLD

28 mm thick cast iron rectangular housings ensure protection against wear and distortion.

7 ROUNDED BLADE HOLDERS

This specific shape provides smoother operations with less lateral soil pushing, resulting in lower power consumption.

8 PATENT

RELIABLE SPLINES

Rotor shafts with rolled splines are obtained by metal compression. Perfect connection with the shaft thanks to the conical centering of blade holders (KUHNS patent), preventing any spline play.

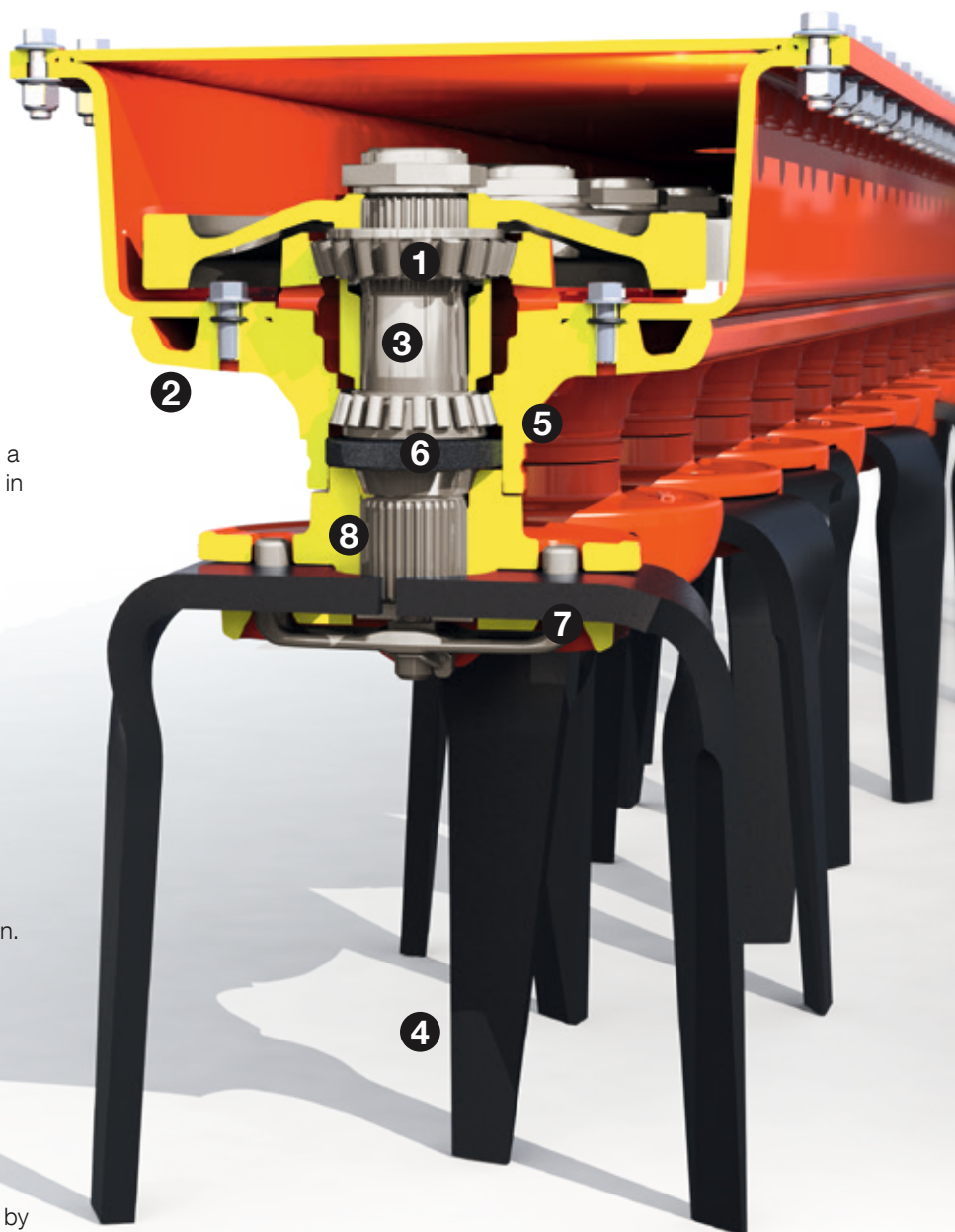

HIGHER PRECISION UNDER ALL CONDITIONS

SITERA 3010 FOR SOWING IN ALL TYPES OF CLAY

The SITERA 3010 seed drill is fitted with seeding units featuring Suffolk coulters requiring little maintenance. Their adjustable lower stop and 35 kg coulters pressure per unit ensure continuously optimum seeding depth in particular in sticky soil or after ploughing. Take advantage of the 28cm row spacing and the three rows of coulters to seed in all types of clay. The parallelogram allows adjusting the coulters bar height by positioning the lower stop at the required depth.



SITERA 3020 FOR SOWING IN PLANT RESIDUES

The SITERA 3020 mechanical seed drill is equipped with a double disc coulters bar fitted over 2 rows 25 cm distant for sowing in difficult conditions. The disc coulters pressure of up to 35 kg ensures a regular seeding depth even in irregular soils. The covering harrow fitted on a parallelogram provides a perfect seedbed finish also in soils with plant residues and in heavy or high soils. Press wheels are available as option for precise control of the seeding depth of each unit.

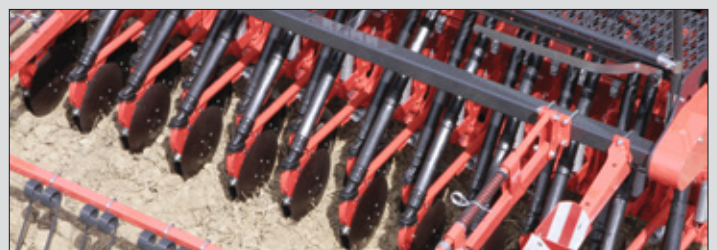

SEEDFLEX: THE PRECISION COULTER BAR

The SITERA 1030 integrated mechanical seed drill is equipped with a SEEDFLEX coulters bar with offset double discs for perfect furrow opening. The double discs are mounted on a parallelogram with press wheel that controls the depth of each seeding unit with precision. 35 cm spacing between the front and rear rows makes SEEDFLEX seeding units suited to different uses including extreme conditions and with no maintenance.



SEEDING DEPTH RESPECTED, EVEN AT HIGH SPEEDS:

Seeding unit mounted on a parallelogram.
Depth control wheel on each row.

PATENT

PATENTED SETTING KINEMATICS

BETTER SOIL/SEED CONTACT:

Depth control and press wheels control seeding depth row by row to ensure dynamic germination.

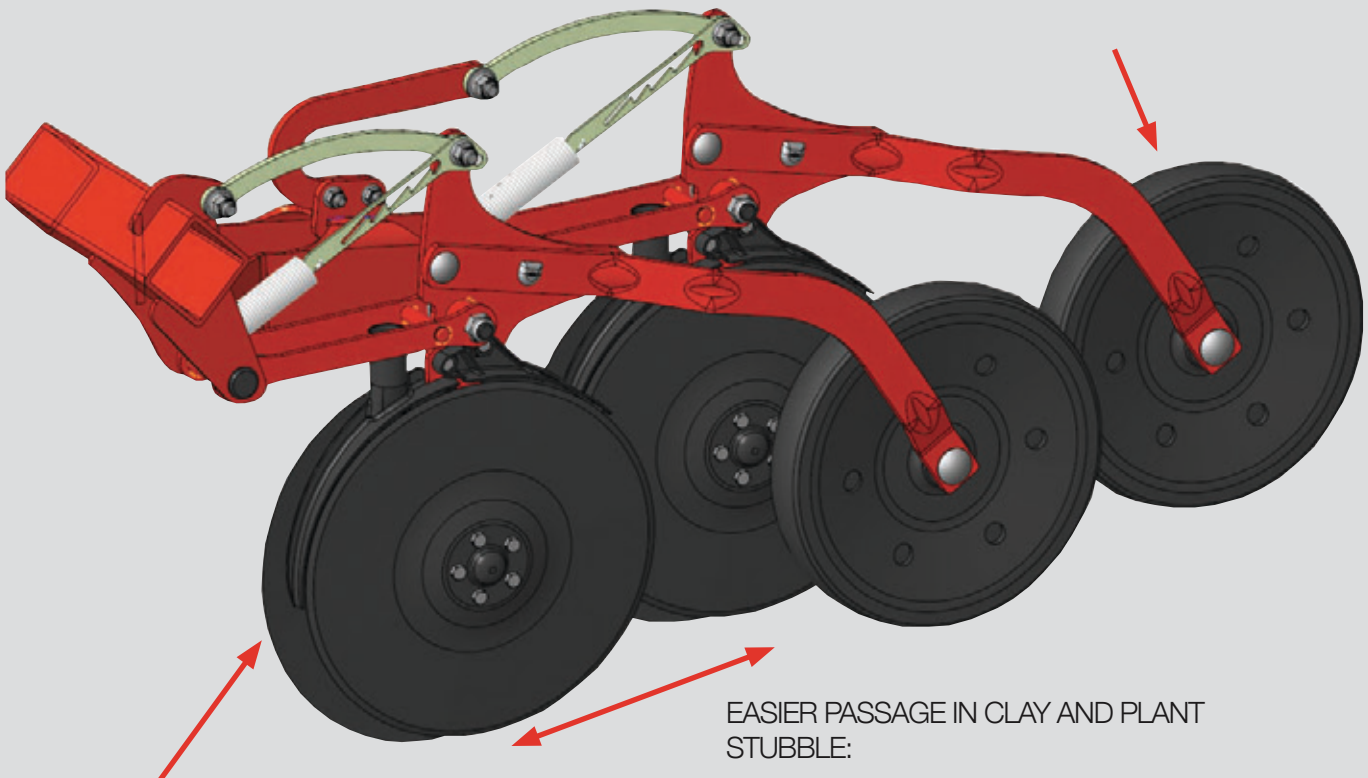

EASY SOIL PENETRATION:

41mm offset double discs for clean furrow opening.
Small opening angle to limit soil ejection in the row and for easier furrow closing.

EASIER PASSAGE IN CLAY AND PLANT STUBBLE:

Seeding rows offset 35 cm.

COMPACT, SIMPLE AND PRECISE COMBINATION

The hopper has been advanced, which reduces on the one hand the overhang of the unit for more comfortable driving and allows on the other hand to have a very good visibility on the coulter bar at work.

CENTRALISED ADJUSTMENTS: GAIN IN SPEED AND PRECISION

Take advantage of the centralised, continuous adjustment of the seeding depth with an adjustment point with indicator on each side of the machine. The patented setting kinematics of the SEEDFLEX coulter bar allow exerting the same pressure on the front and rear seeding units.



EASY HOPPER LOADING

Easy loading of the hopper thanks to its large opening 2.5 m x 0.84 m. The cover opens with an angle of 110 ° to allow you to fill a large capacity hopper: 800 L.

BENEFIT FROM A PERFECTLY INTEGRATED COMBINATION

The hopper is positioned above the roller frame, so as to obtain a low overhang of the unit owing to the advanced center of gravity of the combination. The single tube chassis provides very good visibility on the seeding units at work and on the covering harrow. The adaptation of the tillage tool, i.e. the CD seedbed disc cultivator or the power harrow is done in less than 10 minutes thanks to a patented adaptation part that facilitates the SITERA seed drill's assembly and dismantling.



KUHN ISOBUS SOLUTIONS

The new AEF-certified ISOBUS CCI 1200 terminal focuses on three priorities: performance, visibility and flexibility. It allows controlling intuitively your machines thanks to its antiglare touchscreen of large size 30.5 cm (12.1»). It is capable of displaying simultaneously different essential information, to support the connection of joystick control and the connection of a camera. Among the most innovating applications, it is compatible with a biomass sensor, capable of carrying out Section Control, guidance assistance and modulating / controlling application rates per GPS!

CCI 1200

A NEW ISOBUS TERMINAL FOR KUHN MACHINES. At the cutting edge of technology, discover the AEF-certified ISOBUS terminal, which offers a multitude of applications as standard.



Display of work achieved
(guiding lines and application adjustment map)

ISB palm button to deactivate the
functions of an equipment

Display inversion key /
Change to maxview

2 USB ports for data /
modulation map transfer

Machine display

Brightness sensor

Video input



Display of several miniviews

Documentation /
Work recording

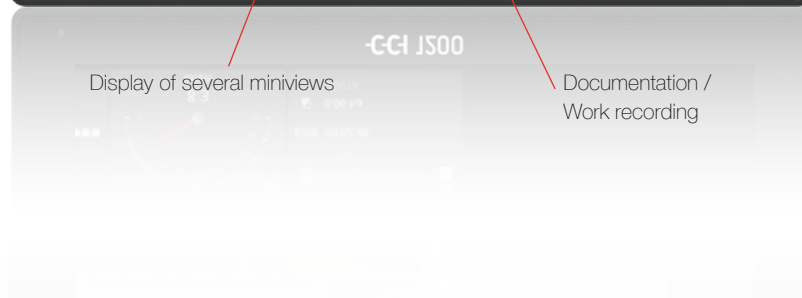

KUHN ISOBUS SOLUTIONS

This AEF-certified terminal is the master of versatility with its 14.2 cm (5'6") colour touchscreen. Benefit from connection of a camera or a biomass sensor. Other functionalities will win you over such as the Section Control (section or row shut-off, variable width...), the application rate adjustment per GPS or even the guidance assistance.

CCI 50

COMPACT AND COMPREHENSIVE. Check the AEF-certified ISOBUS CCI 50 terminal, which groups the basics while remaining highly versatile.



ADAPED TO NON-ISOBUS SYSTEMS WITH THE TERMINAL VT 30

Especially simple and intuitive, the new VT 30 terminal with a 3.5" colour touchscreen features a variety of functions: monitoring of seed level, metering unit rotation, automatic tramlining management by rhythms (symmetric, asymmetric and special), low hopper level alarm, hectare counters and calibration assistant.



Specifications	SITERA 3010		SITERA 3020		SITERA 3030	
	SITERA 3010-20	SITERA 3010-24	SITERA 3020-20	SITERA 3020-24	SITERA 3030-20	SITERA 3030-24
Working width (m)	3					
Transport width (m)	3					
Hopper capacity (l)	800					
Approx. loading height (cm)	189					
Approx. hopper opening dimensions (cm)	250 X 84					
Cover	Metal with anti-dust seal					
Distribution drive	Mechanical by variator					
Agitator	◆					
Volumetric metering unit	HELICA with helical fluted splines - 1 to 450 kg/ha					
Number of valves	2 x 2 rows in symmetrical or asymmetrical rhythms					
Number of rows	20	24	20	24	20	24
Spacing (cm)	15	12.5	15	12.5	15	12.5
Compatibility with treatment widths (m)	12 - 15 - 18 - 21 - 24 - 27 - 30					
Seeding unit	Trailing coulters over 3 rows 28 cm distant		Double disc coulters fitted over 2 rows 25 cm distant		35 cm offset double disc SEEDFLEX units fitted on parallelogram	
Disc hard coated inner scraper	-		◆			
Seeding depth adjustment	Manual centralised					
Electronic equipment	ISOBUS CCI terminal or tractor ISOBUS terminal or VT 30					
Tramlining control	Automatic management 2 x 2 rows					
Electronic monitoring	Seed level - metering unit rotation					
Counters	Daily and total					
Distribution half-width shut-off	◆ Left side					
Approx. weight (kg)	920	950	1010	1050	1015	1100
Loading platform	◆					
Parking stands	◆					

◆ standard ◇ as option - not available

Optional equipment: VT 30 terminal, ISOBUS CCI 50 terminal, ISOBUS CCI 1200 terminal, hopper extension, pre-emergence markers, SEEDFLEX roller scraper, disc outer scraper, LED work lights.

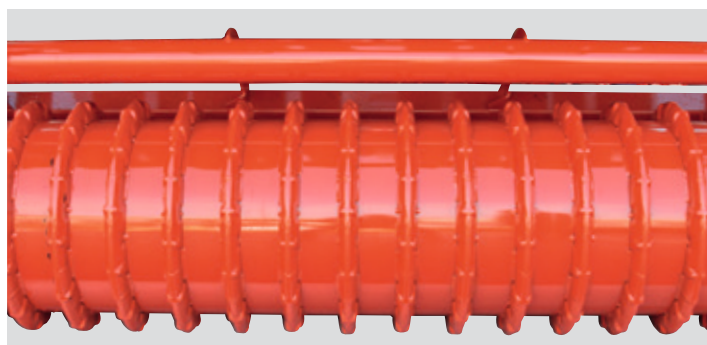

STEELLINER ROLLER:

- large diameter of 550 mm,
- very good rolling and carrying capacity,
- improved crumbling capacity on dry and hard soils,
- good soil structure even in difficult and wet conditions.

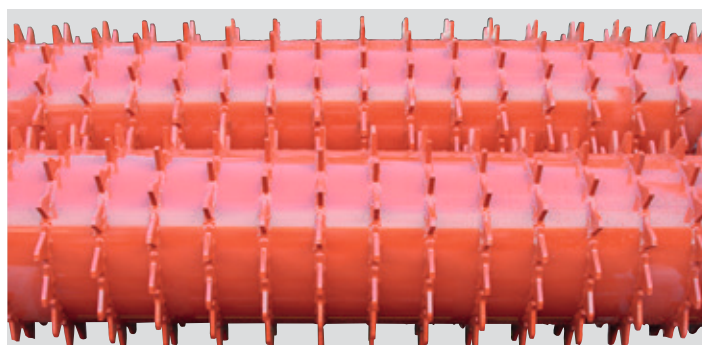

MEGAPACKER ROLLER:

- large diameter of 590 mm,
- easy to pull on light soils,
- excellent soil compaction.

Specifications

		CD 3020	HR 3020
Type of tool		Integrated cultivator with notched discs	
Working width approx. (m)		3.00	3.00
Transport width (m)		3.00	3.00
Max. tractor power (kW/hp)		162 / 220	132 / 180
Min. tractor power (kW/hp)		96 / 130	59 / 80
Tractor hydraulic requirement		-	
Gearbox		-	
Safety		-	
PTO speed (min ⁻¹)		-	
Rotor speed (min ⁻¹)		-	
Number of rotors or discs		24	10
Number of disc rows		2	
Distance between disc rows		490	
Disc dimensions (mm)		Diameter: 400 - Thickness: 5	
FAST-FIT blade attachment		-	
Working depth adjustment		Manual	◆ Manual ; ◇ Hydraulic
Levelling bar adjustment		-	◆ Manual ; ◇ Hydraulic
Side deflectors		On parallelogram	
Linkage		Cat. 2, 3N, 3	
Weight approx. (kg)	with MEGAPACKER roller (590 mm)	1,351	1,611
	with MAXIPACKER roller (535 mm)	1,309	1,569
	with 12.5 cm PACKLINER roller (592 mm)	-	1,685
	with 15 cm PACKLINER roller (590 mm)	-	1,672
	with 12.5 cm STEELLINER roller (550 mm)	1,400	1,659
	with 15 cm STEELLINER roller (550 mm)	1,366	1,625

◆ standard ◇ optional - not available

Optional equipment: Hydraulic adjustment of working depth and levelling bar on HR 1020 and 1030 models.

KUHN SERVICES* Maximise the use and productivity of your KUHN equipment

*Not all services and equipment are available in every country.

KUHN sos order

EXPRESS SPARE PARTS SERVICE 24/7

You urgently need spare parts? With KUHN SOS order benefit from express delivery seven days a week, 365 days a year. Thus, you can minimise machine downtime considerably and increase your work output.

KUHN protect +

THE CHOICE OF PROFESSIONALS!

Benefit from 36 months in complete serenity because of KUHN's protect + warranty. You can concentrate exclusively on your work and the performance of your machine. Because this is what you expect, when investing in high-tech machinery.

KUHN i tech

FOR EVER QUICKER REPAIRS!

An unexpected technical problem always occurs at the wrong time. Your KUHN dealer can support you quickly and efficiently thanks to KUHN i tech. With this 24/7 online service, a quick and exact diagnosis is possible.

KUHN finance

INVEST RATIONALLY!

New machine necessary, financing unsure? Modernise your equipment and develop your farm with KUHN finance, in total safety and according to your needs and demands. We offer custom-made finance solutions, adapted to your requirements.

HR 3030	HR 3040
Active power harrow drive	
3.00	3.00
3.00	3.00
176 / 240	219 / 300
59 / 80	66 / 90
◇	2 x DA (levelling bar, depth adjustment)
Duplex	Duplex with oil circulation
Cut-out clutch	
1,000	
290 - 330 (after inversion)	296 - 463 (after inversion)
10	10
-	-
-	-
-	-
◆	-
◆ Manual ; ◇ Hydraulic	◆ Hydraulic
◆ Manual ; ◇ Hydraulic	◆ Hydraulic
Adjustable - spring safety and double arm	
Cat. 2, 3, 4N with yokes	
1,721	1,910
1,679	1,865
1,795	1,980
1,782	1,970
1,769	1,955
1,735	1,920



be strong, be **KUHN**

KUHN PARTS

Designed and manufactured to rival time



KUHN foundries and forge as well as a high-level manufacturing process allow the production of spare parts to defy time. You can truly rely on our know-how and our genuine parts. Farmers benefit from our client support and logistics services via any KUHN PARTS warehouse, which provide quick and reliable repair solutions in cooperation with your nearest authorised KUHN dealer.



CD

HR

SITERA

MOBILE APPLICATION



SEEDSET: OPTIMISE YOUR SEED DRILL SETTINGS.

KUHN has developed a calibration assistant to help you determine the right settings for your seed drill and seeding conditions (seed type, quantity, etc.). This smartphone app also provides you with a seeds/m² to kg/ha converter.

You don't have it yet?

Download the application on the Apple Store and Google Play.



Check out the most complete range of seed drills on the market.



1. mounted mechanical - 2. integrated mechanical - 3. with front hopper - 4. integrated pneumatic - 5. mounted seeding combination
6. mounted min-till - 7. trailed min-till - 8. precision seed drills

For more information about your nearest KUHN dealer, visit our website www.kuhn.com



Visit us on our YouTube channels.



www.kuhn.com

Your KUHN dealer

KUHN S.A.

4 Impasse des Fabriques - BP 50060
F-67706 Saverne CEDEX - FRANCE

KUHN NORTH AMERICA, INC.

1501 West Seventh Avenue - Brodhead,
WI 53520 - USA

KUHN FARM MACHINERY PTY. LTD

313-325 Foleys Road - Deer Park, VIC, 3023 - AUSTRALIA

KUHN FARM MACHINERY (U.K.) LTD

Stafford Park 7 - GB TELFORD/ SHROPS TF3 3BQ

Information given in this document is only for information purposes and is non-contractual. Our machines are in compliance with regulations in force in the country of delivery. In our literature, and for improved illustration of certain details, some safety devices may not be in operating position. When operating these machines, these devices must be in position in accordance with the requirements indicated in the operator's manuals and assembly manuals. Respect the tractor gross vehicle weight rating, its lift capacity and maximum load per axle and tyres. The tractor front axle load must always comply with the regulations of the country of delivery (In Europe, it must reach minimum 20 % of the tractor net weight). We reserve the right to change any designs, specifications or materials listed without further notice. Machines and equipment in this document can be covered by at least one patent and/or registered design. Trademarks cited in this document may be registered in one or several countries.

Also find KUHN on  