



DRS-SERIES SCRAP SHEARS

DEMAREC. SMART CHOICE.

Meet the most important demands of the clients. The DEMAREC DRS Scrap Shear with its 360° rotation was engineered to deliver a scrap shear with a maximum force, highest speed and optimal weight to performance ratio in daily use in scrap yards and demolition sites. This robust tool can be used for a wide variety of jobs including demolition, scrap processing and tire recycling. With three different mounting options, the DRS line is available in six different sizes, suitable for excavators from 14t to 100t operating weight.

- ☑ Extremely high cutting force and optimal performance to weight ratio.
- ☑ Powerful cylinder with speed valve – fully protected in the shear body.
- ☑ More cutting force due to offset APEX of shear blades.
- ☑ Body made of wear resistant, fine grained steel.
- ☑ Heavy duty bearings in the pivot points for a long lifetime.
- ☑ Unique, extremely robust Shear Arm Guiding System (SGS).
- ☑ Robust mouth design with large opening for scrap and concrete.
- ☑ Exchangeable and re-weldable piercing tip.
- ☑ All blades are 4 or 8 times indexable.
- ☑ Unique Blade Locking System (BLS) in upper and lower jaw.
- ☑ Heavy duty 360° rotation with oversized slewing ring.
(shear also available without rotation).
- ☑ Filter in rotation circuit.
- ☑ Optional: Different airbrush designs.







DR Shear Arm

- ☑ **Massive shear arm** made of Hardox steel for a long lifetime
- ☑ **Heavy duty slim shear arm design** guarantees an optimum penetration



DR Bearings

- ☑ **Generously dimensioned and free of play adjustable shear arm and cylinder bearings** reduce the wear of pins and bearings and jaw drive
- ☑ **Induction-hardened pins** are seated in the bearings
- ☑ **Hardened lateral guide plates** provide the support of the shear arm within the main frame for a longer lifetime (Shear Arm Guide System)



DR Mouth Design / Cutting Blades

- ☑ **Optimal mouth design** with large opening
- ☑ **More cutting capacity** due to offset APEX of shear blades
- ☑ **Four-way indexing blades** provide longer life span
- ☑ **Piercing tip** is exchangeable and re-weldable
- ☑ **All blades** can be released from the outside
- ☑ **Blade Locking System (BLS)** in upper and lower jaw



DR Performance to Weight Ratio

- ☑ **Endurance tests** as well as **FEM stress calculations** confirm the **weight optimized design** and provide an ideal weight / power ratio

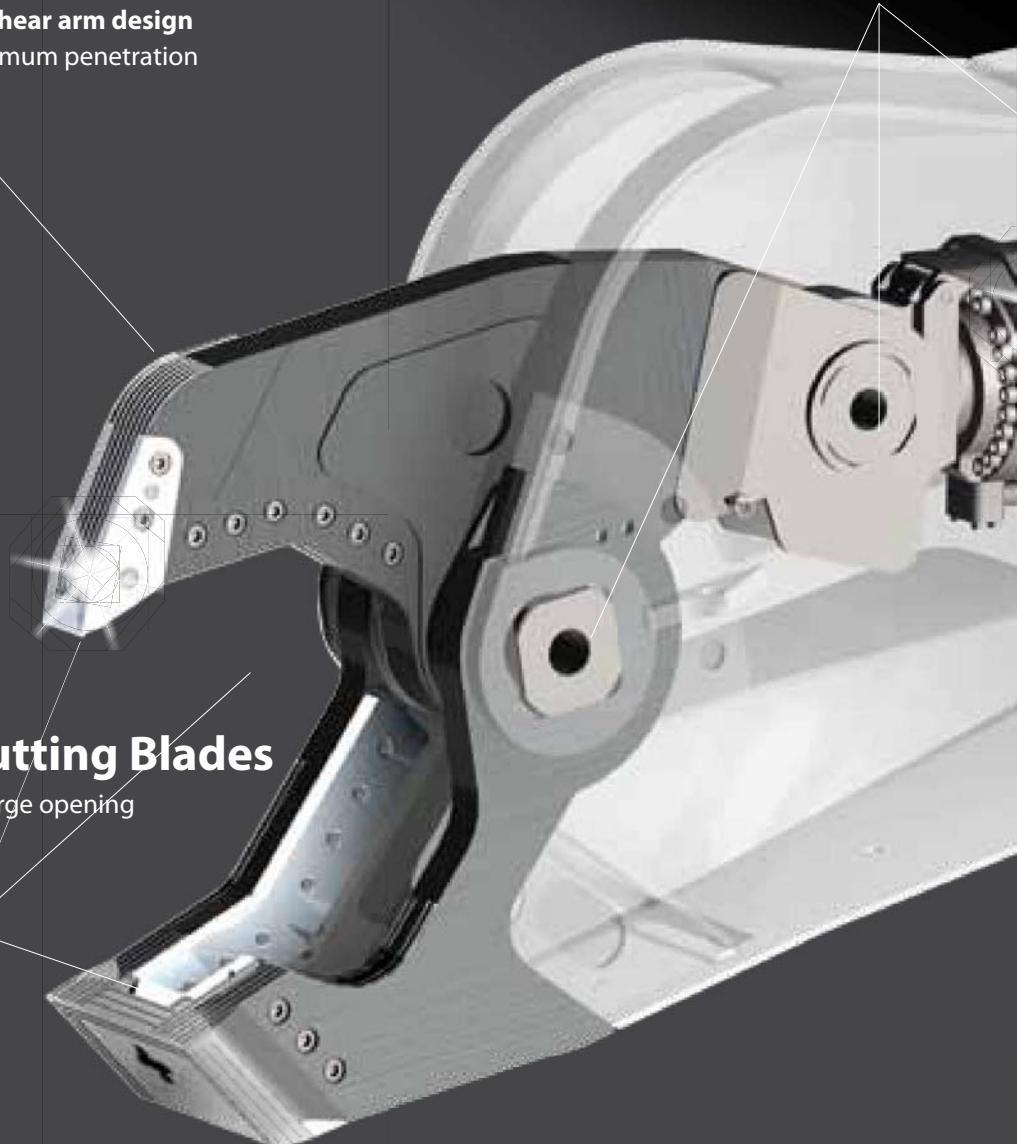

lay
ring minimize
distortion
steel bearings
a stable
n bearing
ystem SGS)



Heavy Duty Rotation

- ☑ **360° continuous rotation**
(shear also available without rotation)
- ☑ **Oversized slewing ring** is able to bear high forces, shock loads and bending moments
- ☑ **Filter in rotation circuit**
- ☑ **Heavy duty motors** for a maximum rotation torque

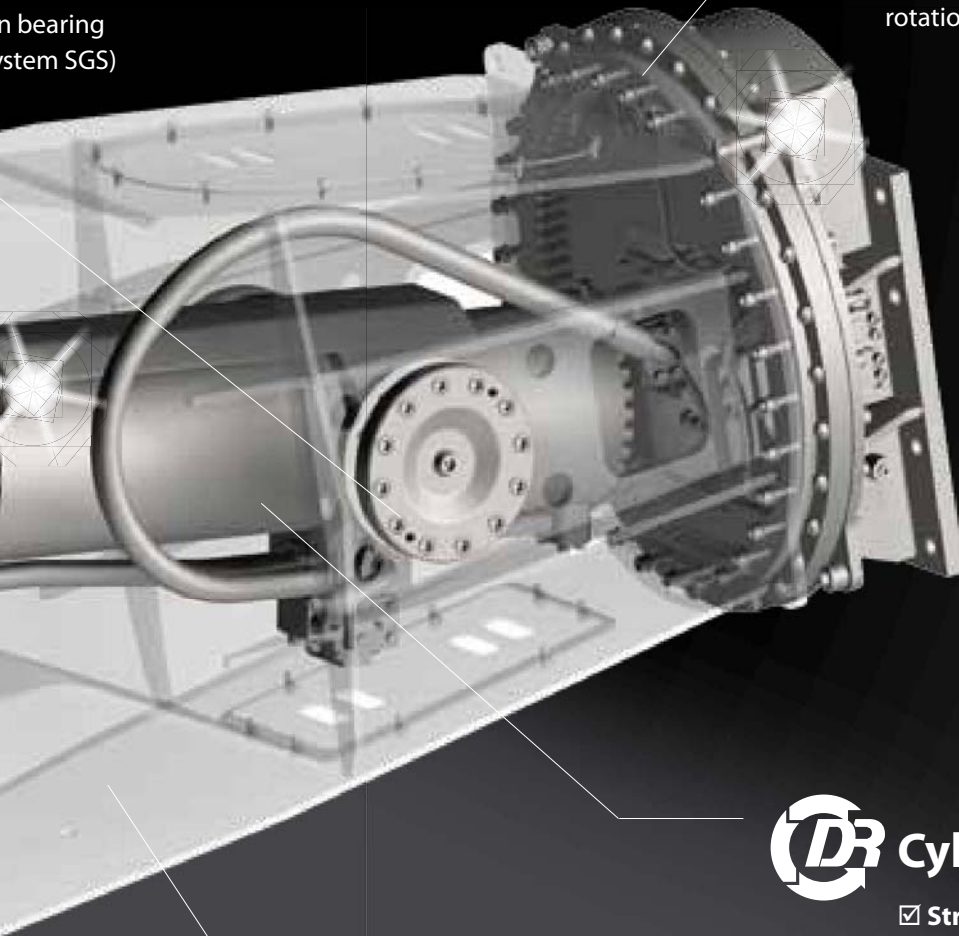

Cylinder / Hydraulics

- ☑ **Strong long-stroke cylinder** with speed valve
- ☑ **Trunnion design of the hydraulic cylinder** results in an overall shorter shear length
- ☑ **Center of gravity closer** to the machine adds to higher stability
- ☑ **Cylinder completely protected** within the body
- ☑ **High pressure hoses** withstand pressure spikes
- ☑ **High capacity swivel** helps to avoid high oil temperature and to ensure high oil flow / speed



Shear Body

- ☑ **Strong box design** made of high-strength fine grained steel. The shear body ensures highest strength
- ☑ **Fast access** to hoses and hydraulics through service openings
- ☑ **No protruding components.**
Minimizes the chance of downtime



DEMAREC: Maximum Support

For the DEMAREC range there is a comprehensive manufacturer service program for the period of the shear's service life. Based on customer demand. It is founded on quality, availability and service:

- ☑ DRS scrap shears are designed to reduce service and be maintenance friendly.
- ☑ Maximum availability of all our products – including wear parts to ensure minimal downtime and optimal performance.
- ☑ General maintenance and reconditioning by our customer service department.
- ☑ Development of individual service concepts for each user.
- ☑ Dealers world-wide are trained each year (sales training and service training) in order to have all up to date information. Our own intranet system provides a direct link between our dealers and DEMAREC.



Example of lower costs of ownership:
Up to 4 or 8 times reusable cutting blades

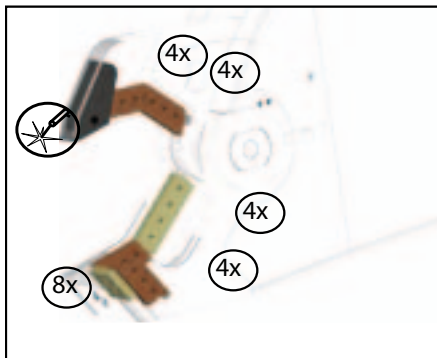

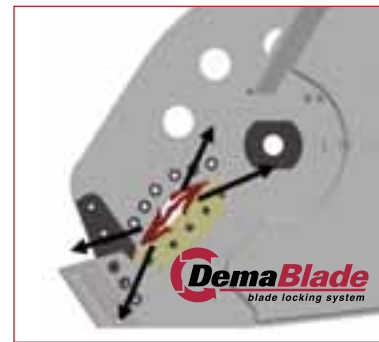
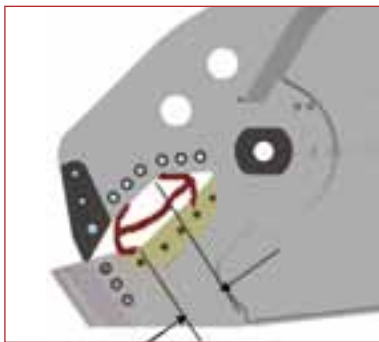
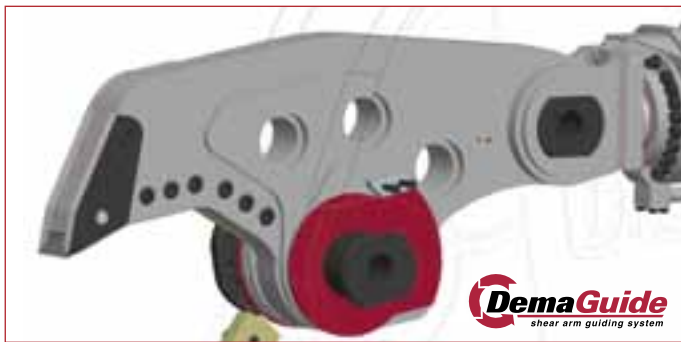

Jaw is fully guided by hardened shims. Unique, extremely robust Shear Arm Guiding System (SGS) – easy to maintain

Offset APEX: Steel is compressed and molded in the mouth and thus easier to cut

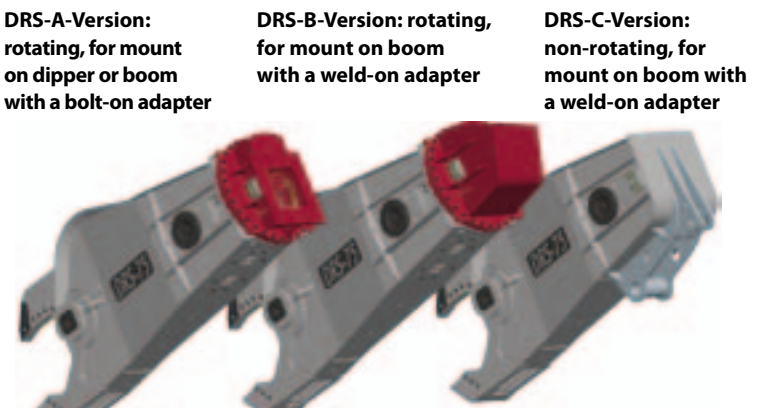
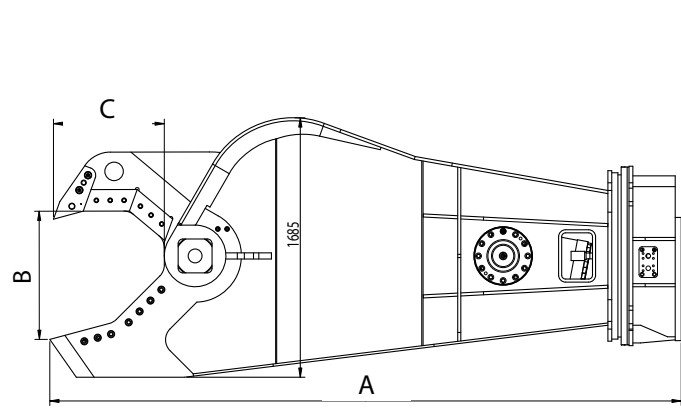

Technical Data / Dedicated Shears with 360° Rotation or rigid mount (without Rotation)

Type	Weight * (kg)	Length A * (mm)	Jaw opening B (mm)	Jaw depth C (mm)	Primary cutter length (mm)	Cutting force** (kN)	Operating weight [boom] (t)	Operating weight [dipper] (t)
DRS-25-A	2100	2740	500	460	180/280	4975	14-20	20-30
DRS-30-A	3100	2965	570	490	200/300	6700	18-25	25-35
DRS-45-A	4100	3290	625	540	225/330	8210	25-35	32-50
DRS-60-A	5350	3660	720	620	250/380	10990	30-45	45-65
DRS-60-B	5450	4100	720	620	250/380	10990	30-45	-
DRS-75-A	6800	4075	835	720	300/440	14270	35-60	60-80
DRS-75-B	6900	4550	835	720	300/440	14270	35-60	-
DRS-75-C	6000	3650	835	720	300/440	14270	30-50	-
DRS-90-A	8500	4800	950	800	350/480	20500	45-75	75-100
DRS-90-B	8600	5000	950	800	350/480	20500	45-75	-
DRS-90-C	7600	4100	950	800	350/480	20500	40-70	-

*excl. adapter **cutting force calculated at a distance of 120 mm (DRS-25) / of 140 mm (DRS-30) / of 160 mm (DRS-45 to DRS-90) from centre of pin

Hydraulics

Type	Opening/ Closing		Rotation		Back pressure max. (bar)	Working cycle Opening/ Closing (sec)
	Pressure max. (bar/psi)	Flow (l/min)	Pressure max. (bar)	Flow (l/min)		
DRS-25	380	150-250	140	60	-	2,4 / 2,3
DRS-30	380	200-300	140	60	-	2,9 / 3,0
DRS-45	380	300-400	140	60	-	3,7 / 2,2
DRS-60	380	400-600	200	60	10 (drain line required)	3,0 / 2,2
DRS-75	380	600-800	200	60	10 (drain line required)	3,0 / 2,5
DRS-90	380	700-1000	200	80	10 (drain line required)	3,5 / 2,5

Cutting Performance

Steel Profiles	DRS-25	DRS-30	DRS-45	DRS-60	DRS-75	DRS-90	
H-beams							
light	HEA 280	HEA 340	HEA 400	HEA 500	HEA 600	HEA 700	
normal	HEB 200	HEB 260	HEB 300	HEB 360	HEB 400	HEB 450	
heavy	HEM 100	HEM 140	HEM 160	HEM 180	HEM 200	HEM 220	
I-beams							
light	IPE 450	IPE 500	IPE 600	IPE 700	IPE 800	IPE 900	
normal	INP 320	INP 400	INP 450	INP 500	INP 550	INP 600	
L-angles	(mm)	200x200x15	250x250x20	250x250x25	300x300x25	300x300x30	350x350x30
solid round	(mm)	75	90	100	115	130	150
solid square	(mm)	65	80	90	100	120	135
piercing plate	(mm)	15	20	25	25	30	35
pipe x wall	(mm)	254 x 9	304x10	406x10	457x10	559x10	609x10

This chart gives an indication of the cutting capacity of the DRS Shears based on the assumption of a working pressure of 350 bar, normal steel profiles with a tensile strength of maximum 370 N/mm², and a good condition of the blades. The DRS Shear divides larger profiles in two cuts as long the web thickness does not exceed the maximum thickness of the piercing plate.





DEMAREC SMART CHOICE is the logic of a strong brand. It consolidates our commitment to our products ensuring mature and ground-breaking technologies that guarantee user efficiency, stability, strength, speed and serviceability.

SMART CHOICE – DEMAREC highlights the commitment of the **KINSHOFER Group** to the demolition and recycling market as well as to **QUALITY** itself.

DEMAREC is specialist for scrap yard and demolition business with more than 25 years experience in developing and manufacturing. In 2006, **DEMAREC** became member of the **KINSHOFER** group.

For the user of the DRS-Products **KINSHOFER** offers also heavy duty polyp grapples to complement our program.

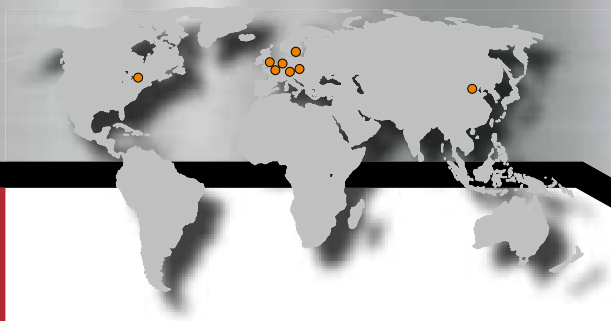

Trendsetter in Demolition and Recycling Equipment

DEMAREC Demolition and Recycling Equipment B.V.
Den Hoek 10
NL-5845 EL St. Anthonis
The Netherlands
Tel.: +31 (0)485 442300
Fax: +31 (0)485 442120
info@demarec.com
www.demarec.com

KINSHOFER GmbH
Hauptstrasse 76
DE-83666 Waakirchen
Tel.: +49 (0)8021 – 88 99 0
Fax: +49 (0)8021 – 88 99 37
info@kinshofer.com
www.kinshofer.com

KINSHOFER UK Ltd.
4 Milton Industrial Court
Horsfield Way, Bredbury
Stockport, Cheshire, GB - SK6 2TA
Tel.: +44 (0)161 – 406 7046
Fax: +44 (0)161 – 406 7014
sales@kinshofer.co.uk
www.kinshofer.com

KINSHOFER North America
5040 Mainway Drive, Unit #11
Burlington, ON L7L 7G5 Canada
Tel.: +1 (905) 335 2856
Fax: +1 (905) 335 4529
Toll Free (NA): 1-800-268 9525
sales-northamerica@kinshofer.com
www.kinshofer.com

KINSHOFER France S.A.R.L.
B.P. 20100
FR-67213 Obernai Cedex
Tel.: +33(0) 3 88 39 55 00
Fax: +33(0) 3 88 79 06 75
info@kinshofer.fr
www.kinshofer.com

Darda KINSHOFER
Construction Machinery Co. Ltd.
Unit #306, Landmark Tower 2
8 Dongsanhuan Road
Beijing 100004
P.R. of China
Tel.: +86 (10) 6590 6422
Fax: +86 (10) 6590 6423
info@darda.com.cn
www.darda.com.cn

KINSHOFER Aponox Oy
Terminaalitie 10
FI-13430 Hämeenlinna
Tel.: +358 (0)75 7540 200
Fax: +358 (0)75 7540 210
info@kinshofer-aponox.com
www.kinshofer-aponox.com

KINSHOFER Sales in Russia:
Nikolai Voronov
Tel.: +7 (911) 720 10 60
n.voronov@kinshofer.com
www.kinshofer.com

RF System AB
Furutorpsgatan 6
SE-288 32 Vinslöv
Tel.: +46 (0)44 817 07
Fax: +46 (0)44 859 63
info@rf-system.se
www.rf-system.se