



# SCC900A

## SANY Crawler Crane

### 90 Tons Lifting Capacity

Quality Changes the World





Crawler Crane Series  
**SCC900A**

P03	Main Characteristics	<ul style="list-style-type: none"><li>▪ Driver's cab</li><li>▪ Upperworks</li><li>▪ Lowerworks</li><li>▪ Operating Equipment</li><li>▪ Safety Device</li></ul>
P09	Technical Parameters	<ul style="list-style-type: none"><li>▪ Major Performance &amp; Specifications</li><li>▪ Outline Dimension</li><li>▪ Transport Dimension</li><li>▪ Transport Plan</li></ul>
P17	Combination of Working Conditions	<ul style="list-style-type: none"><li>▪ H Configuration</li><li>▪ FJ Configuration</li></ul>



## **SCC900A** **SANY CRAWLER CRANE** **90 TONS LIFTING CAPACITY**

QUALITY CHANGES THE WORLD

### Main Characteristics

- Page 04 Driver's cab
- Page 05 Upperworks
- Page 06 Lowerworks
- Page 06 Operating Equipment
- Page 07 Safety Device

## Operator's cab



### Operating Comfort

- Fully-enclosed steel frame structure is adopted, and the front, side, and the top of the cab are installed with large high-strength tempered glass, which admits sufficient light. The operator's cab is bright with ample space, providing wider view and isolates noise in a better way. Multimode and multilevel adjustable suspension seat is mounted with minimum vibration and noise, bringing the most comfortable driving experience for the operator. Air conditioning and heater are designed to ensure the perfect temperature for operator. Better man-machine interactive interface are realized through integrated 10.4-inch touch screen, programmable key switch and vibrating handle. On the left console mounted swing control handle, control buttons, emergent stop, radio and A/C panel; on the right console mounted three independent one-axis handles controlling winches, and two one-axis travel handles, as well as ignition, engine throttle and winch speed buttons. The total layout is more human-friendly.

### Closed Circuit Monitoring System

- The screen can mostly present four pictures on one page, showing the wire rope reeving on each winch, surroundings behind counterweight and environment around the machine.

## Upperworks



### Engine

- Model: Isuzu 6HK1 (Tier III);
- Rated power 212 Kw/2000rpm;
- Total displacement: 7.79L;
- Max. torque 1080 N·m /1500rpm.

### Electrical Control System

- SYIC-2 integrated control system independently developed is adopted to ensure high system integration and accurate operation. The control system mainly includes power system, engine system, master control system, LMI system, auxiliary system, and safety monitoring system. Main electrical components are from internationally or industrially well-known brands with reliable quality, which can perform stably in such bad environment as in severe low or high temperature, plateau, and sandstorms;
- The controller, monitor and the engine communicates through CAN Bus.

### Hydraulic System

- The main pump is piston pump with variable displacement, and winch motors are piston motor of limitless adjustable displacement, providing higher operation speed. The hydraulic system can save more energy and boost efficiency while maintaining the stability and reliability;
- Increase efficiency of load hoisting and other multi-functions. Inching performance of all actions is excellent;
- Strong heat exchange of hydraulic system is designed to improve heat balance and better coping with the climate.

### Swing Mechanism

- Internal-mesh swing drive can swing the upperworks by 360°;
- Swing lock: Swing lock device is installed. When the operation is over or the machine is in transport, the upperworks can be locked tightly;
- Swing bearing: single row ball bearing;
- Swing speed: 0-2.5rpm.

### Main and Aux. Load Hoist Mechanism

- Main and aux. hoist winches are driven separately by motor via gearbox. Operating winch handle can control the winch to rotate to two directions, which are lifting and lowering of hook. Excellent inching function is equipped on the machine;
- Drums with fold-line grooves can ensure the wire rope reeved in order in multilayers.

Main Load Hoist Mechanism	Drum diameter	630mm
	Single rope speed	0~130m/min
	Wire rope diameter	26mm
	Wire rope length of main load hoist	240m
	Rated single line pull	12t
Auxiliary Load Hoist Mechanism	Drum diameter	630mm
	Single rope speed	0~130m/min
	Wire rope diameter	26mm
	Wire rope length of auxiliary load hoist	180m
	Rated single line pull	12t

### Boom Hoist Mechanism

- Boom hoist winches are driven separately by motor via gearbox. Operating winch handle can control the winch to rotate to two directions, which are lifting and lowering of boom;
- Drums with fold-line grooves can ensure the wire rope reeved in order in multilayers.

Boom hoist mechanism	Drum diameter	400mm
	Single rope speed	0~70m/min
	Wire rope diameter	20mm
	Wire rope length of boom hoist	140m
	Rated single line pull	7t

### Counterweight

- Counterweight tray and blocks are piled up for easier assembly and transport;
- Rear counterweight: total 30.3t;
- Standard counterweight: tray for non-self-assembly mode 8.26t×1, left counterweight block 3.68t×3, right counterweight block 3.68t×3;
- Carbody counterweight: 3t×2 at the front and rear of carbody.

## Lowerworks

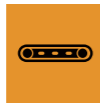

- Independent travel driving units are adopted for each side of the crawler, to realize straight walking and turning driven by travel motor through gearbox and drive wheel.

### Crawler Extension and Retraction

- The crawlers can extend and retract via cylinders. During Work Mode, the crawlers must be extended, and retracted during transport with crawlers on.

### Crawler Tensioning

- The jack is used to push the guide wheel and insert the shim to adjust crawler tension.

### Track Shoes

- High-strength alloy cast steel track pad can prolong the service life. They are 850mm wide, and the total amount is 52pcs x 2.

### Outrigger

- Outrigger cylinder is offered as optional to facilitate the track frame disassembly during jobsite transfer.

## Operating Equipment



- All chords are high-strength steel tubes, and the boom/jib top sheaves are made of high-strength anti-wearing Nylon material protecting wire rope. The hooks are installed with milled welded steel sheave. Pendant cables with quick hitch connector that are easy to assemble are offered as options.

### Boom

- Lattice structure. The chord adopts high-strength structural tube and each section is connected through pins.
- Basic boom: 6.5m boom top + 6.5m boom base;
- Boom insert: 3m×2, 6m×1, 9m×4;
- Boom length: 13m~61m.

### Fixed Jib

- Lattice structure. The chord adopts high-strength structural tube and each section is connected through pins;
- Basic boom: 4.5m boom top + 4.5m boom base;
- Boom insert: 4.5m x 2;
- Boom length: 9m~18m;
- Longest boom + jib: 52m boom +18m jib.

### Extension Jib

- The extension jib is a welded structure connected to the boom tip by pins, used for auxiliary hook;
- Extension jib length: 1.2m.

### Hook Block

- 100t hook block, five sheaves;
- 50t hook block, three sheaves;
- 25t hook block, one sheave;
- 13.50t ball hook.



## Safety Device

### Assembly Mode/Work Mode Switch

- In Assembly Mode, certain safety devices are disabled to facilitate crane assembly;
- In Work Mode, all safety devices activate to protect the operation.

### Emergent Stop

- In emergent situation, this button is pressed down to cut off the power supply of the whole machine and all actions stop.

### Load Moment Indicator (LMI)

- It is an independent computerized safety control system. LMI can automatically detect the load weight, work radius and boom angle, and present on the display the rated load, actual load, work radius and boom angle. In normal operation, the LMI can make a judgment and cut off automatically if the crane moves towards dangerous direction. It can also perform as a black box to record the lifting information.
- It is composed of monitor, angle sensor, force sensor and other parts.

### Over-hoist Protection of the Main/ Auxiliary Load Hoist

- Over-hoist protection device comprises limit switch and weight on boom top, which prevents the hook lifting up too much. When the hook lifts up to the limit height, the limit switch activates, buzzer on the left control panel sends alarm, failure indicator light starts to flash and the hook hoisting action is cut off automatically.

### Over-release Protection Device of the Main/Auxiliary Load Hoist

- It is comprised of activator in the drum and proximity switch to prevent over release of wire rope. When the rope is paid out close to the last three wraps, the proximity switch acts, and the system sends alarm through buzzer and show the alarm on the monitor panel, automatically cutting off the winch action.

### Function Lock

- If the function lock level is not in work position, all the other handles won't work, which prevents any mis-operation caused by accidental collision.

### Boom hoist drum lock

- Hydraulically controlled lock is installed for boom hoist drum, which needs to unlock by switch before operation, in order to prevent mis-operation of handles and ensure safety during non-work time.

### Swing Lock

- Swing Lock can lock the machine at four positions, front and back, left and right.

### Boom Limit Device

- When the boom elevation angle is over the limit, the buzzer sounds and boom action is cut off. This protection is two-stage control ensured by both LMI system and travel switch.

### Back-stop Device

- Its major components are nesting tubes and spring, in order to buffer the boom backlash and prevent further tipping back.

### Boom Angle Indicator

- Pendulum angle indicator is fixed on the side of boom base close to the cab, so as to provide convenience to the operator.

### Hook Latch

- The lifting hook is installed with a baffle plate to prevent wire rope from falling off.

## Safety Device



### Monitoring System

- Remote Monitoring system is a standardized offering to provide functions like GPS locating, GPRS data transfer, machine status inquiry and statistics, operating data monitoring and analysis, remote diagnosis of failures.

### Tri-color Load Indicator

- The load indication light has three colors, green, yellow and red, and the real time load status is presented on the display. When the actual load is smaller than 90% of rated load, the green light is on; when the actual load is larger than 90% and smaller than 100%, the yellow light is on, the alarm light flashes and sends out intermittent sirens; when the actual load reaches 100% of rated load, the red light on, the alarm light flashes and sends out continuous sirens. At this moment, the system will automatically cut off the crane's dangerous operation.

### Alarm Light

- When the machine is powered on, the alarm light will work when time comes, so as to warn people around.

### Swing Indicator Light

- The swing indicator light flashes during traveling or swing.

### Illuminating Light

- The machine is equipped with, short-beam light in front of machine, front angle adjustable far-beam, lamps in operator's cab, lighting devices for night operation, so as to increase the visibility during work.

### Rearview Mirror

- It is installed on the left of the operator's cab and at the front handrail of the sheet metal for monitoring the rear part of the machine.

### Pharos

- Pharos is mounted on the top of boom/jib to indicate the height.

### Anemometer

- It is mounted on the top of boom/jib, and displayed on the monitor in the cab.

### Electronic Level Gauge

- It displays the tipping angle of crane on the monitor in real time, and sends out alarm automatically when the angle is out of limit, so as to warn the operator.

### Operation Release

- If the operator leaves the seat, all control handles will be locked immediately to prevent any mis-operation due to accidental collision.

### Engine Power Limit Load Adjustment and Stalling Protection

- The controller monitors the engine power to prevent engine getting stuck and stalling.

### Engine Status Monitoring

- The engine status will be presented, such as engine coolant temperature, fuel volume, total work hours, engine oil pressure, engine speed, battery charging, voltage.



## SCC900A SANY CRAWLER CRANE 90 TONS LIFTING CAPACITY

QUALITY CHANGES THE WORLD

## Technical Parameters

- Page 10 Major Performance & Specifications
- Page 11 Outline Dimension
- Page 12 Transport Dimension
- Page 16 Transport Plan



Major Performance & Specifications

Major Performance & Specifications of SCC900A			
Performance Indicators		Unit	Parameter
Configuration	Max. rated lifting capacity	t	90
	Boom length	m	13~61
	Boom luffing angle	°	30~80
FJ	Max. rated lifting capacity	t	11
	Jib length	m	9~18
	Longest boom + jib	m	52+18
	Jib angle	°	15, 30
Speed	Rope speed of main/aux. winch (1st layer)	m/min	0~130
	Rope speed of boom hoist winch (3rd layer)	m/min	0~70
	Swing speed	rpm	0~2.5
	Travel speed	km/h	0~1.5
Wire rope	Main load hoist wire rope: diameter × length	φ mm×m	26×240
	Aux. load hoist wire rope: diameter × length	φ mm×m	26×180
	Rated single line pull of main/aux. hoist wire rope	t	12
Engine	Model/Displacement	/L	6HK1/7.79
	Rated power/revolution speed	kW/ rpm	212/2000
Transport	Weight of basic boom	t	85.5
	Rear counterweight	t	30.3
	Carbody counterweight	t	3.0×2
	Transport weight of basic machine (with crawler frame and boom base)	t	46.5
	Transport weight of basic machine (without crawler frame)	t	28.1
	Machine transport dimension (with crawlers and boom base) L×W×H	mm	13300×3490×3450
Machine transport dimension (without crawlers and boom base) L×W×H	mm	8450×3000×3050	
Other specifications	Average ground pressure (basic boom)	MPa	0.085
	Gradeability	%	30

Outline Dimension

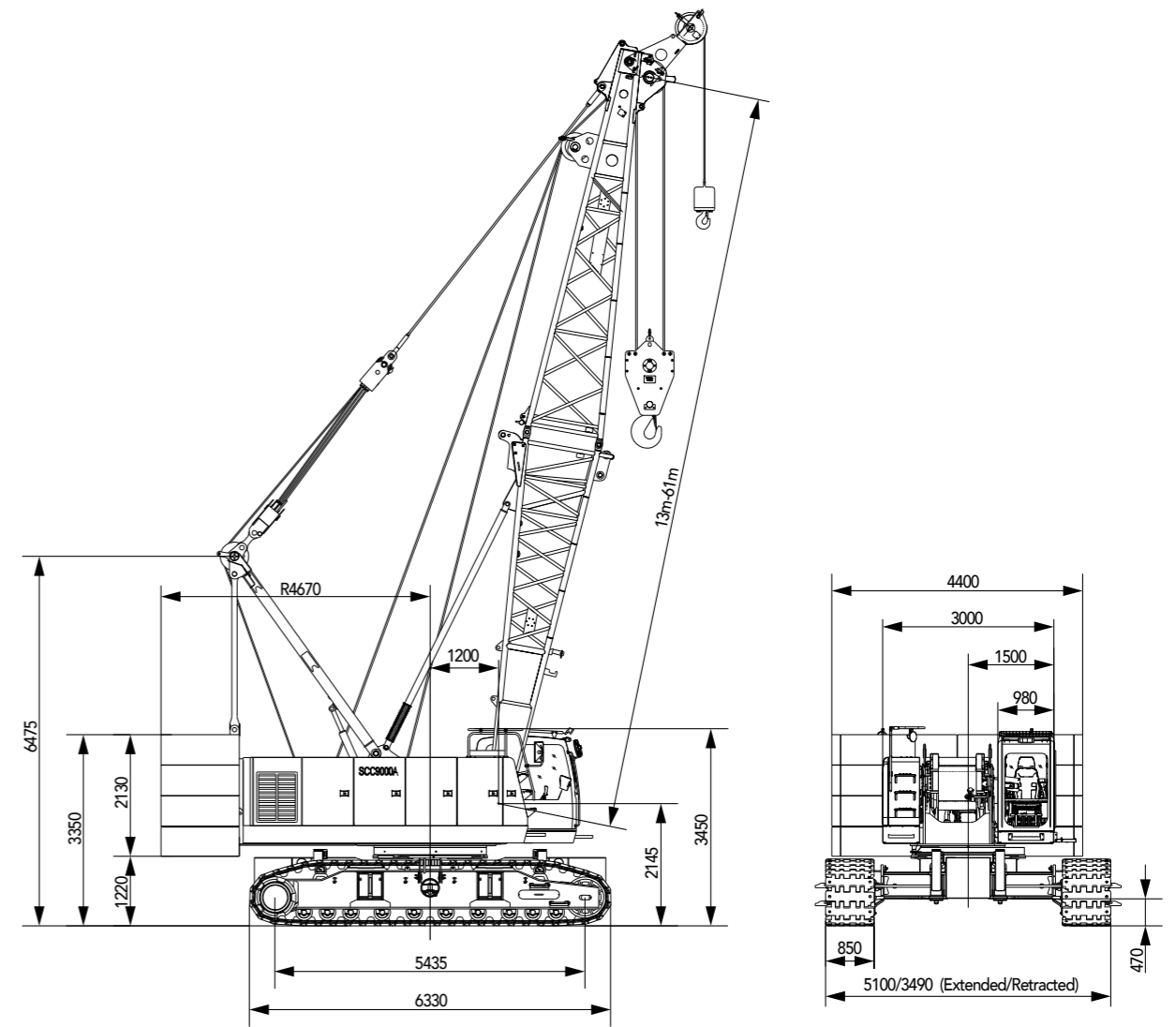

## Transport Dimension

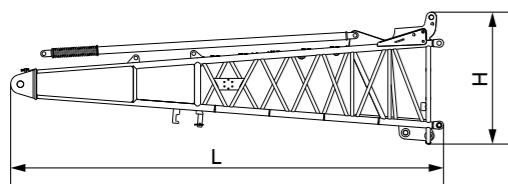
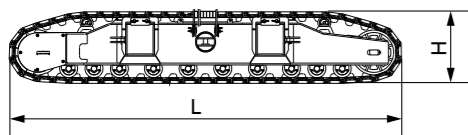
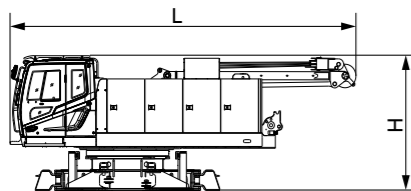
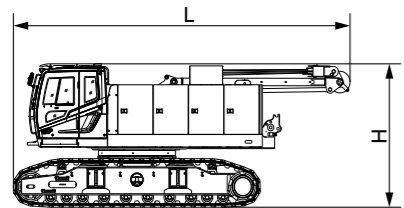
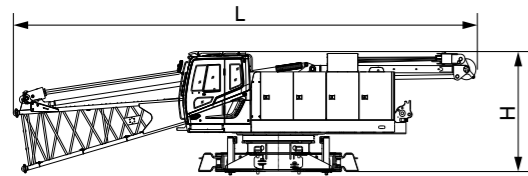
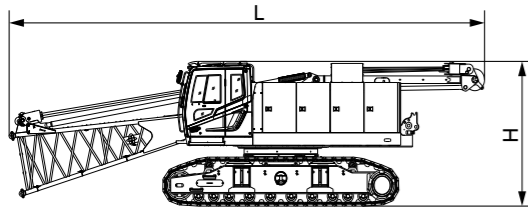
**Basic Machine 1 (with boom base, crawler frames)** ×1

Length(L)	13.3m
Width(W)	3.49m
Height(H)	3.46m
Weight	46.5t

**Basic Machine 2 (with boom base)** ×1

Length(L)	13.3m
Width(W)	3.00m
Height(H)	3.07m
Weight	28.1t

Note: this includes optional outriggers.

**Basic Machine 3 (with crawler frames)** ×1

Length(L)	8.67m
Width(W)	3.49m
Height(H)	3.46m
Weight	44.6t

**Basic Machine 4** ×1

Length(L)	8.31m
Width(W)	3.00m
Height(H)	3.07m
Weight	26.2t

Note: this includes optional outriggers.

**Crawler frame** ×2

Length(L)	6.33m
Width(W)	1.09m
Height(H)	1.15m
Weight	9.2t

**Boom base** ×1

Length(L)	6.72m
Width(W)	1.78m
Height(H)	2.06m
Weight	1.90t

## Transport Dimension

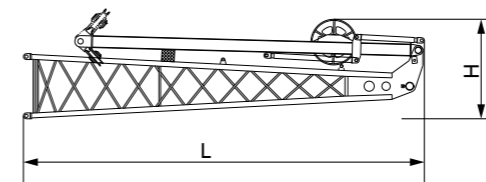
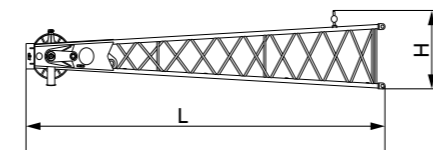
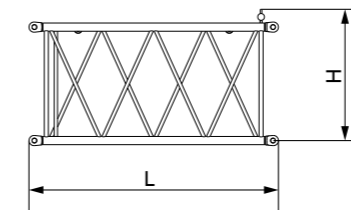
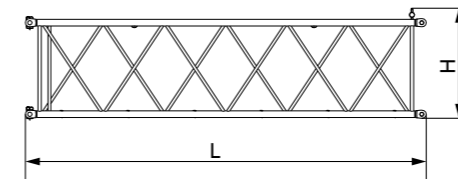
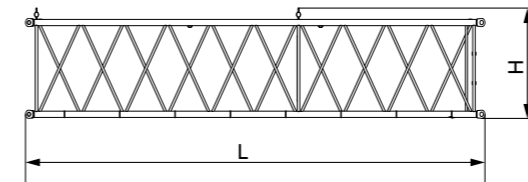
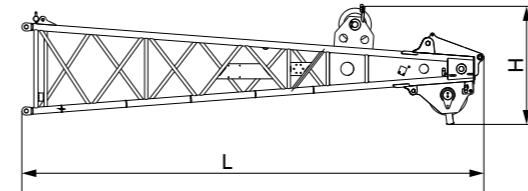
**Boom top** ×1

Length(L)	7.13m
Width(W)	1.49m
Height(H)	1.79m
Weight	1.35t

**9m boom insert** ×4

Length(L)	9.14m
Width(W)	1.51m
Height(H)	1.47m
Weight	1.0t

**6m boom insert** ×1

Length(L)	6.14m
Width(W)	1.51m
Height(H)	1.47m
Weight	0.75t

**3m boom insert** ×2

Length(L)	3.14m
Width(W)	1.51m
Height(H)	1.47m
Weight	0.48t

**Fixed jib top** ×1

Length(L)	4.93m
Width(W)	0.87m
Height(H)	0.92m
Weight	0.31t

**Fixed jib base and strut** ×1

Length(L)	4.75m
Width(W)	0.87m
Height(H)	1.18m
Weight	0.75t

**Transport Dimension**

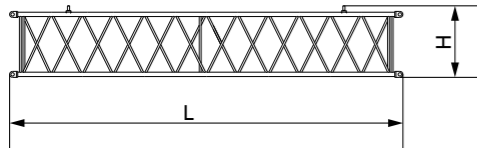

<b>4.5m fixed jib</b>	<b>× 2</b>
Length(L)	4.57m
Width(W)	0.87m
Height(H)	0.83m
Weight	0.24t

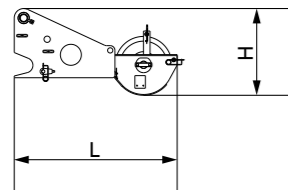

<b>Boom extension jib</b>	<b>× 1</b>
Length(L)	1.55m
Width(W)	0.96m
Height(H)	0.82m
Weight	0.30t

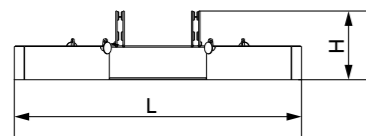

<b>Counterweight tray</b>	<b>× 1</b>
Length(L)	4.40 m
Width(W)	1.37m
Height(H)	1.05m
Weight	8.26t

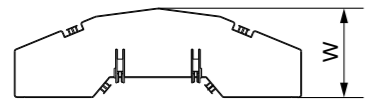

Note: for standardized counterweight, not optional self-assembled one.

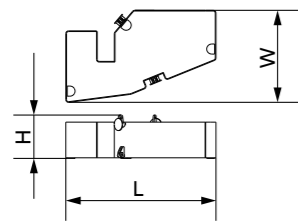

<b>Left counterweight block 1</b>	<b>× 3</b>
Length(L)	2.19 m
Width(W)	1.37m
Height(H)	0.65m
Weight	3.68t

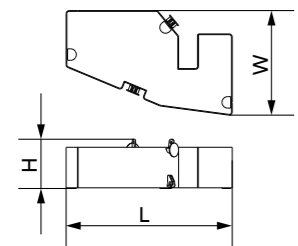

<b>Right counterweight block 1</b>	<b>× 3</b>
Length(L)	2.19 m
Width(W)	1.37m
Height(H)	0.65m
Weight	3.68t

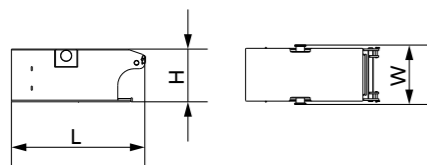

<b>Carbody Counterweight</b>	<b>× 2</b>
Length(L)	2.02 m
Width(W)	0.90m
Height(H)	0.72m
Weight	3t

**Transport Dimension**

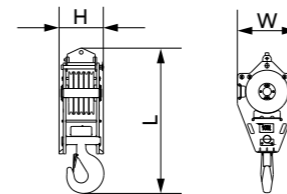

<b>100T hook</b>	<b>× 1</b>
Length(L)	2.08m
Width(W)	0.85m
Height(H)	0.63m
Weight	1.36t

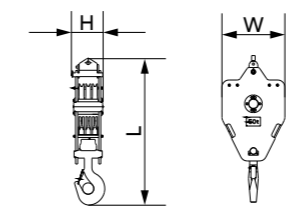

<b>50T hook</b>	<b>× 1</b>
Length(L)	1.95 m
Width(W)	0.90m
Height(H)	0.45m
Weight	1.04t

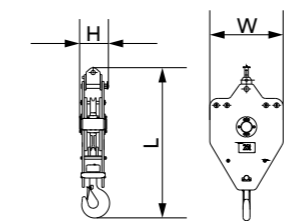

<b>25T hook</b>	<b>× 1</b>
Length(L)	1.86 m
Width(W)	0.90m
Height(H)	0.35m
Weight	0.79t

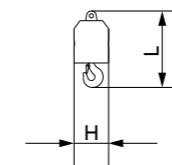

<b>13.5T ball hook</b>	<b>× 1</b>
Length(L)	0.95m
Width(W)	0.43m
Height(H)	0.43m
Weight	0.47t

Note:

1.The transport dimensions of each part in the table are schematic, not proportional to the real parts. The dimensions are designed value without package considered.

2.The Weight is designed value that the actual manufactured part may deviate a little.



## Transport Plan

### Transport with crawler frames

Trailer 1	
Part(s)	▪ Basic Machine
Weight	▪ 46.5t

Note: The crawler frames can be removed for transport, which meets the 3m transport width.

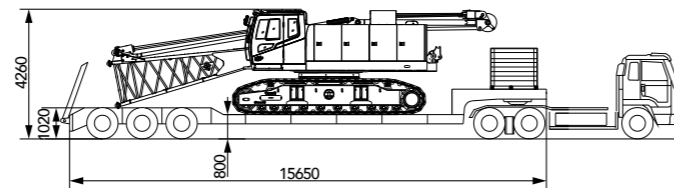

Trailer 2	
Part(s)	<ul style="list-style-type: none"> <li>▪ 9m boom x2</li> <li>▪ 6m boom x1</li> <li>▪ 3m boom x1</li> <li>▪ Extension jib x1</li> <li>▪ 4.5m fixed jib x2</li> <li>▪ Left counterweight x2</li> <li>▪ Right counterweight x1</li> <li>▪ 100t hook x1</li> <li>▪ 50t hook x1</li> <li>▪ 25t hook x1</li> <li>▪ 13.5t hook x1</li> </ul>
Weight	▪ 22.4t

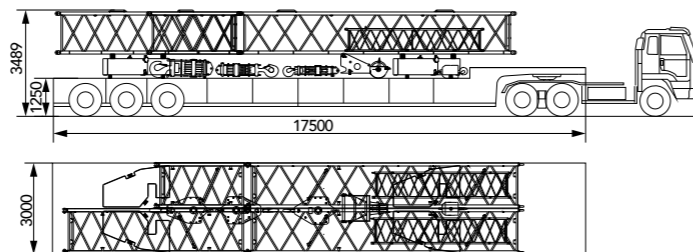

Trailer 3	
Part(s)	<ul style="list-style-type: none"> <li>▪ 9m boom x2</li> <li>▪ 3m boom x1</li> <li>▪ Boom top x1</li> <li>▪ Fixed jib base x1</li> <li>▪ Fixed jib top x1</li> <li>▪ Counterweight tray x1</li> <li>▪ Left counterweight x1</li> <li>▪ Right counterweight x1</li> <li>▪ Carbody counterweight x2</li> </ul>
Weight	▪ 26.5t

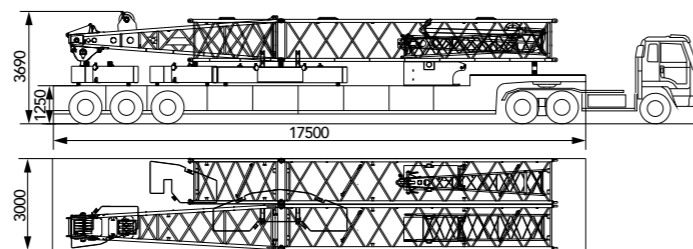

## SCC900A SANY CRAWLER CRANE 90 TONS LIFTING CAPACITY

QUALITY CHANGES THE WORLD

### Configuration

- Page 19 H Configuration
- Page 23 FJ Configuration



**Boom Combination**

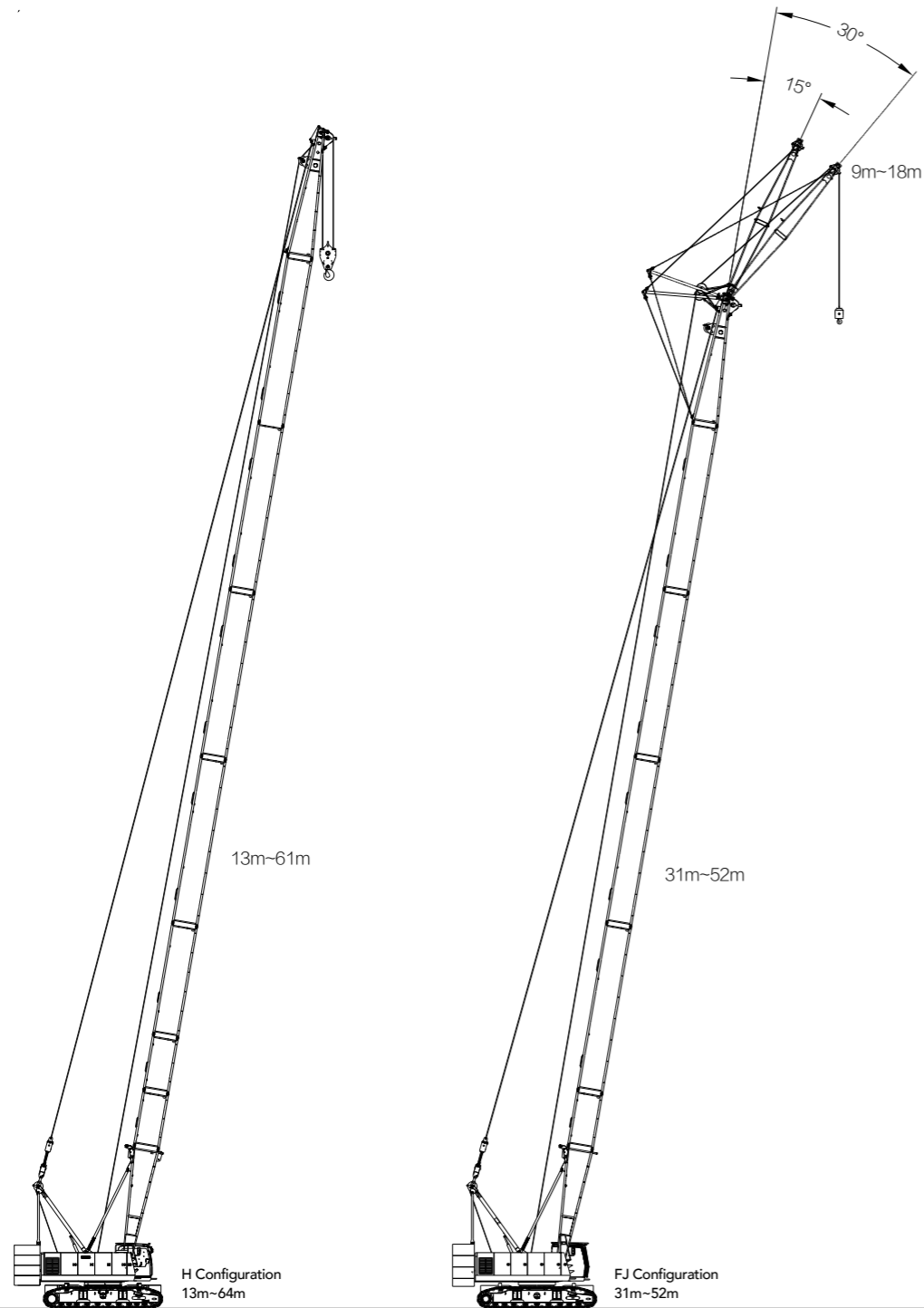

**Boom Combination in H**

**Boom Combination in H Configuration**

Boom length (m)	Insert		
	3m	6m	9m
13	-	-	-
16	1	-	-
19	-	1	-
22	-	-	1
25	1	-	1
28	-	1	1
31	1	1	1
34	-	-	2
37	1	1	2
40	-	-	3
43	1	-	3
46	-	1	3
49	1	1	3
52	-	-	4
55	1	-	4
58	-	1	4
61	1	1	4

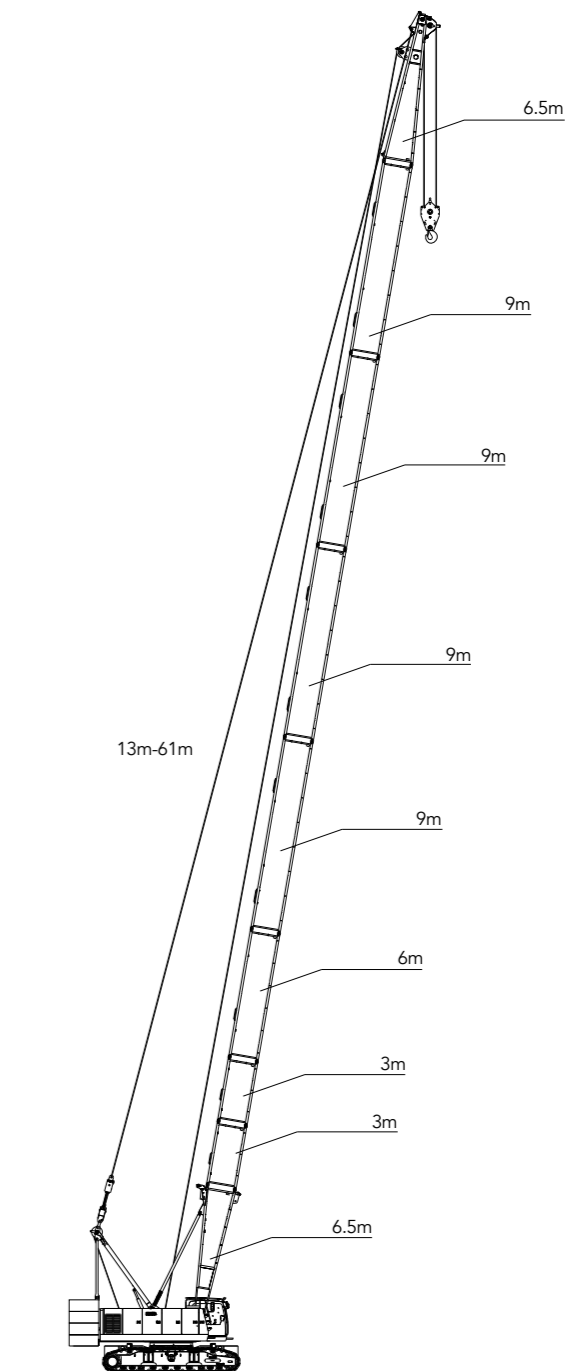

### Working Radius in H Configuration

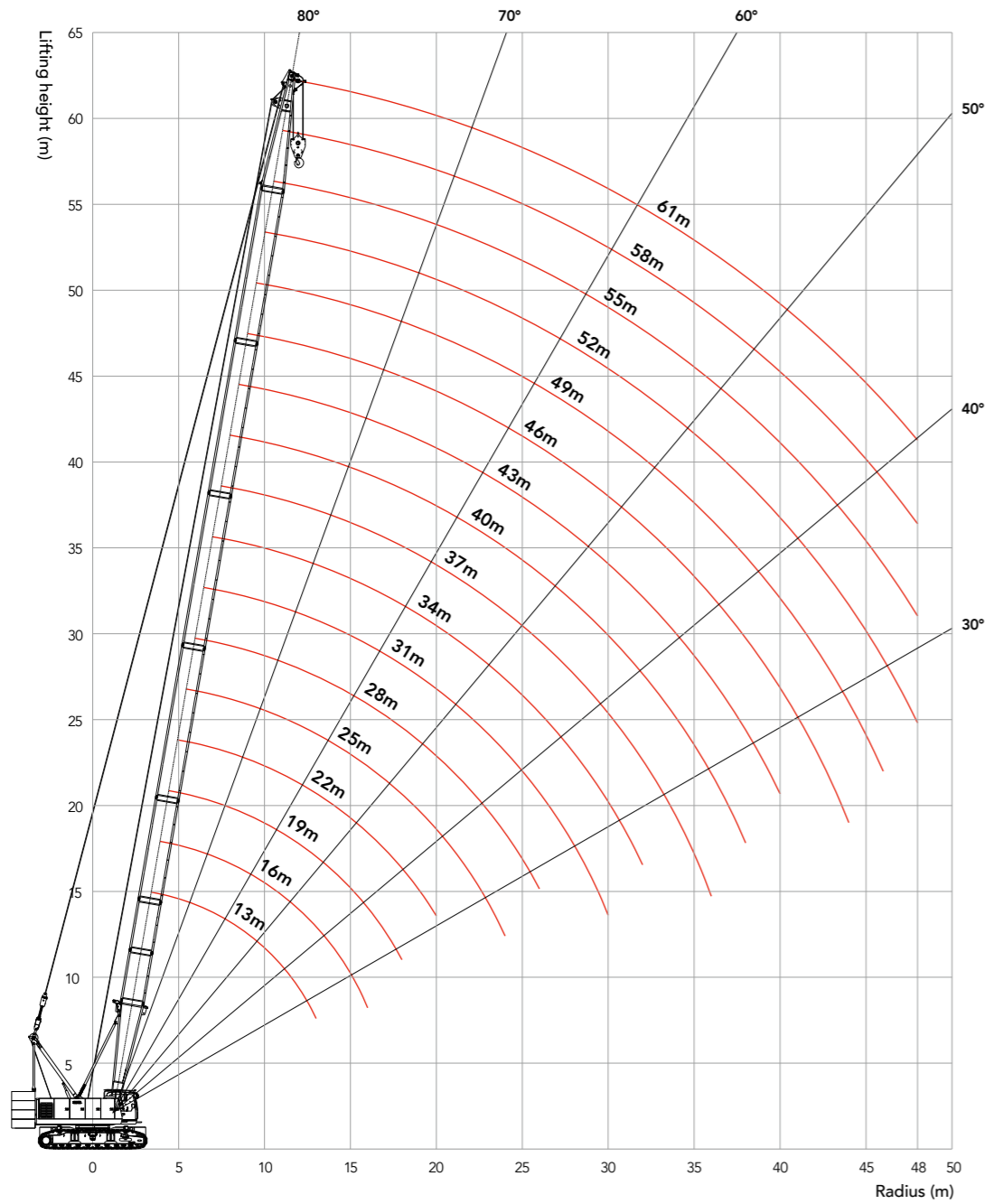

### Load Chart of H Configuration

Unit: t

SCC900A - H 1/2										
30.3t Rear Counterweight + 6t Carbody Counterweight										
R/BL (m)	13	16	19	22	25	28	31	34	37	R/BL (m)
4	90									4
4.5	80									4.5
5	72	72								5
5.5	65	65	65							5.5
6	59.5	58.9	58.4	57.8						6
6.5	52.6	52.1	51.7	51.3	50.7					6.5
7	47.2	46.7	46.4	46	45.6	45.1				7
7.5	42.7	42.3	42	41.7	41.3	41	40.5			7.5
8	39	38.6	38.3	38	37.7	37.4	37.1	36.6		8
9	33.2	32.8	32.6	32.4	32.1	31.8	31.6	31.3	31	9
10	28.8	28.5	28.3	28.1	27.8	27.6	27.4	27.1	26.9	10
11	25.4	25.1	24.9	24.8	24.5	24.3	24.1	23.8	23.6	11
12	22.7	22.4	22.3	22.1	21.8	21.6	21.5	21.2	21	12
13	20.5	20.2	20.1	19.9	19.7	19.5	19.3	19.1	18.9	13
14		18.4	18.2	18.1	17.8	17.7	17.5	17.3	17.1	14
15		16.8	16.7	16.5	16.3	16.1	16	15.8	15.6	15
16		15.5	15.3	15.2	15	14.8	14.7	14.4	14.3	16
18			13.2	13.1	12.8	12.7	12.5	12.3	12.2	18
20				11.4	11.1	11	10.9	10.6	10.5	20
22					9.8	9.7	9.5	9.3	9.2	22
24					8.7	8.6	8.4	8.2	8.1	24
26						7.6	7.5	7.3	7.2	26
28							6.7	6.5	6.4	28
30							6.1	5.8	5.7	30
32								5.3	5.1	32
34									4.6	34
36									4.2	36

**Load Chart of H Configuration**

SCC900A – H 2/2									
30.3t Rear Counterweight + 6t Carbody Counterweight									
R/BL (m)	40	43	46	49	52	55	58	61	R/BL (m)
10	26.7	26.4							10
11	23.5	23.2	23	22.7					11
12	20.9	20.6	20.4	20.3	20				12
13	18.7	18.5	18.3	18.2	17.9	17.7			13
14	17	16.7	16.5	16.4	16.2	16	15.7	14	14
15	15.4	15.2	15	14.9	14.7	14.5	14.3	13.5	15
16	14.1	13.9	13.7	13.6	13.4	13.2	13	12.7	16
18	12	11.8	11.6	11.5	11.3	11.1	10.9	10.7	18
20	10.4	10.1	10	9.8	9.6	9.5	9.3	9.1	20
22	9	8.8	8.7	8.5	8.3	8.2	8	7.8	22
24	7.9	7.7	7.6	7.4	7.2	7.1	6.9	6.7	24
26	7	6.8	6.7	6.5	6.3	6.2	6	5.8	26
28	6.3	6	5.9	5.8	5.5	5.4	5.2	5	28
30	5.6	5.4	5.2	5.1	4.9	4.7	4.6	4.3	30
32	5	4.8	4.6	4.5	4.3	4.2	4	3.8	32
34	4.5	4.3	4.1	4	3.8	3.7	3.5	3.3	34
36	4.1	3.8	3.7	3.6	3.3	3.2	3	2.8	36
38	3.7	3.4	3.3	3.2	2.9	2.8	2.6	2.4	38
40		3.1	2.9	2.8	2.6	2.5	2.3	2.1	40
42			2.6	2.5	2.3	2.1	2	1.7	42
44			2.3	2.2	2	1.8	1.7	1.5	44
46				1.9	1.7	1.6	1.4	1.2	46
48					1.5	1.3	1.2	0.9	48

Notes: Rated capacity of crawler crane

- ① The rated capacity in the load charts is calculated based when the crane is parking on firm and level ground, lifting the load slowly and steadily.
- ② The shaded values are determined by strength.
- ③ The rated capacity values listed in the load charts are only valid when wind speed is lower than 9.8m/s.
- ④ The rated capacity listed in the load charts includes the weight of hook, wire rope and other riggings; therefore, the actual rated capacity shall deduct the weight of these components. (1.36t of 100t hook weight, 1.04t of 50t hook weight, 0.79t of 25t hook weight, 0.45t of 13.5t hook weight).
- ⑤ The crawlers must be extended during lifting.
- ⑥ The values listed in the load charts are valid for 360° swing.

**Boom Combination of FJ Configuration**

**Boom Combination of FJ Configuration**

Jib Length (m)	Insert
	4.5m
9	-
13.5	1
18	2

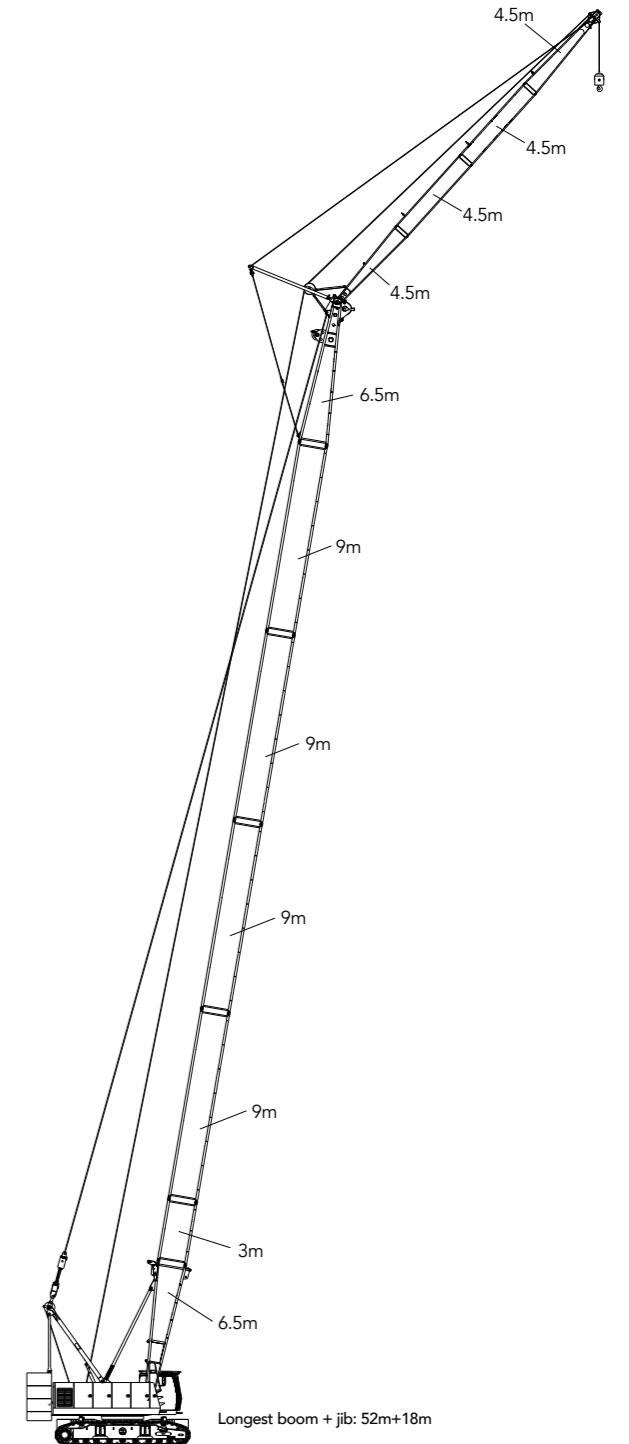

**Working Radius in FJ Configuration**

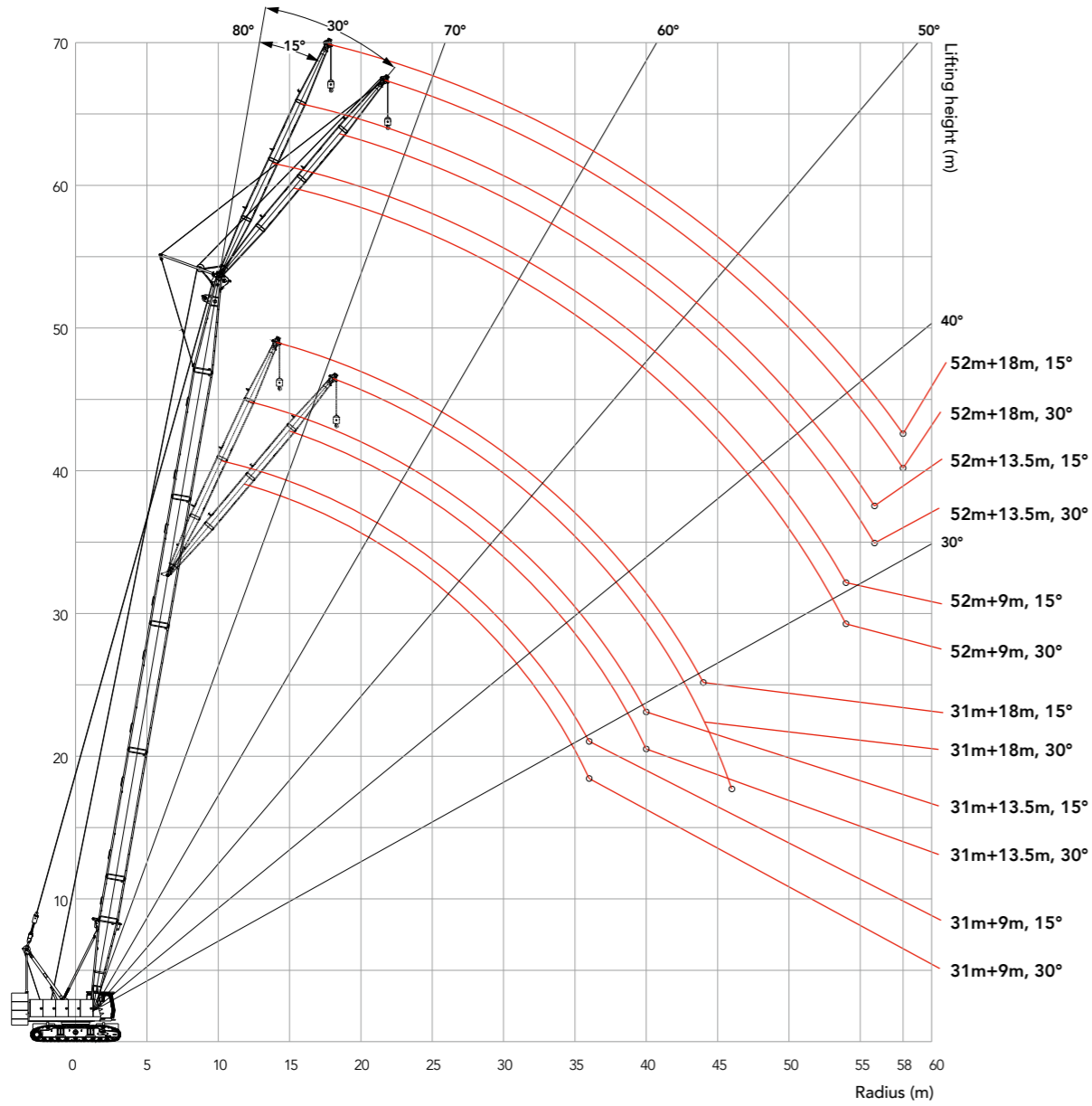

**Load Chart of FJ Configuration**

Unit: t

SCC900A – FJ 1/4														
30.3t Rear Counterweight + 6t Carbody Counterweight														
R/BL (m) Jib Length (m) Boom to Jib Angle	31						34						R/BL (m) Jib Length (m) Boom to Jib Angle	
	9		13.5		18		9		13.5		18			
	15°	30°	15°	30°	15°	30°	15°	30°	15°	30°	15°	30°		
12	11													12
13	11							11						13
14	11	11	11					11	11					14
15	11	11	11					11	11	11				15
16	11	11	11	10.3	11			11	11	11		11		16
18	11	11	11	9.7	10.5			11	11	11	9.7	10.5		18
20	11	11	11	9	9.7	7.2		10.9	11	11	9	9.7	7.2	20
22	9.7	9.9	9.8	8.7	9	6.8		9.5	9.7	9.7	8.7	9	6.8	22
24	8.6	8.8	8.7	8.3	8.4	6.4		8.4	8.6	8.5	8.3	8.4	6.4	24
26	7.7	7.8	7.8	7.9	7.8	6.1		7.5	7.7	7.6	7.8	7.7	6.1	26
28	6.9	7	7	7.2	7	5.9		6.7	6.8	6.8	7	6.9	5.9	28
30	6.2	6.3	6.3	6.5	6.3	5.6		6	6.1	6.1	6.3	6.2	5.6	30
32	5.6	5.7	5.7	5.9	5.7	5.4		5.4	5.5	5.5	5.7	5.6	5.4	32
34	5.1	5.2	5.2	5.3	5.2	5.2		4.9	5	5	5.2	5	5.2	34
36	4.7	4.7	4.7	4.8	4.8	4.9		4.5	4.5	4.5	4.7	4.6	4.8	36
38			4.3	4.4	4.3	4.5		4.1	4.1	4.1	4.2	4.2	4.3	38
40			3.9	4	4	4.1				3.8	3.8	3.8	3.9	40
42					3.6	3.7				3.4	3.5	3.5	3.6	42
44					3.3	3.4					3.2	3.1	3.2	44
46						3.1						2.9	2.9	46
48												2.6	2.7	48

**Load Chart of FJ Configuration**

SCC900A – FJ 2/4													
30.3t Rear Counterweight + 6t Carbody Counterweight													
R/BL (m) Jib Length (m) Boom to Jib Angle	37						40						R/BL (m) Jib Length (m) Boom to Jib Angle
	9		13.5		18		9		13.5		18		
	15°	30°	15°	30°	15°	30°	15°	30°	15°	30°	15°	30°	
13	11												13
14	11						11						14
15	11	11	11				11						15
16	11	11	11				11	11	11				16
18	11	11	11	9.7	10.5		11	11	11		10.5		18
20	10.8	11	10.9	9	9.7		10.6	10.9	10.8	9	9.7		20
22	9.4	9.6	9.5	8.7	9	6.8	9.3	9.5	9.4	8.7	9	6.8	22
24	8.3	8.5	8.4	8.3	8.4	6.4	8.2	8.4	8.3	8.3	8.4	6.4	24
26	7.4	7.5	7.5	7.7	7.5	6.1	7.2	7.4	7.4	7.6	7.4	6.1	26
28	6.6	6.7	6.7	6.9	6.7	5.9	6.5	6.6	6.6	6.8	6.6	5.9	28
30	5.9	6	6	6.2	6	5.6	5.8	5.9	5.9	6.1	5.9	5.6	30
32	5.3	5.4	5.4	5.6	5.4	5.4	5.2	5.3	5.3	5.5	5.3	5.4	32
34	4.8	4.9	4.9	5	4.9	5.1	4.7	4.8	4.8	4.9	4.8	5	34
36	4.3	4.4	4.4	4.6	4.5	4.7	4.2	4.3	4.3	4.5	4.3	4.6	36
38	3.9	4	4	4.1	4	4.2	3.8	3.9	3.9	4	3.9	4.1	38
40	3.6	3.6	3.6	3.7	3.7	3.8	3.4	3.5	3.5	3.6	3.5	3.7	40
42	3.2	3.3	3.3	3.4	3.3	3.5	3.1	3.1	3.2	3.3	3.2	3.4	42
44			3	3.1	3	3.1	2.8	2.8	2.9	3	2.9	3	44
46			2.7	2.8	2.7	2.8			2.6	2.7	2.6	2.7	46
48					2.5	2.6			2.3	2.4	2.4	2.5	48
50					2.3	2.3					2.1	2.2	50
52											1.9	2	52
54												1.7	54

**Load Chart of FJ Configuration**

SCC900A – FJ 3/4													
30.3t Rear Counterweight + 6t Carbody Counterweight													
R/BL (m) Jib Length (m) Boom to Jib Angle	43						46						R/BL (m) Jib Length (m) Boom to Jib Angle
	9		13.5		18		9		13.5		18		
	15°	30°	15°	30°	15°	30°	15°	30°	15°	30°	15°	30°	
14	11												14
15	11						11						15
16	11	11	11				11						16
18	11	11	11				11	11	11				18
20	10.4	10.7	10.6	9	9.7		10.3	10.6	10.5	9	9.6		20
22	9.1	9.4	9.2	8.7	9	6.8	9	9.2	9.1	8.7	8.9		22
24	8	8.2	8.1	8.3	8.2	6.4	7.9	8.1	8	8.3	8.1	6.4	24
26	7.1	7.3	7.2	7.5	7.3	6.1	6.9	7.1	7.1	7.4	7.1	6.1	26
28	6.3	6.4	6.4	6.7	6.4	5.9	6.1	6.3	6.3	6.6	6.3	5.9	28
30	5.6	5.7	5.7	5.9	5.8	5.6	5.5	5.6	5.6	5.8	5.6	5.6	30
32	5	5.1	5.1	5.3	5.2	5.4	4.9	5	5	5.2	5	5.4	32
34	4.5	4.6	4.6	4.8	4.6	4.9	4.4	4.5	4.5	4.7	4.5	4.8	34
36	4	4.1	4.1	4.3	4.2	4.4	3.9	4	4	4.2	4	4.3	36
38	3.6	3.7	3.7	3.9	3.7	4	3.5	3.6	3.6	3.8	3.6	3.9	38
40	3.2	3.3	3.3	3.5	3.4	3.6	3.1	3.2	3.2	3.4	3.3	3.5	40
42	2.9	3	3	3.1	3	3.2	2.8	2.9	2.9	3	2.9	3.1	42
44	2.6	2.7	2.7	2.8	2.7	2.9	2.5	2.6	2.6	2.7	2.6	2.8	44
46	2.3	2.4	2.4	2.5	2.5	2.6	2.2	2.3	2.3	2.4	2.3	2.5	46
48			2.2	2.2	2.2	2.3	2	2	2	2.1	2.1	2.2	48
50			1.9	2	2	2.1		1.8	1.8	1.9	1.8	2	50
52				1.7	1.7	1.8			1.6	1.6	1.6	1.7	52
54					1.5	1.6			1.4	1.4	1.4	1.5	54
56					1.3	1.4					1.2	1.3	56
58											1	1.1	58

**Load Chart of FJ Configuration**

**Notes**

SCC900A – FJ 4/4														
30.3t Rear Counterweight + 6t Carbody Counterweight														
R/BL (m) Jib Length (m) Boom to Jib Angle	49						52						R/BL (m) Jib Length (m) Boom to Jib Angle	
	9		13.5		18		9		13.5		18			
	15°	30°	15°	30°	15°	30°	15°	30°	15°	30°	15°	30°		
15	11													15
16	11						11							16
18	11	11	11				11	11	11					18
20	10.2	10.5	10.3	9	9		10	10.4	10.2		8.3			20
22	8.8	9.1	9	8.7	8.7		8.6	9	8.8	8.7	8.1			22
24	7.7	8	7.9	8.3	8	6.4	7.5	7.8	7.7	8.1	7.8	6.4		24
26	6.8	7	6.9	7.3	7	6.1	6.6	6.9	6.8	7.1	6.9	6.1		26
28	6	6.2	6.1	6.5	6.2	5.9	5.8	6	6	6.3	6.1	5.9		28
30	5.3	5.5	5.4	5.7	5.5	5.6	5.1	5.3	5.3	5.6	5.4	5.6		30
32	4.7	4.9	4.9	5.1	4.9	5.3	4.6	4.7	4.7	5	4.8	5.1		32
34	4.2	4.4	4.3	4.6	4.4	4.7	4	4.2	4.2	4.4	4.2	4.6		34
36	3.8	3.9	3.9	4.1	3.9	4.2	3.6	3.7	3.7	3.9	3.8	4.1		36
38	3.4	3.5	3.5	3.6	3.5	3.8	3.2	3.3	3.3	3.5	3.3	3.6		38
40	3	3.1	3.1	3.3	3.1	3.4	2.8	2.9	2.9	3.1	3	3.2		40
42	2.7	2.8	2.8	2.9	2.8	3	2.5	2.6	2.6	2.7	2.6	2.9		42
44	2.4	2.4	2.4	2.6	2.5	2.7	2.2	2.3	2.3	2.4	2.3	2.5		44
46	2.1	2.2	2.2	2.3	2.2	2.4	1.9	2	2	2.1	2	2.2		46
48	1.8	1.9	1.9	2	2	2.1	1.7	1.7	1.7	1.9	1.8	2		48
50	1.6	1.7	1.7	1.8	1.7	1.9	1.4	1.5	1.5	1.6	1.5	1.7		50
52	1.4	1.4	1.5	1.5	1.5	1.6	1.2	1.2	1.3	1.4	1.3	1.5		52
54			1.3	1.3	1.3	1.4	1	1	1.1	1.2	1.1	1.2		54
56			1.1	1.1	1.1	1.2			0.9	1	0.9	1		56
58					0.9	1					0.8	0.8		58

Notes: Rated capacity of crawler crane

- ① The rated capacity in the load charts is calculated based when the crane is parking on firm and level ground, lifting the load slowly and steadily.
- ② The shaded values are determined by strength.
- ③ The rated capacity values listed in the load charts are only valid when wind speed is lower than 9.8m/s.
- ④ The rated capacity listed in the load charts includes the weight of hook, wire rope and other riggings; therefore, the actual rated capacity shall deduct the weight of these components. (1.36t of 100t hook weight, 1.04t of 50t hook weight, 0.79t of 25t hook weight, 0.45t of 13.5t hook weight).
- ⑤ The crawlers must be extended during lifting.
- ⑥ The values listed in the load charts are valid for 360° swing.

Notes

---





## Zhejiang SANY Equipment Co., Ltd.

SANY Industrial Park, No. 2087 Daishan Road, Wuxing District, Huzhou City,  
Zhejiang Province, P. R. of China Zip 313028  
After-sales Service 400 887 8318  
Consulting 400 887 9318

— Agent information —

Due to updated technology, the technical parameters and configurations are subject to change without prior notice. The machine in the picture may include additional equipment. This album is for reference only, subject to the object.  
All rights reserved for Sany, without the written permission of Sany, the contents of any part of this content shall not be copied or copied for any purpose.

© Printed in January 2018 in China

[www.sany.com.cn](http://www.sany.com.cn)



Please scan the official WeChat account of Sany for more information.