

CROWN

SC 5300 SERIES

Specifications

Three Wheel Counterbalance Truck



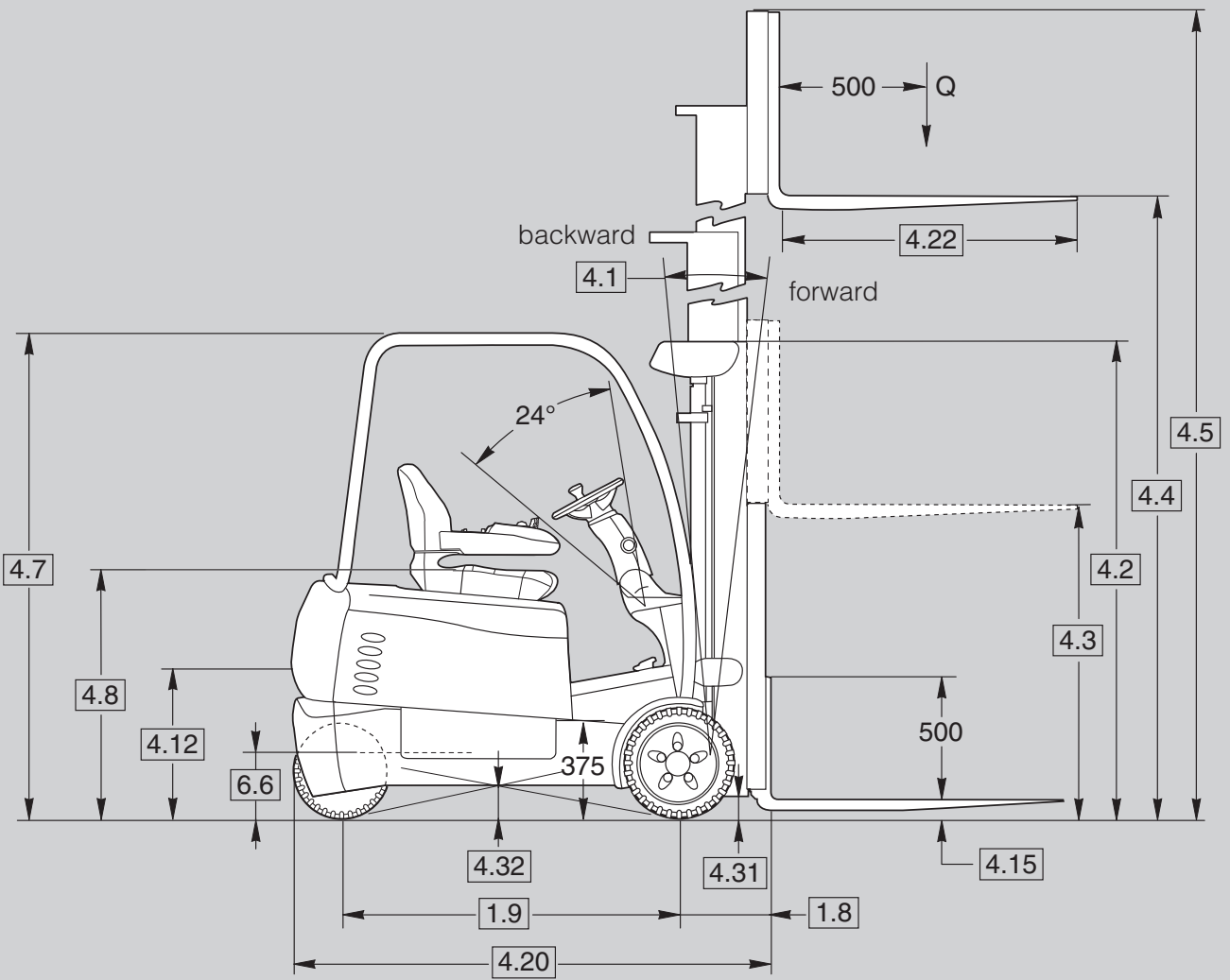
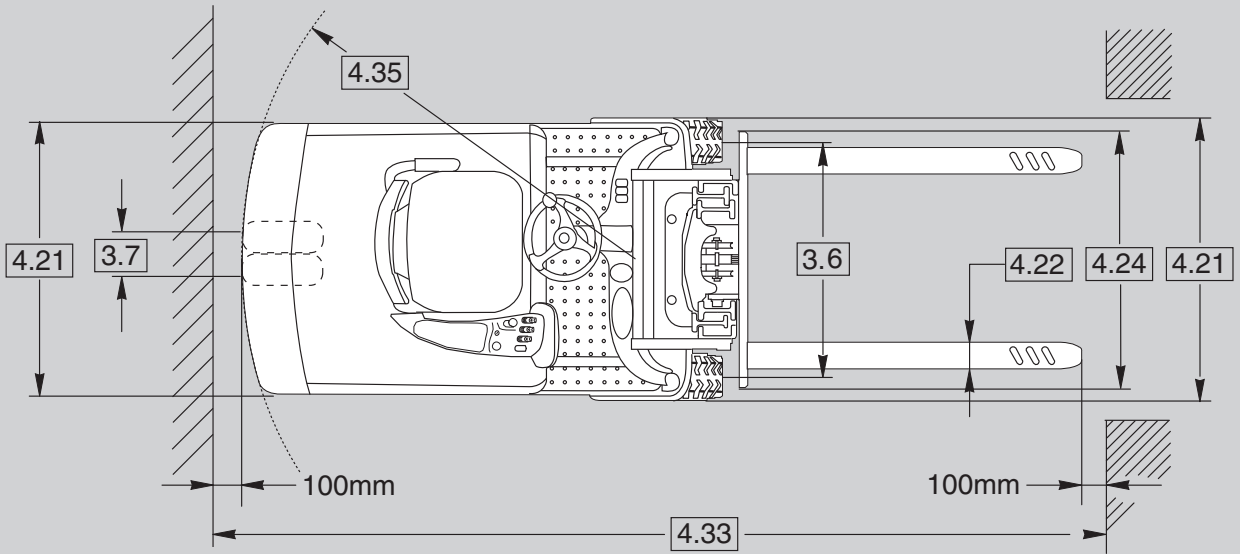

SC 5300 Series

Specifications

General Information	1.1	Manufacturer	Crown Equipment Corporation									
	1.2	Model				SC 5310	SC 5320	SC 5320	SC 5340	SC 5340	SC 5360	SC 5360
						1.3	1.3	1.6	1.6	1.8	1.8	2.0
	1.3	Power	electric			battery						
	1.4	Operator Type				sit down						
	1.5	Load Capacity		Q	t	1.25	1.25	1.6	1.6	1.8	1.8	2.0
	1.6	Load Centre		c	mm	500						
	1.8	Load Distance		x	mm	362	362	362	362	368	368	368
	1.9	Wheel Base		y	mm	1173	1281	1281	1389	1389	1497	1497
Weights	2.1	Weight	less battery		kg	2700	2730	2730	2740	2750	2880	2880
	2.2	Axle Load	w. load front / rear		kg	3850/630	3870/790	4450/550	4420/730	4770/590	4820/820	5140/700
	2.3	Axle Load	w.o. load front / rear		kg	1690/1550	1780/1630	1770/1630	1830/1720	1840/1720	1980/1860	1980/1860
Tyres	3.1	Tyre Type				Super Elastic / SE						
	3.2	Tyres	front		inch	18x7-8	18x7-8	18x7-8	18x7-8	200/50-10	200/50-10	200/50-10
	3.3		rear		mm	15 x 4.5 - 8						
	3.5	Wheels	no. (x=driven) front/rear			2x / 2						
	3.6	Track Width	load side	b10	mm	889	889	889	889	914	914	914
	3.7		power unit side	b11	mm	176						
	Dimensions	4.1	Mast Tilt	forward / backward		°	see table 1					
4.2		Mast	collapsed height	h1	mm	see table 1						
4.3		Free Lift	w. / w.o. lbr	h2	mm	see table 1						
4.4		Lift Height		h3	mm	see table 1						
4.5		Mast	extended height	h4	mm	see table 1						
4.7		Overhead Guard Height	standard/optional low	h6	mm	2080 / 1991						
4.8		Seat Height		h7	mm	1075						
4.12		Tow Hitch Height		h10	mm	580						
4.15		Lowered Fork Height		h13	mm	45						
4.20		Headlength *		l2	mm	1732	1840	1840	1948	1954	2062	2062
4.21		Overall Width		b1/b2	mm	1071	1071	1071	1071	1123	1123	1123
4.22		Fork Dimension		thxw	mm	38x100	38x100	38x100	38x100	45x100	45x100	45x100
			standard / option	l	mm	990 / 760, 915, 1065, 1145, 1220, 1370, 1525						
4.23		Fork Carriage	ISO / FEM	b5	mm	2 A						
4.24		Fork Carriage Width	w. lbr / w.o. lbr	b3	mm	990 / 965						
4.31	Ground Clearance	with load below mast	m1	mm	76							
4.32		centre wheel base	m2	mm	115							
4.33	Working Aisle Width	minimum		mm	see table 2							
4.35	Turning Radius		Wa	mm	1370	1478	1478	1586	1586	1694	1694	
Performance	5.1	Travel Speed	w./w.o. load		km/h	16 / 16 **						
	5.2	Lift Speed	w./w.o. load		m/s	0.56/0.39	0.56/0.39	0.56/0.38	0.56/0.38	0.56/0.37	0.56/0.37	0.56/0.36
	5.3	Lower Speed	w./w.o. load		m/s	0.50/0.50						
	5.5	Tractive Effort	w./w.o. load (60 min. rtg.)		N	5180/5430	5150/5390	5080/5390	5040/5360	5000/5350	4950/5310	4910/5310
	5.6	Max. Tractive Effort	with load		N	11560	11520	11450	11410	11370	11320	11280
			without load		N	11800	11760	11760	11730	11720	11680	11680
	5.7	Gradeability	w./w.o. load (60 min. rtg.)		%	11.6/16.7	11.0/15.7	10.1/15.7	9.7 / 14.8	9.3 / 14.7	8.8 / 13.7	8.4 / 13.7
	5.8	Max. Gradeability	w./w.o. load (intermit)		%	26 / 36	25 / 34	23 / 34	22 / 32	21 / 32	20 / 30	19 / 30
	5.9	Acceleration Time	w./w.o. load		s	4.4 / 3.8	4.5 / 3.9	4.5 / 3.9	4.5 / 3.9	4.6 / 4.0	4.7 / 4.1	4.7 / 4.1
	5.10	Brake	service			Regenerative electric brake						
parking					Dual disc automatic park brake							
Motors	6.1	Traction Motor	60 min. rating		kW	2 x 4.8						
	6.2	Lift Motor	15% on time		kW	7.9						
	6.3	Max. Battery Box Size	DIN 43531	l	mm	414	522	522	630	630	738	738
			Layout A	wxh	mm	830 x 627						
	6.4	Battery Voltage	Voltage		V	48						
			min./max.		Ah	330-375	440-500	440-500	550-625	550-625	660-750	660-750
6.5	Battery Weight	min./max.		kg	532/588	673/743	673/743	813/899	813/899	962/1064	962/1064	
6.6	Battery Floor Height	with / without rollers		mm	265 / 250							
Misc.	8.1	Type of Control	drive / lift			Transistor						
	8.2	Available Working Pressure for Attachments		bar	235							

* +59 mm for hook on sideshift

** travel speed reduction applicable to trucks with lift height above 2260 mm collapsed height

Table 1 – Mast Chart

				TL Mast							
				SC 5310 SC 5320 SC 5340 SC 5360						SC 5320 SC 5340 SC 5360	
4.1	Mast Tilt	forward / backward	°	5/5	5/5	5/5	5/3	5/3	5/3	5/3	5/3
4.2	Mast	collapsed height	h1 mm	1955	2110	2260	2415	2540	2665	2845*	3035**
4.3	Free Lift		h2 mm	155	155	155	155	155	155	155	155
4.4	Lift Height		h3 mm	2890	3190	3500	3805	4055	4200	4555	4935
4.5	Mast	extended height, w.o. lbr.	h4 mm	3470	3775	4080	4385	4640	4780	5135	5520
		ext. height, w. lbr. 1220 mm	h4 mm	4110	4415	4720	5025	5275	5420	5775	6155

				TF Mast		Quad
				SC 5310 SC 5320 SC 5340 SC 5360		SC 5310 SC 5320 SC 5340 SC 5360
4.1	Mast Tilt	forward / backward	°	5/5	5/5	2/3
4.2	Mast	collapsed height	h1 mm	1955	2110	2110
4.3	Free Lift	without load backrest	h2 mm	1345	1500	1560
		with load backrest	h2 mm	730	885	845
4.4	Lift Height		h3 mm	2890	3195	6095
4.5	Mast	extended height, w.o. lbr.	h4 mm	3495	3800	6620
		ext. height, w. lbr. 1220 mm	h4 mm	4110	4415	7335

				TT Mast							
				SC 5310 SC 5320 SC 5340 SC 5360						SC 5320 SC 5340 SC 5360	
4.1	Mast Tilt	forward / backward	°	5/5	5/5	5/5	5/3	5/3	5/3	5/3	5/3
4.2	Mast	collapsed height	h1 mm	1955	2110	2260	2415	2540	2665	2845*	3035**
4.3	Free Lift	without load backrest	h2 mm	1450	1605	1755	1970	2035	2165	2340	2530
		with load backrest	h2 mm	735	890	1040	1195	1320	1450	1625	1815
4.4	Lift Height		h3 mm	4370	4825	5285	5740	6120	6390	6925	7495
4.5	Mast	extended height, w.o. lbr.	h4 mm	4875	5330	5790	6245	6625	6895	7430	8000
		ext. height, w. lbr. 1220 mm	h4 mm	5590	6045	6505	6960	7340	7610	8145	8715

* not available on SC 5310

** not available on SC 5310, SC 5320, SC 5360

Table 2 – Working Aisle Width

	1.9	1.8	4.35	Pallets length x width	4.33		
	Wheelbase	Load Distance	Turning Radius		Aisle Width according to VDI 2198		
	Y	X	Wa		w.o. sideshift	integrated sideshift	with hook-on sideshift
SC 5310 1.3	1173	362	1370	800 x 1200	2877	2903	2927
				1200 x 800	3182	3210	3236
				1000 x 1200	3058	3084	3109
				1200 x 1000	3209	3237	3263
SC 5320 1.3 SC 5320 1.6	1281	362	1478	800 x 1200	2985	3011	3035
				1200 x 800	3290	3318	3344
				1000 x 1200	3166	3192	3217
				1200 x 1000	3317	3345	3371
SC 5340 1.6	1389	362	1586	800 x 1200	3093	3119	3143
				1200 x 800	3398	3426	3452
				1000 x 1200	3274	3300	3325
				1200 x 1000	3425	3453	3479
SC 5340 1.8	1389	368	1586	800 x 1200	3098	3124	3148
				1200 x 800	3403	3431	3457
				1000 x 1200	3279	3305	3330
				1200 x 1000	3430	3458	3484
SC 5360 1.8 SC 5360 2.0	1497	368	1694	800 x 1200	3206	3232	3256
				1200 x 800	3511	3540	3566
				1000 x 1200	3387	3414	3438
				1200 x 1000	3539	3567	3592

Standard Equipment

1. Crown's Access 1 2 3® Comprehensive System Control
2. InfoPoint™ System
3. Crown-manufactured AC drive and AC lift motors
4. e-GEN™ Braking System with automatic parking brake
5. Adjustable armrest, forward / backwards with
 - Fingertip control levers
 - Thumb operated travel direction switch
6. Intrinsic Stability System
 - Travel speed reduction and appropriate electronic brake control when forks are above free lift
 - Forward tilt interlock reduces forward tilt above freelif to maximise stability
 - Controlled tilt speeds
 - Counterweight exceeds required standards
 - Cornering speed control
 - Ramp hold
 - Ramp speed control
7. Driveability standard features
 - 375 mm step height
 - Large, unobstructed floorboard
 - Non-slip rubber floor mat
 - Automotive type rubber covered accelerator and brake pedals
 - Automatic parking brake (seat activated)
 - Large, entry/exit "window"
 - Entry/exit to both sides
 - Rounded edges on battery cover for easy entry/exit
 - Comfort suspension safety seat MSG 65 vinyl with hip restraint
 - High visibility orange anti-cinch safety belt
 - Storage tray on seatdeck
 - Compact steering column and steering wheel with spinner knob
 - Infinitely adjustable tilt steering column
 - Operator-forward design for enhanced visibility
 - Low dashboard for fork and floor visibility

8. Crown display
 - Battery discharge indicator with lift interrupt and re-key feature
 - Hour meters / travel distance / stop watch
 - Pin code access capable
 - Event code display with five (5) key navigation
 - Access 1 2 3 diagnostics
 - P1, P2, P3 Performance tuning
9. SBE 320 blue battery connector
10. DIN 43531 battery compartment sizes
 - Lift out or side extraction battery access
11. Dual 15" Super Elastic steer tyres
12. Large 18" Super Elastic drive tyres
13. On-demand power steering
14. Proportional rack and pinion steering
15. Waterfall design overhead guard 2080 mm high
16. No tool lift out floorboards for service access
17. 48 volt system
18. High visibility mast with in-line hose routing
19. O-ring face seal hydraulic fittings
20. 5° forward / 5° back tilt
21. High visibility triplex mast
22. Tow pin

Optional Equipment

1. TL, TF and Quad mast styles
2. Choice of hydraulic control levers
 - Dual-Axis hydraulic control levers
 - Manual levers, urethane covered control handles with tactile feedback forward reverse switch integrated in
 - Steer column, left or right side
 - 1st hydraulic lever
3. Battery rollers for side extraction
4. Battery transfer system BTS for fast and safe battery exchange

5. Tilt position assist TPA
 - Mast tilt stops in vertical position
6. Auxiliary mast hydraulics
 - single function
 - double function, with 4 spool valve
7. Single or double quick disconnect hydraulic connectors
8. Hook-on or integrated sideshift
9. 1220 mm high load backrest
10. Various fork lengths
11. Choice of tyres
 - Non-marking Super Elastic tyres
 - Standard or non-marking cushion tyres
12. Suspension seat fabric
13. Freezer and corrosion conditioning
14. Low overhead guard, 1991 mm high
15. Light packages
 - Work lights
 - Flashing lights
 - Brake, tail and back-up light
16. InfoLink Ready
17. Audible travel alarm
18. Work Assist™ Accessories
 - Clip pad and hook
 - Clamp
 - Clamp and mounting plate
 - Rear view mirror

Driveability

The SC 5300 Series incorporates numerous design features to improve operator comfort and productivity. A large step positioned at a low height of only 375mm greatly improves entry/exit on both sides of the truck. A low battery cover helps the operator glide into the truck's full suspension seat.

The overhead guard is shaped to open up the entry/exit window on either side. The narrow, offset tilt steer column and steer wheel further facilitate entry/exit. Floorboards are large, unobstructed and rubber covered to insulate the operator from vibration.

Brake and accelerator pedals are rubber covered to provide good grip and comfort. Several designs contribute to better visibility everywhere you look. A low dashboard for fork visibility, a unique waterfall overhead guard for load handling at height, a high visibility mast and a compact steer column all improve operator visibility around the truck. Fingertip controls are integrated into the adjustable armrest. Hydraulic controls allow easy blending of up to 4 hydraulic functions. Dual-Axis controls are recommended when operators wear gloves. The manual levers are urethane covered with tactile feedback for comfort and easy selection. Control actuation forces are minimal and responsive.

Crown Drive System

Crown has applied the latest generation AC drive system, enhanced with Access 1 2 3 technology. The demand for high efficiency systems that closely match customer torque requirements is met with this latest generation control system. Crown-manufactured, independently controlled, AC drive motors are specifically designed to optimise system integration between the traction and braking controls.

Crown's Access 1 2 3 technology provides optimum performance and control by offering a communication interface for operators and technicians, intelligent coordination of lift truck system and simplified service with advanced diagnostics. The Crown display is used for easy troubleshooting, access service history and set performance features. Three modes of performance can be selected to accommodate operator experience or application requirements.

e-GEN™ Braking System

Variable regenerative motor braking is optimised and assisted with electric friction brakes, eliminating maintenance associated with typical wet, disk or drum style brakes. The appropriate amount of stopping force is applied to match operator brake input and the current operating conditions of the truck.

The closed loop Access 1 2 3 traction control will automatically keep the truck on hold until a travel input is requested, even when operating on a ramp.

Automatic electric parking brakes activate when the operator leaves the seat, a travel input has not been requested or battery power has been disconnected.

Proportional Rack and Pinion Steering System

On-demand power steering is served by the main hydraulic pump when steering is requested. The hydrostatic power steering uses a large, totally enclosed rack and pinion gear assembly.

The steering geometry is matched to the controller to deliver smooth steering at all angles. The advantage is less tyre scrubbing which extends tyre life. Both motors receive power, even in the tightest turns. This helps the truck to accelerate, turn and manoeuvre even from a full turn start position.

Cornering speed control regulates the drive motor's output by the turning degree of the truck. The advantage is smooth, stable steering which may increase operator confidence and productivity.

Large, 380 mm diameter dual steer wheels provide good traction and stability and support straight travel over long distances.

Hydraulics

Low noise hydraulic pump serves both lift and steer systems. The hydraulic system provides continuous filtration through suction filter and easy to service return filter.

Hydraulic actuation is precise and oil is controlled using metered spool valves. 3 spool valve for lift/lower, tilt and an auxiliary function is standard and features an integrated pressure relief valve for system protection. A pressure compensation lowering valve ensures safe controlled lowering speeds.

Ram displacement type lift cylinders and two double acting tilt cylinders are Crown-manufactured and designed for long life. All rams and piston rods are hard chrome plated to reduce pitting corrosion and extend cylinder packing life. O-ring face seal fittings are used to eliminate leaks.

Mast Assembly

Crown-manufactured three-stage mast assembly utilises a "flush-face" interlocked I-beam design to improve visibility and reduce truck length. Roller bearing studs are welded on both sides of the rails for maximum strength and roller bearings are canted to run in the thick cross section of the rail. High strength steel mast sections with sealed-for-life rollers are constructed for low mast deflection and high rigidity. Tie bars wrap around the rails for added strength and to resist off-centre load forces.

"In-line" hose routing opens up visibility. Cylinders are placed behind the rails to create a high visibility design.

The mast has four points of attachment to the truck for good load force distribution. Two mounting points are at the frame, where tilt cylinders attach. Tilt cylinders use spherical bushings to resist off-centre load distortions. Two large diameter axles secure the mast to the drive units.

A range of mast types are available:

- TL offers maximum visibility through the mast by eliminating the inner free lift cylinder.
- TF offers widest visibility window with full free lift capability.
- TT offers maximum flexibility with full free lift capability.
- The Quad mast offers maximum lift height at lowest collapsed height.

Drive Units

Two independent drive units are manufactured by Crown. The heavy duty drive unit gears are constantly lubricated in an oil bath. This time proven design is quiet and reliable, providing years of trouble-free service.

Carriage

An FEM / ISO / ITA Class II carriage is standard. Fork spread is adjustable between 314 – 914 mm. An optional hook-on type ISO sideshifter or other attachments are easy to add. Forged high strength steel forks with fork tip indicators are available in various lengths.

Safety Regulations

Conforms to European safety standards. Dimensions and performance data given may vary due to manufacturing tolerances. Performance is based on an average size vehicle and is affected by weight, condition of truck, how it is equipped and the conditions of the operating area. Crown products and specifications are subject to change without notice.

