



RSC223

SOIL COMPACTORS



Integrated design for long life and uptime



Safety starts with an alert, comfortable operator. Air conditioning and filtered air keep the operator cool and on task.



Landfill compactors are essential equipment for maintaining refuse landfill sites. This compactor can push, spread, pulverize, demolish, and compact refuse effectively. Using this type of compactor helps save and protect the environment and extend the operating life of landfill sites.

The constant direction changes, poor underfoot conditions and debris riddled environment of the landfill are easily managed by the rugged and dependable Rhino Soil Compactors drive train components.

Infrared cameras and backup buzzer provide extra safety for the operator and its environment.

Different types of baldes are available to our customers for dozing or spreading to match site requirements.

POWER TRAIN

Engine Make / Model	Rhino D6114
Net Power kW (Hp) @ 2,200 rpm	147(197)
Displacement L (cu. In)	6.1(372)
Emissions Rating (optional)	Tier 2 (Tier 3, Tier 4)
Fuel System	Direct Injection
Lubrication	Full-flow spin-on filter
Aspiration	Turbocharged
Air Cleaner	Under-hood, dual element dry type
Fan Drive	Belt driven
Electrical System	24 Volts with 70 Amp alternator

TRANSMISSION

Type	Hydrostatic all-wheel-drive travel with powershift allows torque to be distributed to the right places and change direction when needed
Min. Travel Speed kmh (mph)	4.2(2.6)
Max. Travel Speed kmh (mph)	10.0(6.2)

HYDRAULIC SYSTEM

Pump Type	Load sensing axial piston pump, Variable displacement, Closed Center
System Pressure Mpa (psi)	12(1,740)
Pump Flow L/min (gpm)	100(26.4)

AXLES

Front	Fixed
Oscillating Rear	10 degrees

BRAKE SYSTEM

Service Brakes	Hydrostatic dybamic breaking, Pneumatically assisted, hydraulically actuaded, four wheels disk brake for instant response
Parking Brake	Manually activated, Drum mounted on transmission output shaft

WHEELS

Front Drum Width mm (ft)	1,040(3.4)
Rear Drum Width mm (ft)	835(2.7)
Drum Diameter mm (ft)	1,500(4.9)
Blades per Wheel, Front	50
Blades per Wheel, Rear	40

Equipment specifications and images may change without notice from Rhino Equipment Group Inc.

BLADE	
Type	Straight
Blade Width mm (ft)	3,000(9.8)
Blade Height mm (ft)	1,650(5.4)
REFILL CAPACITIES L (gal)	
Fuel Tank	350(92)
Cooling	45(12)
Engine Oil	30(8)
Transmission	40(11)
Final Drives (each)	30(8)
Hydraulic Tank	110(29)
OPERATING WEIGHT	
Machine Weight kg (lbs)	23,000(50,706)

Compactor operating information is based on machine with identified linkage and standard equipment, full fuel tank, and 79-kg (175 lb.) operator. This information is affected by changes in type of drums, ballast, and different attachments.

Equipment specifications and images may change without notice from Rhino Equipment Group Inc.

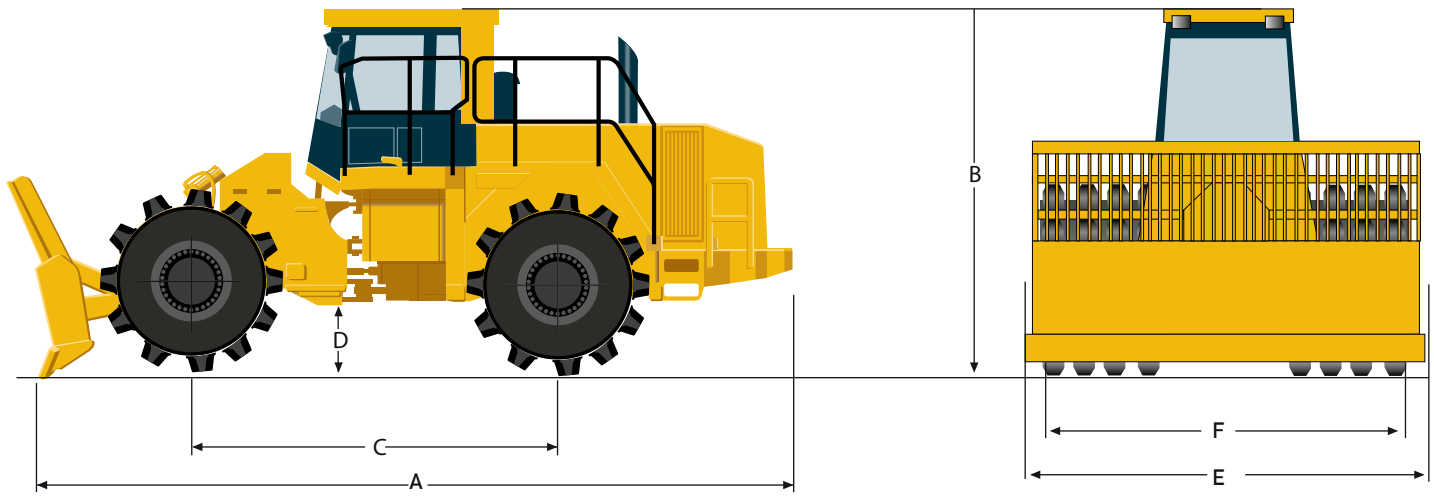

MACHINE DIMENSIONS

A Overall Length mm (ft)	7,355(24.1)
B Max. Machine Height mm (ft)	3,600(11.8)
C Wheelbase mm (ft)	3,350(11.0)
D Ground Clearance mm (ft)	435(1.4)
E Overall Width mm (ft)	3,000(9.8)
F Width Over Tires	2,910(9.5)
Outside Turning Radius mm (ft)	6,700(22.0)
Articulation Angle	30 degrees
Gradeability	45 degrees

OPTIONS

ROPS/FOPS Cab, Infrared Outside Camera, Tilt Cylinder for Blade, A/C, U-Blade, Semi-U Blade, Soil Compaction Drums Tier 3, Tier 4 engine.

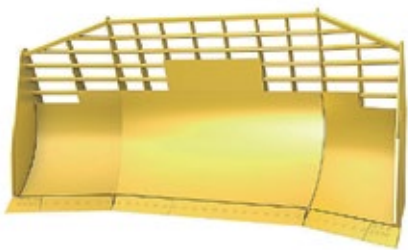

Landfill Blades

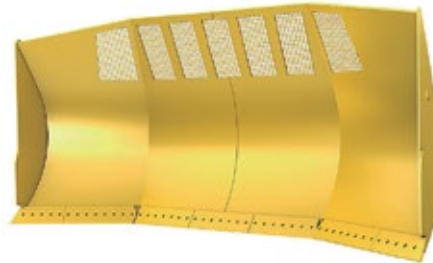

Woodchip Blades

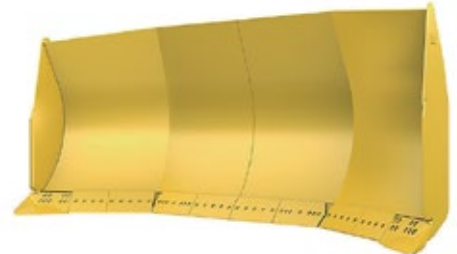

Coal U Blades

Equipment specifications and images may change without notice from Rhino Equipment Group Inc.