



# REX130

EXCAVATOR



# Unprecedented precision and ease of operation.



This Rhino excavator is loaded with enhancements that not only increase productivity and uptime, but lower daily operating costs, too. A high-efficiency “on-demand” cooling system, advanced multifunction monitor, and productivity modes to allow you to choose your digging style headline the long list of advances.



1. Level climate-control system with automotive-style adjustable louvers helps keep the glass clear and the cab comfortable.
2. LCD monitor provide intuitive access to a wealth of information and functions.
3. Ergonomically correct short-throw pilot levers provide smooth, predictable fingertip control with less movement or effort.



# Highly efficient, highly productive

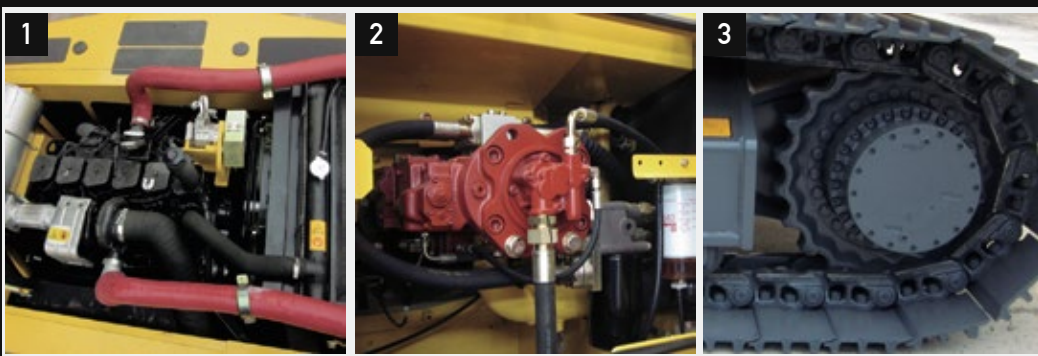

With more arm force, bucket breakout force, and lift capacity, the REX130 is an impressive performer. And if you're looking to put even more work within reach, add any of the many options and attachments that increase machine capability and expand your profit potential.

1. Reliable and durable Cummins diesel engine, more efficient with low maintenance costs.
2. Generous flow, and swing torque help speed cycles. So you can do your best to stay on schedule or ahead of the weather.
3. With large idlers, rollers, and struted links, the sealed and lubricated undercarriage delivers long and reliable performance.



## ENGINE

Engine Make/ Engine Model	Cummins / 4BT3.9-C110 or Rhino
Emission Rating (optional)	Tier 2 (Tier 3, Tier 4)
Cylinders	4
Displacement L (cu. In)	3.9(238)
Net Power kW (Hp) @2,200 rpm	86(115)
Fuel System	Direct Injection
Aspiration	Turbocharged, air-to-air charge air cooler

## COOLING

Fan Drive	Belt driven
-----------	-------------

## POWERTRAIN

Type	Dual speed mode for tracks on-dash one-button activation
Maximum Travel Speeds	
Low	3(2)
High	5(3)
Drawbar Pull kg (lb)	8,000(17,637)

## HYDRAULICS

Type	Open center, load sensing; two variable-displacement axial-piston pumps
Pressure Mpa (psi)	31(4,554)
Max. Flow L/min (gpm) (each)	128(34)
Power Boost Mpa (psi)	34(4,975)
Control	Pilot levers, low-effort hydraulic controls with horn and boost buttons

## CYLINDERS

	Bore	Rod Diameter	Stroke
Boom (2) mm (in)	105(4.1)	70(2.8)	990(39.0)
Arm (1) mm (in)	115(4.5)	75(3.0)	1,175(46.3)
Bucket (1) mm (in)	95(3.7)	65(2.6)	885(34.8)

## ELECTRICAL

Number of Batteries	2
Voltage	24 Volts
Battery Capacity (each)	850 CCA
Alternator Rating	70 A
Lights	5 Front lights, 1 Rear lights

Equipment specifications and images may change without notice from Rhino Equipment Group Inc.



**UNDERCARRIAGE**

Carrier Rollers (each side)	2
Track Rollers (each side)	7
Shoes (each side) Triple Semi-Grousers	42
Track	
Adjustment	Hydraulic
Guides	Front Idler
Chain	Sealed and lubricated

**GROUND PRESSURE**

Triple Semi-Grouser (500mm) (20 in) Shoes Kpa (psi)	38(5.5)
---	---------

**SWING MECHANISM**

Speed	12.6 rpm
Torque Nm (lb-ft)	27,220(20,076)

**REFILL CAPACITIES L (gal)**

Fuel Tank	247(65)
Cooling System	14(4)
Engine Oil	11(3)
Hydraulic System	145(38)
Hydraulic Tank	90(24)
Swing Mechanism	0.5(0.1)
Final Drive Case (each)	2.6(0.7)

**OPERATING WEIGHTS**

With full fuel tank: 79 kg (175lb) operator; 0.53 m3 (0.7 cu. Yd), 370 kg (816 lb) general purpose bucket; 500 mm (20 in) shoes; and 2,500 mm (8.2 ft) arm

Base Weight kg (lb)	13,000(28,660)
Component Weights	
Undercarriage	
Triple Semi Grouser 500mm (20 in) Shoes kg (lb)	5,094(11,230)
One-Piece Boom kg (lb)	1,088(2,399)
Arm with Bucket Cylinder and Linkage	
2,500 mm (10 ft) kg (lb)	525(1,157)
Boom Lift Cylinders (2), Total Weight kg (lb)	186(410)
0.53 m3 (0.70 cu. Yd) Bucket kg (lb)	370(816)
Counterweight, Standard	2,450(5,401)

Equipment specifications and images may change without notice from Rhino Equipment Group Inc.

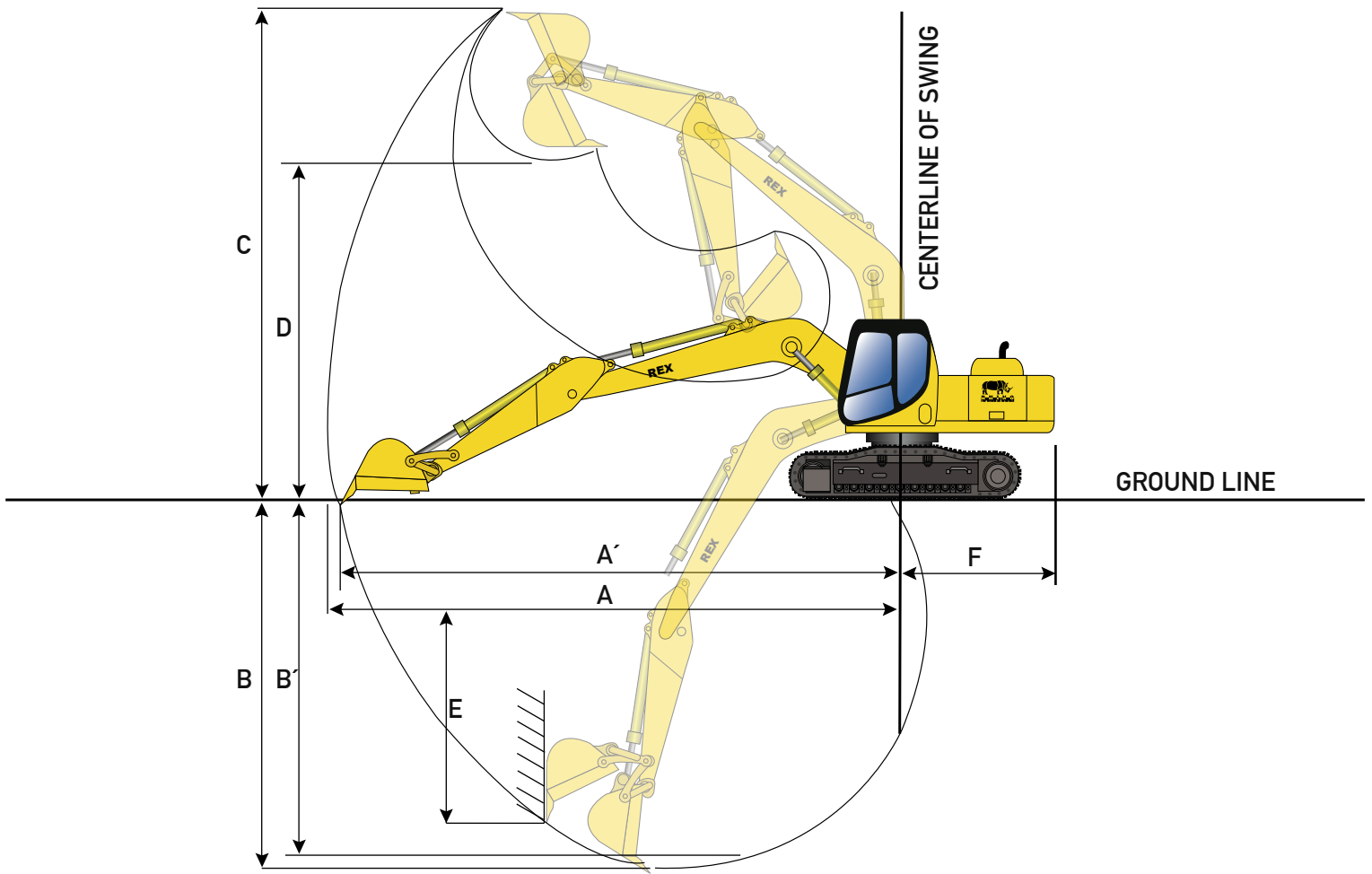

## OPERATING DIMENSIONS

Arm Length mm (ft)	2,500(8.2)
Arm Digging Force kN (lb)	64(14,388)
Bucket Digging Force kN (lb)	80(17,985)
Lift Over End at 15' Radius, Ground Level kg (lb)	5,420(11,949)
Lift Over End at 20' Radius, Ground Level kg (lb)	3,710(8,179)
Lift Over Side at 15' Radius, Ground Level kg (lb)	3,710(8,179)
Lift Over Side at 20' Radius, Ground Level kg (lb)	2,490(5,490)
A. Max. Reach mm (ft)	8,390(27.5)
A'. Max. Reach at Ground Level mm (ft)	8,180(26.8)
B. Max. Digging Depth mm (ft)	5,500(18.0)
B'. Max. Digging Depth at 2,440 mm (8 ft) Flat Bottom mm (ft)	5,305(17.4)
C. Max. Cutting Height mm (ft)	8,630(28.3)
D. Max. Dumping Height mm (ft)	6,180(20.3)
E. Max. Vertical Wall mm (ft)	4,940(16.2)
F. Tail Swing Radius mm (ft)	2,015(6.6)

Equipment specifications and images may change without notice from Rhino Equipment Group Inc.

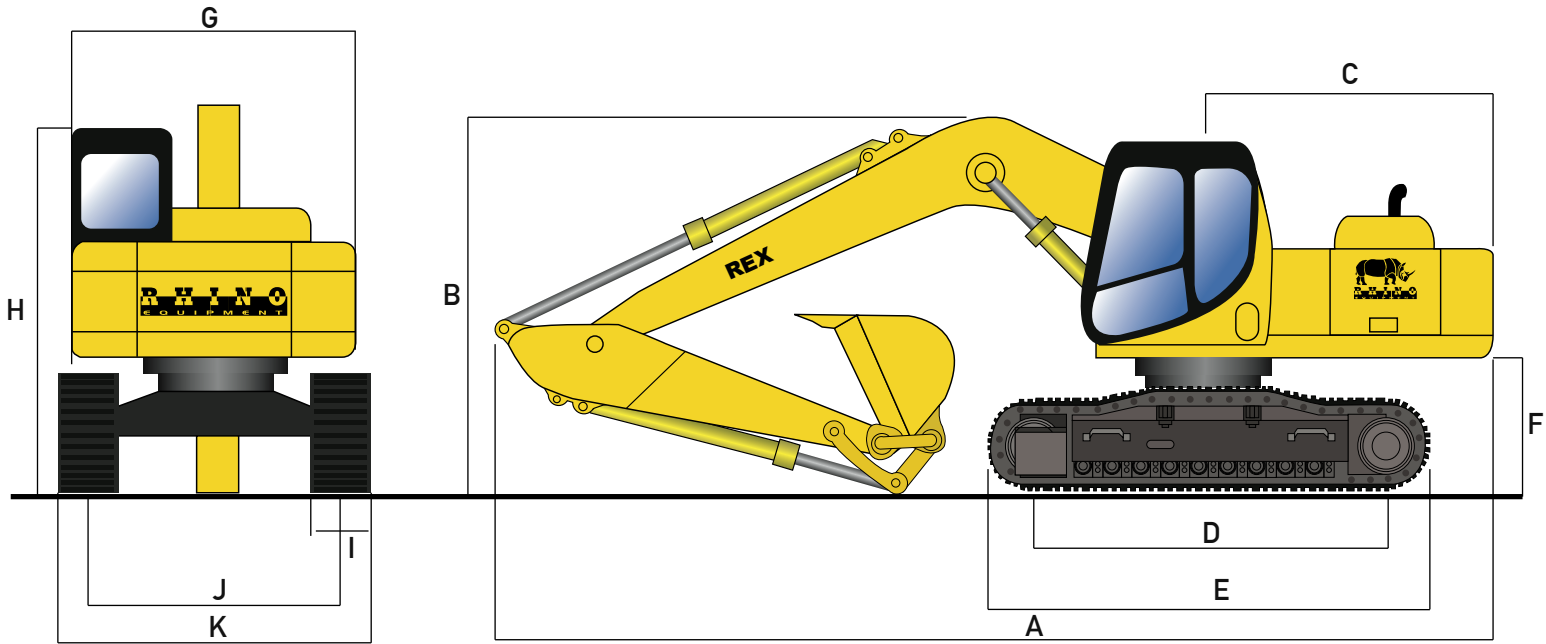

## MACHINE DIMENSIONS

A. Overall Length with 2,500 mm (8 ft) Arm mm (ft)	7,600(24.9)
B. Overall Height with 2,500 mm (8ft) Arm mm (ft)	2,780(9.1)
C. Swing Radius mm (ft)	2,015(6.6)
D. Length of Track on Ground mm (ft)	2,750(9.0)
E. Undercarriage Length mm (ft)	3,486(11.4)
F. Counterweight Clearance mm (ft)	870(2.9)
G. Upperstructure Width mm (ft)	2,490(8.2)
H. Cab Height mm (ft)	2,813(9.2)
I. Track Width mm (in)	500(19.7)
J. Gauge Width mm (ft)	1,960(6.4)
K. Overall Width with Triple Semi-Grouser 500 mm (20 in) Shoes mm (ft)	2,460(8.1)

## ATTACHMENTS

Rhino excavators come standard with the hydraulic line for attachments. Attachments include hydraulic hammers, thumb cutters, and many more.

Rhino Hydraulic Hammer Match: 714BE



Rhino Excavators can come with different types of buckets depending on work requirements

Equipment specifications and images may change without notice from Rhino Equipment Group Inc.

## OPTIONS

Rhino Excavators can come with different options like: Tier2, Tier3, Tier4 Engine, Close cab, Rock bucket, Trench bucket, Thumb cutters, and many more according to work requirements.

## ATTACHMENTS

Rhino Excavators come standard with the hydraulic line for attachments.

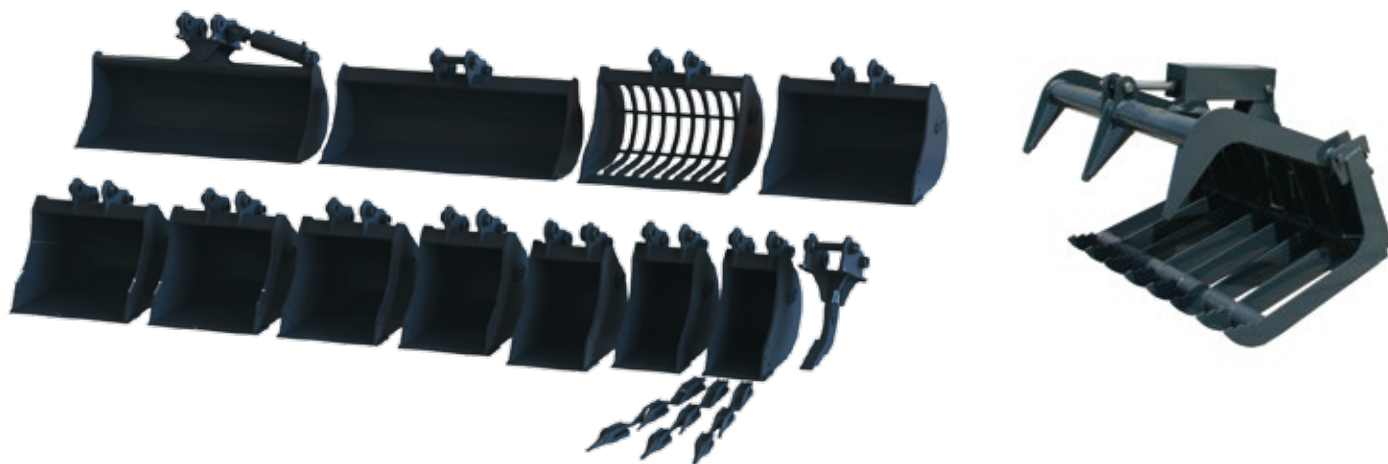

Many options buckets



Hydraulic hammers



Trenchers



Augers

and many more...

Equipment specifications and images may change without notice from Rhino Equipment Group Inc.