

ENGINE

Power adjusted	ISO 14396	HP - kW	130 (95,8)
Regimen adjusted		rpm	2200
Numbers of cylinders		4 charged intercooler	
Injection		Direct and electronic	
Intake		Turbo	
Displacement		cc.	4400
Cooling		water	
Air filter with double protection		dry	
Electrical equipment		volt	12
Free maintenance battery		Ah	132
Self regulated alternator		W	1140
Fuel tank capacity		l	150
Water radiator		Hydraulic fan	

TRANSMISSION

High-pressure, closed-loop hydrostatic transmission, with automatic adjustment of power, axial pistons pump and engine at variable displacement
Inching pedal control for traction regulation, modulating, integrated in the service brake pedal

Automatic working speed selection.

n° 4 forward and backward speeds: 2 working speeds + 2 transfer speeds with electronic controls at the joystick

SPEED

		1 st	2 nd automatic
Working speed (with 17,5 R25 tyres)			
Forwards	Km/h	0 ÷ 4	0 ÷ 13
Backwards	Km/h	0 ÷ 4	0 ÷ 13
Travel speed (with 17.5 R25 tyres)			
Forwards	Km/h	0 ÷ 11	0 ÷ 40
Backwards	Km/h	0 ÷ 11	0 ÷ 40

AXLES

With epicycloids reduction on all four driving wheels.

Front axle: rigid with automatic proportional self-locking differential.
Rear axle: oscillating of a 25° total range steering and automatic proportional self-locking differential.

BRAKES

Duty brakes: with hydraulic control on all four wheels at multiple disks under oil bath integrated in the axles, with 2 independent circuits.
Parking brakes: electro-hydraulic automatic negative brake, acting on the front and rear axles.

HYDRAULIC SYSTEM

Composed by: hydraulic gear pump. Modular distributor with main relief valve, double pump + fan-drive, shock-proof, anticavitation valve and unloading valve for the secondary pump discharge. Pressurised circuit.

Max pump capacity	134l
Max pump pressure	250 kg/cm ²
Loader lifting cylinder	Bore x Stroke 100x700 mm
Loader bucket cylinder	Bore x Stroke 120x490 mm
Oil tank capacity	80l
Heat exchanger	hydraulic fan

STEERING

Servoassisted, with hydroguide and articulated chassis. Total steering angle of 80°. The hydraulic system is "Load Sensing" equipped, with valve on the primary pump.

TYRES

Standard:	17,5 x 25 radial
Optional:	15,5 x 25 radial
Optional:	500/70 R24 radial
Other models on request.	

LOADER

Single electronic servo control lever for arm and bucket.
Electronic bucket levelling and electronic parallelism with forks.
Telescopic boom, with 1200 mm extension

DIMENSIONS

Wheelbase	2750 mm
Front and rear track width	1800 mm
Extrnal tyres width	(with 17.5x25) 2260 mm

STANDARD EQUIPMENT

- > Loader servo control
- > Automatic proportional self-locking differential on front and rear axle
- > Inching control on brake pedal (transmission speed regulation)
- > Antipollution tank plugs
- > Bucket with screwed teeth
- > Reverse motion alarm
- > Battery disconnecting switch
- > Front and rear work lights
- > Rotating lamp with magnetic fixing
- > Shock absorbing and regulating "Deluxe" seat, with safety belt
- > Regulating steering wheel
- > Bucket electronic levelling
- > Floating system
- > Heating plant
- > Air filter in aspiration from outside
- > Rotoform front mudguards
- > Tool box
- > Use and maintenance manual, spare parts catalogue
- > Accessories for road circulation
- > Italian road homologation for daily and night circulation
- > CE Certification

OPTIONAL EQUIPMENT

- > Hydraulic quick bucket connection
- > Universal forks
- > Enlarged bucket
- > Extra enlarged bucket for light material
- > Enlarged bucket for light material having higher unloading
- > 4:1 multipurpose bucket
- > Paper and branches grab
- > Bucket with side unloading
- > Mixer bucket
- > Wood grab
- > Snow blade or snow plough
- > Front rotating brush with bucket
- > Teeth blade
- > Asphalt concrete milling
- > Inching control manually operated
- > Electronic weighting system
- > Air conditioning
- > Radio
- > Theft protection
- > Ride control
- > Floating element
- > Empowered battery 12V 185 Ah

For other accessories and equipment for characteristics and dimension, please see the "equipment catalogue".

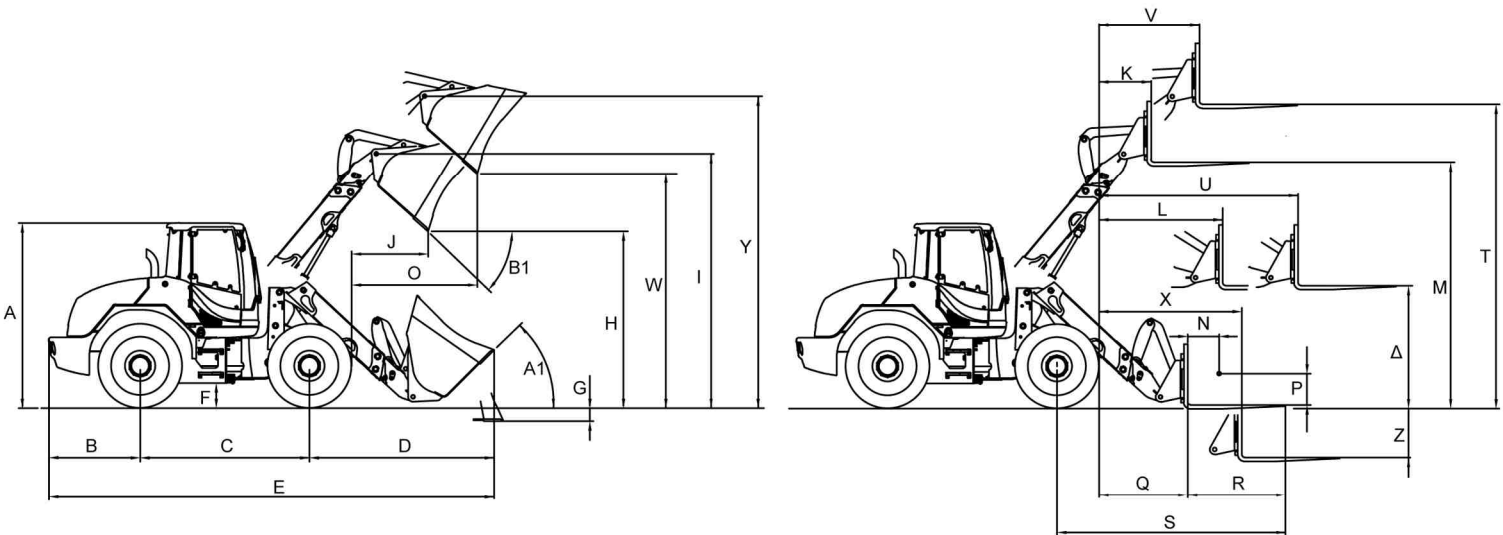

Date according to bucket type PT 192 with 17,5 X 25 tyres		STD.	ENLARGED	EXTRA ENLARGED	4 : 1
Capacity heaped	m ³	1,60	1,8	2,2	1,50
Material density	kg/m ³	1800	1500	1200	1800
Tipping load with aligned machine (ISO 14397) retracted boom	kg	5560	5460	5347	5550
Tipping load in max articulated position (40°) (ISO 14397) retracted	kg	5075	4983	4880	5065
Tipping load with aligned machine (ISO 14397) extended boom	kg	3252	3184	3100	3142
Tipping load in max articulated position (40°) (ISO 14397) extended	kg	2968	2906	2830	2952
Lifting capacity at max height retracted boom	kN	42,95	41,95	39,42	42,75
Lifting capacity at max height extended boom	kN	27,92	26,92	25,42	27,76
Breakout force	kN	86,63	82,29	74,80	86,63
E Total length	mm	6707	6737	6820	6707
Bucket width	mm	2400	2450	2450	2400
Rotation diameter	mm	11640	11690	11840	11640
G Digging depth	mm	142	142	142	142
H Dump height 45° retracted	mm	3136	3103	3004	3155
W Dump height 45° extended	mm	4000	3967	3868	4020
J Reach at max height retracted	mm	964	1001	1114	942
O Reach at max height extended	mm	1874	1912	2024	1854
Operating weight	kg	9300	9400	9600	9350

PT 192 17,5 X 25 tyres	
A	2890 mm
B	1320 mm
C	2750 mm
F	400 mm
e	2830 mm
β	5165 mm
I	4017 mm
Y	4936 mm
K	816 mm
L	1961 mm
M	3807 mm
N	500 mm
P	500 mm
Q	1401 mm
R	1200 mm
S	3275 mm
T	4727 mm
U	3161 mm
V	1587 mm
Z	886 mm
X	2278 mm
a	1832 mm

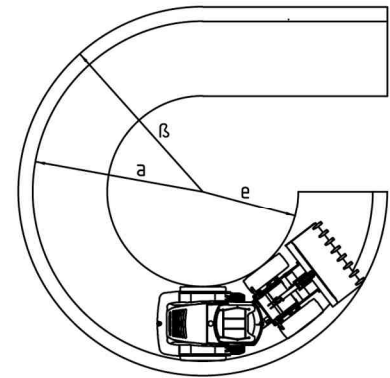

Data with universal forks Centre of gravity 500 mm		
Operative load with retracted forks EN 474-3 (80%)	kg	3245
Operative load with retracted forks EN 474-3 (60%)	kg	2434
Operative load with extended forks EN 474-3 (80%)	kg	2300
Operative load with extended forks EN 474-3 (60%)	kg	1724

PALOAD is a mark produced by Palazzani industrie S.p.A.
NC 358 A 13 Technical sheet PT 192 english



COMPANY WITH QUALITY MANAGEMENT
SYSTEM CERTIFIED BY DNV
= ISO 9001:2008 =

CE MACHINE IN CONFORMITY TO THE NEW MACHINES' STANDARDS
We reserve the right to change technical data, so all characteristics are purely indicative. Pictures don't show necessarily the machine in standard version.