

# PC400HD-5

**HEAVY DUTY  
HYDRAULIC EXCAVATOR**



Model shown may include optional equipment

## ***KOMATSU: The Quality is Standard.***

**FLYWHEEL HORSEPOWER: 276 HP @ 2000 RPM. BUCKET CAPACITY: .96-2.29 m<sup>3</sup> (1.25-3.00 yd<sup>3</sup>).  
OPERATING WEIGHT: 44560 kg (98,230 lb).**

- Working mode selection system matches machine performance to actual job conditions
- OLSS system conserves fuel by preventing neutral, fine control and relief losses
- "Power max" button temporarily boosts digging forces for added power in tough situations
- Autodecelerator lowers engine speed whenever the work equipment and travel controls are in neutral for additional fuel savings
- Hi-Lo travel speed system automatically selects the correct travel speed depending on ground conditions and operator selection
- Merged circuits reduce cycle times
- Straight travel circuit assures straight travel, even during simultaneous operations
- Spacious, well-ventilated cab, excellent visibility and adjustable wrist controls add to the operator's comfort and productivity
- Adjustable electronic monitor and control console puts all control and monitoring functions at your fingertips
- Long track length and a wide variable track gauge provide for greater stability, increased lifting capacities and easy transport
- High ground clearance provides greater accessibility to forestry and other remote, rough ground applications
- Heavy-duty undercarriage means excellent durability even in the roughest applications

# The New Frontier of Technology

## UNEQUALLED PERFORMANCE AND FUEL ECONOMY

### Working Mode Selection System

This system allows the operator to match machine performance and economy to the task at hand by selecting either the "Heavy Duty Operations," "General Operations," "Finishing Operations" or "Lifting Operations" mode. Simply select the appropriate working mode and the microcomputer does the rest.

### Pump and Engine Mutual Control System

A microprocessor automatically varies engine speed and pump output for maximum fuel efficiency without sacrificing productivity.

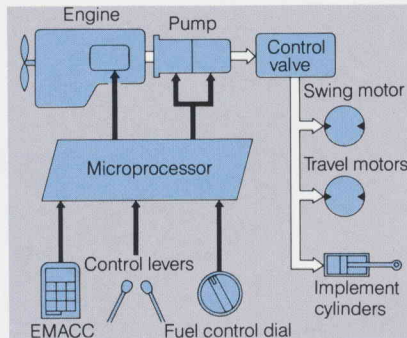

### Electronic Monitor and Control Console (EMACC)

The EMACC puts all system controls and display functions within easy view and reach of the operator. The console can also be rotated through three positions to provide the best, glare-free viewing angle.

#### The EMACC Consists of:

- Working Modes
- Power Modes: Three modes (H, S and L) are automatically set in accordance with the working mode. Manual reset is also possible.
- Autodeceleration
- Monitor: constantly checks machine's condition
  - Pre-start level checks
  - Fuel gauge
  - Coolant temperature gauge
  - Caution items: coolant level and temperature, fuel level, oil pressure, and charge system
- Lo-Hi travel speed selector
- Swing lock indicator
- Wiper controls: intermittent or continuous
- Heater fan control



Power max. button

**"Power Max" Button**  
Located on top of the left hand control lever, the "power max" button temporarily increases digging forces for added power in tough digging situations.



# The New Frontier of Quality



## Quality Improvements Include:

- Added filters and radiator dust-resistant screening to keep the hydraulic system clean and cool.
- Double lock electronic connectors and in-cab mounted electronic microprocessor provide increased reliability and protection from the elements.

## Automatic Warm-Up System

Engine speed is automatically controlled by the microprocessor when coolant temperature is low for fast, fuel efficient and reliable engine warm-up.

## Engine Overheat Prevention

Should the coolant temperature rise above desired levels, pump output and engine speed are reduced, preventing damage to the engine.

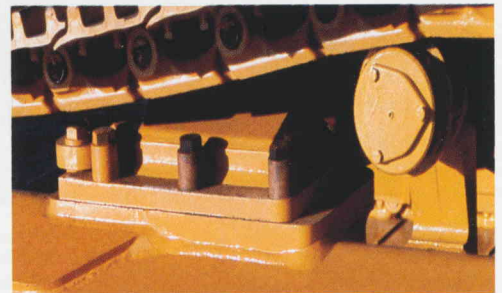

Variable Track Gauge

## Variable Track Gauge

For shipping convenience, the gauge of the track and thus the overall width, can be decreased. This enhances the ability to transport the machine through tunnels, into remote mountain areas, and through many other confined areas.

## Heavy Duty Undercarriage

Several modifications and enhancements have been made to the PC400LC-5 undercarriage. This has resulted in a stronger, more durable undercarriage ideally suited for heavy-duty applications.

## Other Performance-Proven Features

- OLSS (Open-Center Load Sensing System) reduces hydraulic losses.
- Autodeceleration boosts fuel economy.
- Swing holding brake makes working on slopes much easier.
- Car-like operator's cab.
- X-leg frame for excellent stability.
- Merged circuits shorten cycle times.
- Straight travel circuits facilitate simultaneous work equipment/travel operations.

## EASY AND COMFORTABLE OPERATION

### Automatic Hi-Lo Travel Speed

Travel speed is automatically shifted to either "Hi" or "Lo," depending on ground conditions and operator selection.

### Fuel Control Dial

The easy to use dial makes adjusting the engine speed quick and effortless.

### Engine Key Stop

To stop the engine, simply turn the ignition key to off.

### Spacious Cab

The roomy, efficient cab design has a large glass area for excellent visibility, as well as sliding front and side windows for cross ventilation.

### Adjustable Wrist Control Levers

Unitized wrist control levers and arm rests can be adjusted through three work positions for maximum operator comfort. The proportional pressure wrist controls reduce operating effort while assuring precise work equipment operations.

### Adjustable Operator's Seat

The fully adjustable suspension seat provides outstanding comfort.

### Boom Lock Valve

The boom circuit is equipped with a boom holding valve to prevent hydraulic drift of the work equipment.

### Swing Lock

The swing can be locked for transport simply by flicking a switch.

### High Ground Clearance

Travel is easy, even on rough ground, due to the increased ground clearance.

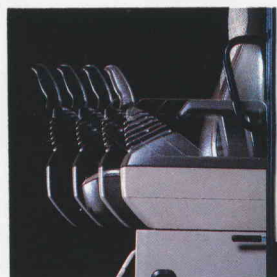

Adjustable wrist control lever

# SPECIFICATIONS



## ENGINE

Komatsu SA6D125 4-cycle, water-cooled, and turbocharged diesel engine with 6 cylinders, 125 mm (4.92") bore x 150 mm (5.90") stroke and 4.89 ltr (673 in<sup>3</sup>) piston displacement. Flywheel horsepower ..... **276 HP @ 2000 RPM**  
The engine features direct injection for fuel economy, a mechanical all-speed governor, forced lubrication with a full flow filter, dry-type air cleaner with dust indicator and automatic dust evacuator, 24 V/7.5 kw starting system with 25A alternator, 2 x 12V/150 Ah batteries.



## HYDRAULIC SYSTEM

Two variable capacity piston pumps and independent swing operation assure smooth compound movements of the work equipment. The Pump and Engine Mutual Control (PEMC) system controls the engine speed and pump output for maximum fuel efficiency and productivity. The Open-center Load Sensing System (OLSS) controls the pumps for efficient use of engine power, reduced hydraulic losses during operation, and low fuel consumption.

Two variable-capacity piston pumps power boom, arm, bucket, swing and travel circuits. One gear pump powers pilot control circuits.

**Pump capacities** (discharge flow @ 2000 engine RPM):  
Piston ..... 315 ltr (83 U.S. gal) min x 2  
Gear ..... 92 ltr (24 U.S. gal) min

### Hydraulic motors:

Travel ..... Two axial piston motors with parking brake  
Swing ..... One axial piston motor with swing holding brake

### Relief valve settings:

Implement circuits ..... 325 kg/cm<sup>2</sup> (4,620 psi)  
Swing circuits ..... 260 kg/cm<sup>2</sup> (3,700 psi)  
Pilot circuits ..... 30 kg/cm<sup>2</sup> (430 psi)  
Travel circuits ..... 325 kg/cm<sup>2</sup> (4,620 psi)

### Control valves:

4-spool and 5-spool valves with a service valve

### No. of cylinders — bore x stroke:

Boom ..... 2-160 mm x 1570 mm (6.3" x 5'2")  
Arm ..... 1-185 mm x 1820 mm (7.3" x 6'0")  
Bucket ..... 1-160 mm x 1270 mm (6.3" x 4'2")



## STEERING

Steering/traveling controls are activated with either hand levers or foot pedals. Pushing both levers (or pedals) moves machine forward. Pulling them back makes machine go into reverse. Setting one lever (or pedal) in neutral and the other in forward enables machine to make a pivot turn. Pushing one forward while pulling the other backward makes machine counterrotate on the spot.



## DRIVES

Fully hydrostatic drive with each track powered by an axial piston two-speed motor. Power goes through a double-reduction planetary gear to the track. Automatic Hi-Lo travel.  
Maximum drawbar pull ..... 32500 Kg (71,650 lb)  
Maximum travel speed, high ..... 5.5 Km/h (3.4 MPH)  
Maximum travel speed, low ..... 3.1 Km/h (1.9 MPH)



## BRAKES

Each travel motor is equipped with a brake valve that lessens shock when applied, and limits speed during descent. The wet, multiple-disc brakes actuate on the final-drive input shaft and automatically lock when the travel/steering levers and/or pedals are in neutral.



## SWING SYSTEM

The swing system is powered by a hydraulic driven motor through spur and planetary gears. Single-row, shear type ball bearings with induction-hardened internal gears are built into the swing circle. Grease-bathed swing pinion, electric swing lock and swing holding brake are provided. Swing speed is proportional to swing control lever stroke.

Max. swing speed ..... 9.3 RPM  
Tail-swing radius ..... 3430 mm (11'3")  
Min. swing radius ..... 4660 mm (15'3")  
(work equipment, fully retracted)



## UNDERCARRIAGE

X-leg type center frame is integrally welded with reinforced box-section track frames. Variable track gauge system allows reduction in track gauge for easy shipping without sacrificing operating stability. The design includes sealed tracks, lubricated rollers and idlers, hydraulic track adjusters with shock absorbing springs, and assembled track-type tractor shoes with triple grousers.

Shoe width ..... 750 mm (29.5")  
Grouser height ..... 26 mm (1")  
Number of shoes (each side) ..... 52  
Number of carrier rollers (each side) ..... 2  
Number of track rollers (each side) ..... 10  
Ground pressure ..... 0.63 kg/cm<sup>2</sup> (8.96 psi)



## SERVICE REFILL CAPACITIES

Fuel tank ..... 550 ltr (145 U.S. gal)  
Coolant ..... 32.5 ltr (8.6 U.S. gal)  
Engine ..... 34.1 ltr (9 U.S. gal)  
Final drive (each side) ..... 11 ltr (3 U.S. gal)  
Swing drive ..... 22 ltr (6 U.S. gal)  
Hydraulic oil ..... 255 ltr (67 U.S. gal)



## OPERATING WEIGHT

Including 7060 mm (23'2") one-piece boom, 3380 mm (11'1") arm, 1.82 m<sup>3</sup> (2.38 yd<sup>3</sup>) ESCO STDP backhoe bucket, 750 mm (29.5") triple grouser shoes, operator, lubricant, coolant and full fuel tank ..... 44560 kg (98,230 lb)





## DIMENSIONS

		2.4 m (7'10") arm	2.9 m (9'6") arm	3.38 m (11'1") arm	4.0 m (13'1") arm	4.8 m (15'9") arm
A	Overall length	11765 mm (38'7")	11750 mm (38'7")	11690 mm (38'4")	11705 mm (38'5")	11565 mm (37'11")
B	Length on ground (transport)	8425 mm (27'8")	7410 mm (24'4")	6660 mm (21'10")	6265 mm (20'7")	5975 mm (19'7")
C	Overall height (to top of boom)	3660 mm (12')	3680 mm (12'9")	3545 mm (11'8")	3805 mm (12'6")	4360 mm (14'4")

D	Overall width	3620 mm (11'11")
D	Overall width (transport)*	3120 mm (10'3")
E	Overall height (to top of cab)	3220 mm (10'7")
F	Ground clearance, counterweight	1320 mm (4'4")
G	Min. ground clearance	645 mm (2'1")
H	Tail swing radius	3430 mm (11'3")
I	Length of track on ground	4340 mm (14'3")
J	Track length	5355 mm (17'7")
K	Track gauge	2870 mm (9'5")
K	Track gauge - Undercarriage retracted	2380 mm (7'10")
L	Width of crawler	3620 mm (11'11")
L	Width of crawler - Undercarriage retracted	3120 mm (10'3")
M	Shoe width	750 mm (30")
N	Grouser height	36 mm (1.4")
O	Machine cab height	2750 mm (9'1")
P	Machine cab width	2960 mm (9'9")
Q	Distance, swing center to rear end	3360 mm (11')

\*Variable gauge retracted

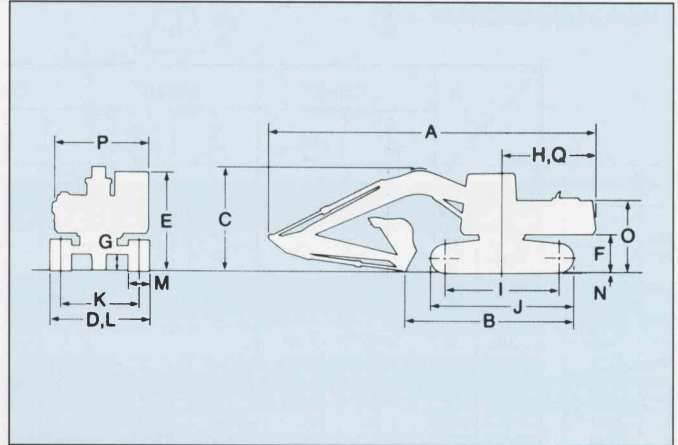

## WORKING RANGE

		2.4 m (7'10") arm	2.9 m (9'6") arm	3.38 m (11'1") arm	4.0 m (13'1") arm	4.8 m (15'9") arm
A	Max. digging height	10305 mm (33'10")	10315 mm (33'10")	10930 (35'10")	11055 mm (36'3")	11515 mm (37'9")
B	Max. dumping height	7070 mm (23'2")	7110 mm (23'4")	7585 mm (23'11")	7740 mm (25'5")	8170 mm (26'10")
C	Max. digging depth	6780 mm (22'3")	7280 mm (23'11")	7755 mm (25'5")	8380 mm (27'6")	9190 mm (30'2")
D	Max. vertical wall digging depth	5310 mm (17'5")	5655 mm (18'7")	6825 mm (22'5")	7255 mm (23'10")	8190 mm (26'10")
E	Max. digging depth of cut for 8' level	6580 mm (21'7")	7090 mm (23'3")	7615 mm (25'0")	8250 mm (27'1")	9075 mm (29'9")
F	Max. digging reach	11050 mm (36'3")	11430 mm (37'6")	12015 mm (39'5")	12545 mm (41'2")	13345 mm (43'9")
G	Max. digging reach at ground level	10830 mm (35'6")	11220 mm (36'10")	11810 mm (38'9")	12350 mm (40'6")	13165 mm (43'2")
H	Min. swing radius	4750 mm (15'7")	4730 mm (15'6")	4660 mm (15'3")	4710 mm (15'5")	4785 mm (15'8")
Bucket digging force		22500 Kg (49,600 lb/221 kN)	22400 Kg (49,380 lb/220 kN)	22600 Kg (49,820 lb/222 kN)	22400 Kg (49,380 lb/220 kN)	22300 Kg (49,160 lb/219 kN)
Arm crowd force		25800 Kg (56,880 lb/253 kN)	22900 Kg (50,490 lb/224 kN)	19300 Kg (42,550 lb/189 kN)	17300 Kg (38,140 lb/170 kN)	15200 Kg (33,510 lb/149 kN)

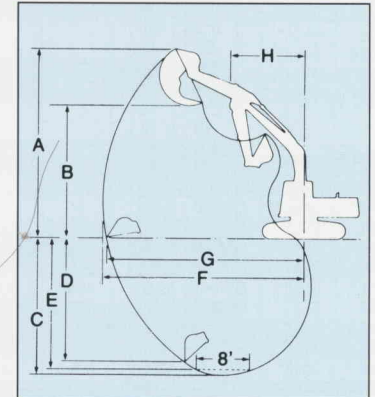

## BUCKETS

TYPE	Capacity m <sup>3</sup> (yd <sup>3</sup> ) SAE, PCSA heaped	Width mm (in)		Weight Kg (lb)	No. of Teeth	ARMS				
		Outside Lip	With side cutters (Komatsu) With wear shrouds (ESCO)			2.4 m (7'10")	2.9 m (9'6")	3.38 m (11'1")	4.0 m (13'1")	4.8 m (15'9")
KOMATSU Mid-Heavy Duty	1.15 (1.50)	838 (33)	1005 (40)	1179 (2,600)	4	○	○	○	○	○
	1.38 (1.75)	965 (38)	1132 (45)	1335 (2,945)	5	○	○	○	○	○
	1.63 (2.13)	1143 (45)	1371 (55)	1397 (3,080)	5	○	○	○	○	□
ESCO STDP	1.25 (1.63)	915 (36)	965 (38)	1150 (2,531)	4	○	○	○	○	○
	1.53 (2.00)	1065 (42)	1120 (44)	1260 (2,781)	5	○	○	○	○	○
	1.82 (2.38)	1220 (48)	1270 (50)	1350 (2,977)	5	○	○	○	○	□
	2.10 (2.75)	1370 (54)	1420 (56)	1550 (3,419)	6	○	○	○	△	X
	2.29 (3.00)	1525 (60)	1575 (62)	1660 (3,660)	6	○	□	□	X	X
ESCO HDP	1.25 (1.63)	915 (36)	965 (38)	1440 (3,178)	4	○	○	○	○	○
	1.53 (2.00)	1065 (42)	1120 (44)	1585 (3,491)	5	○	○	○	○	□
	1.82 (2.38)	1220 (48)	1270 (50)	1695 (3,737)	5	○	○	○	○	□
	2.10 (2.75)	1370 (54)	1420 (56)	1840 (4,055)	6	○	○	○	△	X
	2.29 (3.00)	1525 (60)	1575 (62)	1950 (4,303)	6	○	□	□	X	X
ESCO HDC	0.96 (1.25)	760 (30)	865 (34)	1245 (2,740)	4	○	○	○	○	○
	1.15 (1.50)	840 (33)	940 (37)	1365 (3,005)	4	○	○	○	○	○
	1.34 (1.75)	990 (39)	1090 (43)	1425 (3,145)	4	○	○	○	○	○
	1.62 (2.12)	1145 (45)	1245 (49)	1630 (3,598)	5	○	○	○	○	□

○ - Can be used with a material weight up to 3,040 lb/yd<sup>3</sup>  
 □ - Can be used with a material weight up to 2,520 lb/yd<sup>3</sup>

△ - Can be used with a material weight up to 2,020/yd<sup>3</sup>  
 X - Not useable

# PC400HD-5

Equipped with 750 mm (29.5") triple grouser shoes and a 1.82 m<sup>3</sup> (2.38 yd<sup>3</sup>), 1350 kg (2,977 lb) ESCO STDP bucket with wear shrouds and teeth.

## HYDRAULIC EXCAVATOR

### Lifting Capacity

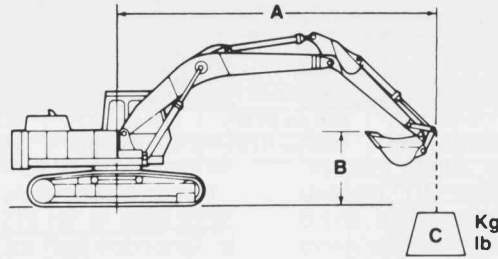

- A — Reach from swing centerline
- B — Bucket hook height
- C — Lifting capacities
- Rating over front
- Rating over side or 360 degrees
- Rating at maximum reach

A \ B	1.5m/5'		3.0m/10'		4.6m/15'		6.1m/20'		7.6m/25'		9.1m/30'				
<b>Arm</b>  	7.6m 25'	Kg lb							*8640 19070	*8640 19070			*8590 18870	8290 18270	
	6.1m 20'	Kg lb					*10290 22770	*10290 22770	*8890 19770	8890 19570			*8390 18470	6790 14970	
	4.6m 15'	Kg lb			*15840 34970	*15840 34970	*11690 25870	*11690 25870	*9640 21270	8540 18870	*8440 18670	6240 13770	*8340 18370	5990 13170	
	3.0m 10'	Kg lb					*12990 28670	*12990 24870	*11290 22970	*8190 18070	*8740 19370	6090 13370	*8390 18470	5540 12270	
	1.5m 5'	Kg lb					*14140 31170	10840 23970	*10990 24170	7840 17270	*8990 19870	5890 13070	*8490 18770	5440 11970	
	0m 0'	Kg lb					*14340 31670	10540 23270	*11140 24570	7640 16770	*7940 19770	5790 12770	*8640 18970	5590 12270	
	-1.5m -5'	Kg lb			*17790 39270	16440 36170	*13790 30470	10490 23070	*10790 23770	7540 16670			*8690 19170	6040 13370	
	-3.0m -10'	Kg lb		*18790 41370	*18790 41370	*15690 34570	*15690 34570	*12390 27270	10640 23370	*9540 20970	7640 16870			*8640 19070	7090 15570
	-4.6m -15'	Kg lb				*12240 26970	*12240 26970	*9440 20870	*9440 20870					*8090 17870	*8090 17870
	-6.1m -20'	Kg lb													
	<b>Arm</b>  	7.6m 25'	Kg lb							*8040 17700	*8040 17700			*7890 17370	7540 16670
		6.1m 20'	Kg lb							*8490 18670	*8490 18670	*7790 17170	6440 14170	*7790 17170	6290 13870
4.6m 15'		Kg lb			*14690 32370	*14690 32370	*11090 24470	*11090 24470	*9190 20270	8640 19070	*8090 17870	6290 13870	*7790 17370	5590 11470	
3.0m 10'		Kg lb					*12690 27970	*12690 25770	*10040 22170	8240 18170	*8490 18770	6140 13470	*7890 17370	5190 11470	
1.5m 5'		Kg lb					*13840 30570	10990 24270	*10740 23770	7890 17370	*8840 19570	5940 13070	*8070 17670	5090 11170	
0m 0'		Kg lb					*18890 41670	16390 36170	*14340 31670	10640 23370	*11090 24470	7640 16870	*8940 19770	5790 12770	*8190 18070
-1.5m -5'		Kg lb		*13140 29070	*13140 29070	*18640 41070	16390 36170	*14090 31070	10490 23070	*10940 24170	7540 16570	*8590 18970	5740 12670	*8340 18470	5590 12270
-3.0m -10'		Kg lb		*20940 46170	*20940 46170	*16790 37070	16640 36670	*12940 28570	10540 23270	*10040 22170	7540 16670			8440 18670	6440 14170
-4.6m -15'		Kg lb		*17240 37970	*17240 37970	*13740 30370	*13740 30370	*10690 23570	*10690 23570					*8240 18170	*8190 18070
-6.1m -20'		Kg lb													
<b>Arm</b>  		7.6m 25'	Kg lb							*7990 17670	*7990 17670	*7390 16370	6540 14470	*5340 11770	*5340 11770
		6.1m 20'	Kg lb							*8840 19470	8790 19470	*7790 17170	6390 14170	*5390 11870	*5290 11670
	4.6m 15'	Kg lb					*10490 23170	*10490 23170	*8840 19470	8790 19470	*7790 17170	6390 14170	*5390 11870	5040 11070	
	3.0m 10'	Kg lb			*16990 37470	*16990 37470	*12190 26870	*11940 26270	*9740 21470	8390 18470	*8290 18270	6190 13670	*5690 12570	4740 10370	
	1.5m 5'	Kg lb			*19290 42570	*17240 37970	*13590 29970	11240 24770	*10540 23270	7990 17670	*8740 19270	5990 13170	*6140 13570	4790 10170	
	0m 0'	Kg lb					*18340 40470	16640 36670	*14290 31570	10740 23770	*11040 24370	7690 16970	*8940 19770	5840 12870	*6890 14690
	-1.5m -5'	Kg lb		*11590 25470	*11590 25470	*19290 42570	16490 36370	*14290 31470	10540 23270	*11090 24470	7540 16670	*8790 19470	5740 12670	*7690 16970	5040 11070
	-3.0m -10'	Kg lb	*13290 29370	*13290 29370	*17440 38370	*17440 38370	*17740 39170	16640 36670	*13490 29670	10540 23270	*10440 23070	7540 16670	*7940 17470	*7790 17170	5690 12570
	-4.6m -15'	Kg lb			*19840 43770	*19840 43770	*15090 33270	*15090 33270	*11640 25670	10740 23670	*8740 19270	7090 16970		*7640 16770	6990 15370
	-6.1m -20'	Kg lb					*10690 23570	*10690 23570	*7890 17370	*7890 17370				*6840 15070	*6840 15070

#### NOTES

- Lifting capacities shown do not exceed 75% of minimum tipping loads of 87% of hydraulic capacities. Capacities marked with an asterisk (\*) are limited by hydraulic capacities.
- Lifting capacities shown should not be exceeded. Weight of all lifting accessories must be considered part of the load.

- Lifting capacities assume the machine is standing level on a firm, uniform supporting surface. The user must make allowances for unfavorable job conditions such as soft or uneven ground or sudden stopping of loads.
- The least stable position is over the side.

- The operator should be fully acquainted with the Komatsu Operation Manual before operating the machine.
- Capacities apply only to the machine as originally manufactured and normally equipped by Komatsu.
- Ratings are based on SAE Standard No. J1097.



# PC400HD-5

Equipped with 750 mm (29.5") triple grouser shoes and a 1.82 m<sup>3</sup> (2.38 yd<sup>3</sup>), 1350 kg (2,977 lb) ESCO STDP bucket with wear shrouds and teeth.

## HYDRAULIC EXCAVATOR

### Lifting Capacity

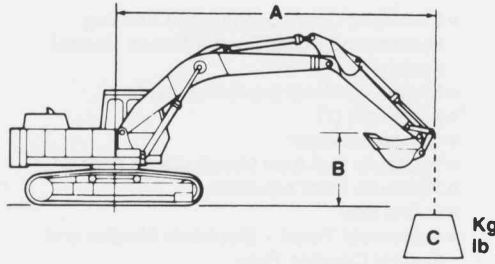

- A — Reach from swing centerline
- B — Bucket hook height
- C — Lifting capacities
- Rating over front
- Rating over side or 360 degrees
- Rating at maximum reach

A		1.5m/5'		3.0m/10'		4.6m/15'		6.1m/20'		7.6m/25'		9.1m/30'		10.7m/35'				
Arm	9.1m 30'	kg lb															*4640 10270	*4640 10270
	7.6m 25'	kg lb										*6540 14370	*6540 14370				*4440 9770	*4440 9770
	6.1m 20'	kg lb										*6740 14870	*6590 14570				*4390 9670	*4390 9670
	4.6m 15'	kg lb								*8090 17770	*8090 17770	*7190 15870	*6390 14070	*5990 13270	4740 10470		*4490 9970	*4470 9870
	3.0m 10'	kg lb				*15390 33870	*15390 33870	*11240 24770	*11240 24770	*9040 19970	*8390 18470	*7740 17070	6140 13570	*6840 15170	*4590 10170	*4740 10470	4190 9270	
	1.5m 5'	kg lb				*18190 40070	*17440 38470	*12690 27970	*11090 24540	*9990 21870	*7940 17570	*8290 18270	5890 12970	*7090 15670	4490 9870	*5140 11270	4090 9070	
	0.0m 0'	kg lb			*7440 16370	*7440 16370	*13790 30470	10640 23470	*10640 23470	*7590 16770	*5690 12570	*8640 19070	5690 12570	*7190 15870	4390 9670	*5740 12570	4140 9170	
	-1.5m -5'	kg lb	*7640 16870	*7640 16870	*11190 24670	*11190 24670	*19390 42770	16190 35670	*14090 31070	10340 22770	*10840 23970	7390 16270	*8690 19170	5540 12270			*6640 14570	4390 9770
	-3.0m -10'	kg lb	*11690 25870	*11690 25870	*15790 34870	*15790 34870	*18290 40370	16190 35770	*13640 30070	10240 22570	*10540 23170	7290 16070	*8140 18170	5540 12170			*7190 15870	4940 10870
	-4.6m -15'	kg lb	*16340 35970	*16340 35970	*21740 47870	*21740 47870	*16190 35670	*16190 35670	*12240 26970	10340 22870	*9390 20670	7390 16370					*7240 15970	5940 13070
	-6.1m -20'	kg lb			*16690 36770	*16690 36770	*12590 27770	*12590 27770	*9340 20570	*9340 20570							*6890 15170	*6890 15170
	-7.6m -25'	kg lb																
Arm	9.1m 30'	kg lb															*3490 7670	*3490 7670
	7.6m 25'	kg lb												*3390 7470	*3390 7470		*3340 7370	*3340 7370
	6.1m 20'	kg lb										*5940 13170	*5940 13170	*5540 12170	4890 10770	*3290 7270	*3290 7270	
	4.6m 15'	kg lb										*6490 14270	*6490 14270	*5990 13270	4790 10570	*3340 7370	*3340 7370	
	3.0m 10'	kg lb						*9990 22070	*9990 22070	*8240 18170	*8240 18170	*7090 15670	*6190 13670	*6340 13970	4640 10170	*3490 7770	*3490 7770	
	1.5m 5'	kg lb				*16590 36570	*16590 36570	*11790 26070	11440 25170	*9290 20470	8040 17670	*7740 17070	5890 13070	*6690 14770	4440 9770	*3740 8270	3490 7770	
	0m 0'	kg lb			*7940 17570	*7940 17570	*18640 41070	16740 36970	*13140 28970	10740 23670	*10140 22270	*7590 16770	*8240 18170	5640 12470	*6940 15270	4290 9470	*4140 9170	3540 7870
	-1.5m -5'	kg lb	*6390 14070	*6390 14070	*10290 22670	*10290 22670	*19290 42570	16140 35570	*13790 30470	10290 22670	*10590 23370	7290 16070	*8490 18770	5440 11970	*6990 15370	4190 9270	*4740 10470	3740 8270
	-3.0m -10'	kg lb	*9640 21270	*9640 21270	*13740 30270	*13740 30270	*8840 41570	15940 35170	*13740 30370	10090 22270	*10590 23370	7140 15770	*8390 18470	5340 11770	*6540 14470	4160 9170	*5690 12470	4090 9070
	-4.6m -15'	kg lb	*13390 29570	*13390 29570	*18240 40270	*18240 40270	*17340 38270	16040 35370	*12890 28470	10090 22270	*9890 21870	7140 15770	*7590 16770	5390 11870			*6490 14370	4790 10570
	-6.1m -20'	kg lb	*17940 39570	*17940 39570	*20440 45070	*20440 45070	*14640 32070	*14640 32270	*10990 24170	10290 22670	*8190 18070	7290 16170					*6390 14170	6140 13470
	-7.6m -25'	kg lb					*9040 21870	*9040 21870	*7090 15670	*7090 15670							*5740 12570	*5740 12570

### NOTES

1. Lifting capacities shown do not exceed 75% of minimum tipping loads of 87% of hydraulic capacities. Capacities marked with an asterisk (\*) are limited by hydraulic capacities.

2. Lifting capacities shown should not be exceeded. Weight of all lifting accessories must be considered part of the load.

3. Lifting capacities assume the machine is standing level on a firm, uniform supporting surface. The user must make allowances for unfavorable job conditions such as soft or uneven ground or sudden stopping of loads.

4. The least stable position is over the side.

5. The operator should be fully acquainted with the Komatsu Operation Manual before operating the machine.

6. Capacities apply only to the machine as originally manufactured and normally equipped by Komatsu.

7. Ratings are based on SAE Standard No. J1097.

## STANDARD EQUIPMENT

- All-weather sound suppression steel cab with tinted safety glass windows, pull-up type front window with lock device, removable lower windshield, lattice guard, lockable door, floor mat, intermittent window wiper and washer, adjustable suspension seat with armrest and seat belt, cigarette lighter, ashtray, heater and defroster, room light, glass protector brackets.
- Autodeceleration
- Automatic deaeration system for fuel line
- Automatic engine warm-up system
- Boom holding valve
- Double air cleaner element
- Dry-type air cleaner
- 8461 kg (18,654 lb) counterweight
- Electric horn
- Electronic Open-Center Load Sensing System and Pump Engine Mutual Control system
- Engine overheat prevention system
- Front light (1)
- Gauge protector
- Hydraulic lock type travel/parking brakes
- Hydraulic track adjusters
- In-line filter
- Instrument Panel – Electronic Monitor and Control Console Type: Caution lights, display lights, gauges, pilot indicators, and switches. Electrically controlled engine throttle dial. Service meter, electric
- Pins for boom foot and boom cylinder foot
- Power-max system
- Power mode selection system
- Proportional Pressure hydraulic control
- Radiator & oil cooler with dustproof screen
- Rearview mirror (RH)
- Service valve
- 750 mm (29.5") triple-grouser shoes
- Suction cooling fan
- Swing holding brake
- Track guiding guards (each side)
- 12 V/170 Ah x 2 batteries
- 25 A alternator
- 24 V/7.5 kW electric starting motor
- Two speed travel
- Variable track gauge
- Vandalism protection locks
- Working mode selection system
- Heater/Defroster
- Travel alarm

## ATTACHMENTS AND OPTIONAL EQUIPMENT

- Air conditioner
- Counterweight removal device
- Fuel supply pump
- Full roller guard
- Head guard
- Heavy duty boom and arm
- Rearview mirror (LH)
- 35A alternator
- Tool kit
- Track frame underguard
- Track roller guards (center)
- Warning lights for swing

### SHOES

	Triple grouser		Semi-double grouser
	700 (28)	750 (29.5)	750 (29.5)
Shoe width mm (in)	700 (28)	750 (29.5)	750 (29.5)
Machine ground pressure Kg/cm <sup>2</sup> (psi)	0.67 (9.53)	0.63 (8.96)	0.62 (8.82)
Additional weight kg (lb)	-91 (200)	0	-2621 (5,780)

### ARMS

Type	Length mm (ft.in)	Approx. Weight kg (lbs)
Extra Short	2388 (7'10")	1238 (2,730)
Short	2896 (9'6")	1288 (2,840)
Standard	3378 (11'1")	1275 (2,810)
Semi-long	3988 (13'1")	1594 (3,470)
Long	4800 (15'9")	1810 (3,990)

AESS358-00 4/91

Materials and specifications are subject to change without notice

**KOMATSU**  
KOMATSU MARKETING DIVISION

EQUIPEMENT FÉDÉRAL QUÉBEC LIMITÉE  
CASE POSTALE 1447, SUCC. ST-LAURENT  
ST-LAURENT, QC H4L 4Z1  
VENTES - PIÈCES - SERVICE  
(514) 341-4590 ou sans frais 1-800-361-1412

- JAN. 1992