

Manitowoc MLC650

Product Guide

ASME B30.5

Imperial

Preliminary



Features

- 716 USt capacity
- 28,114 ft-kips maximum load moment
- 65,473 ft-kips maximum load moment with VPC-MAX
- 341 ft No. 680 boom
- 98 ft No. 148 fixed jib on No. 680 boom
- 331 ft No. 681-682 luffing jib on No. 680 boom

Variable Position Counterweight

- > The Variable Position Counterweight (VPC) is proprietary technology available exclusively on Manitowoc crawler cranes. By allowing the crane's counterweight to be positioned automatically, the VPC provides an unmatched level of versatility and lifting capability.

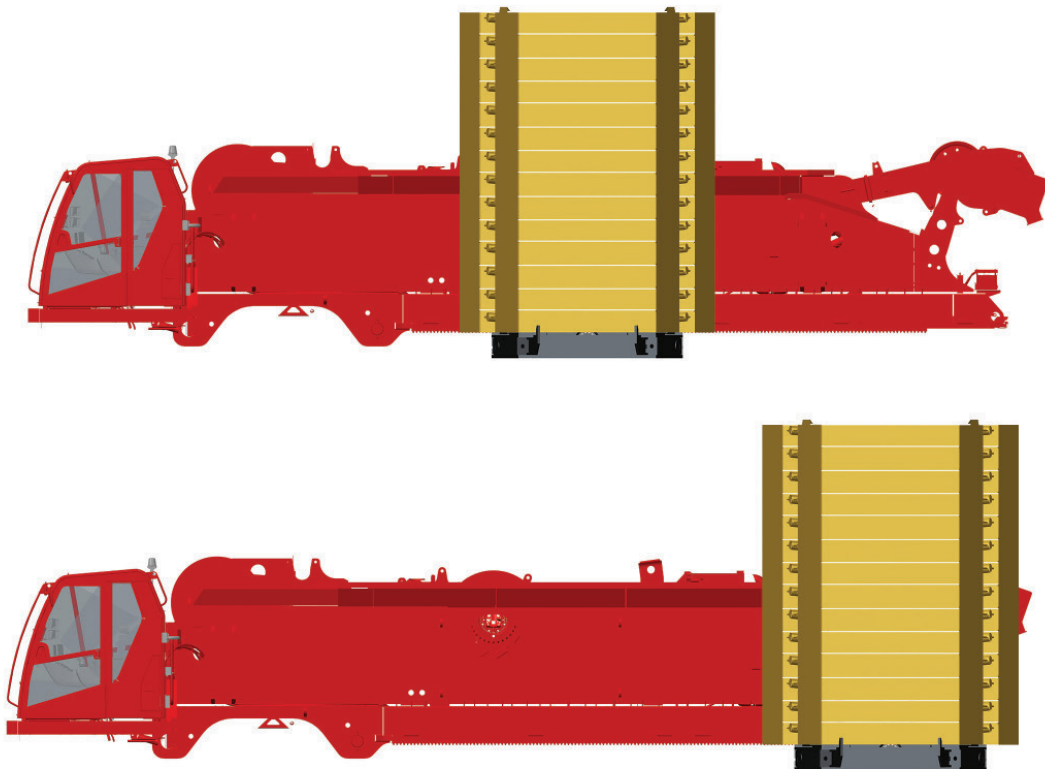

Jobsite benefits

Reduced ground bearing pressure

Moving counterweight allows counterweight to be positioned to better distribute ground bearing pressure during setup and lifting operations.

Less counterweight without sacrificing capacity

The VPC technology allows the upperworks counterweight to move based on stability requirements, eliminating the need for carbody counterweights. The weight typically added to the carbody can now be added to the upperworks to increase capacity while retaining performance and on-site mobility.

VPC-MAX (option)

Unlike VPC counterweight movement which is dictated by changes in boom angle, VPC-MAX counterweight movement is dictated by load and radius (forward moment) changes. As forward moment is increased or decreased VPC-MAX counterweight position is changed to offset changes in moment.

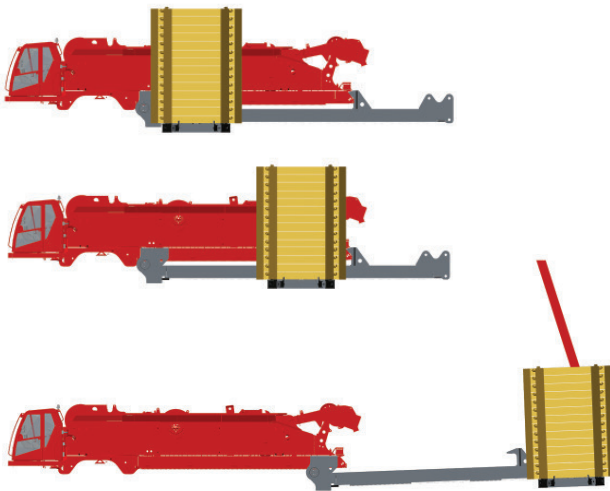

In VPC-MAX configuration, the counterweight tray moves to the end of the VPC-MAX beam prior to beam extension, thus minimizing tailswing and increasing job site mobility.

Counterweight is automatically positioned to optimize rearward moment as forward moment is increased or decreased.

Minimal ground preparation

In VPC-MAX configuration the counterweight assembly never touches the ground, allowing for minimal ground preparation. The MLC650 ground preparation area is approximately one-tenth of that required by the leading competition, saving time and cost during job site preparation.

Ground prep area comparison

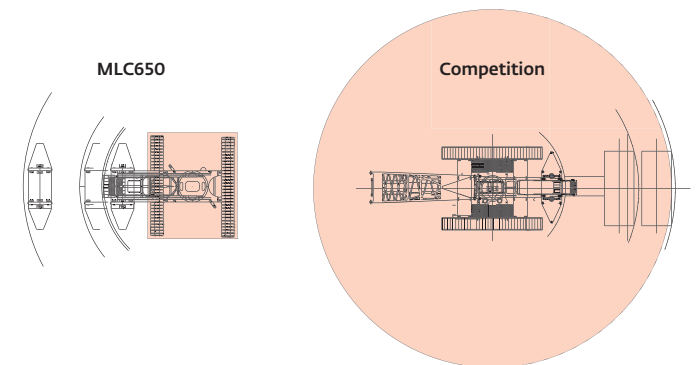

Water applications

Counterweight never touches ground allowing use in barge applications where wheeled or hanging attachments that contact the operating surface are typically not allowed. Moving counterweight also better maintains center of gravity for reduced ground bearing pressures.

Features



Crane Control System

The Crane Control System offers a user-friendly interface, two full graphic displays mounted horizontally for better visibility, a jog dial for easier data input and ergonomic joysticks.

Variable Position Counterweight (VPC)

The Manitowoc MLC650 features a counterweight system which automatically positions the crane's counterweight as required to match lifting demands. Crane lifting capability is optimized by automatic positioning of the counterweight; eliminating the need for carbody counterweight. Additionally, counterweight boxes are designed to be common across multiple crane platforms and will be utilized on Manitowoc Model MLC300 as well as future new models.

VPC-MAX

Capacity and boom and jib combination lengths can be increased through addition of the exclusive VPC-MAX attachment. The VPC-MAX attachment, utilizing all of the standard VPC components, increases the max load moment of the MLC650 when a 118' 1" fixed mast, VPC-MAX counterweight beam and additional 220,460 lb of counterweight is added to the base MLC650. The position of the VPC-MAX counterweight is automatically positioned based on lifted load, boom length or boom and jib length and load radius.

Transport

The MLC650 is designed to be transported globally with optimized component weights and dimensions. The MLC650 features a removable live mast shipping module and boom inserts designed to allow luffing jib inserts to ship within the boom inserts for cost effective transport.

FACT™ Connectors

Manitowoc's Fast Aligning Connection Technology (FACT) automatically aligns crane components for fast, easy assembly.

Contents

Specifications	6
Outline dimensions	9
Transport data	17
Assembly	18
Performance data	20
Boom combinations	22
Main boom range / load charts	25
Extended UBP range / load charts	27
Luffing jib range / load charts	29
VPC-MAX complete information	33
Manitowoc Crane Care	43

Specifications

Upperworks



Engine

Cummins Model QSX15 Tier 4 Final diesel, 600 BHP at 1800 RPM.

Or

Cummins QSX15 Tier 3 diesel, rated 600 HP at 1800 RPM

Includes pump drive disconnect for easier starting, engine block heater (240V), high silencing muffler or emissions compliant Tier 4 Final after treatment, hydraulic oil cooler, radiator and variable speed hydraulic controlled fan. Variable speed fan provides increased fuel efficiency, decreased engine loading and reduces noise emission.

Multiple hydraulic pump drive transmission provides power for all machine functions. Two 12 volt, 1375 CCA at 0° F, 24 volt system and 110 amp alternator. 295 gallon fuel tank, with level indicator in operator's cab.

- Optional: Cold-weather package with heater for fluids.



Crane Control System

The Crane Control System offers a user-friendly interface, two full graphic displays mounted horizontally for better visibility, a jog dial for easier data input and ergonomic joysticks.



Hydraulic system

High-pressure piston pumps, driven by a multi-pump transmission, provide independent closed-loop hydraulic power for the hoisting drums, boom hoist, swing, left crawler and right crawler.

250 gallon hydraulic reservoir is equipped with breather, clean out access, and internal diffuser.

Each function is equipped with relief valves to protect the hydraulic circuit from overload or shock.

System includes oil cooler and replaceable, full flow return filters. All oil is filtered before entering the hydraulic reservoir.



Drums

Basic machine is equipped with 49" wide and 26" diameter main hoist drum, mounted in the boom butt and 32" wide and 25.25" diameter whip drum, mounted in the rotating bed. Each drum is driven by a variable-displacement hydraulic motor through a planetary reduction system. Main hoist drum is grooved for 32mm rope and whip drum is grooved for 28 mm rope.

Powered hoisting/lowering operation is standard with automatic (spring applied, hydraulically released) multi-disc brakes, and drum rotation indicators

- Optional: auxiliary main hoist with 49" wide and 26" diameter mounted in the 13' 1" insert. Aux main hoist drum is grooved for 32mm rope.



Moving mast system

Independent moving mast hoist with two grooved drums, each 18.5" wide and 31" diameter drum grooved for 32 mm diameter wire rope.

Drum is powered by variable-displacement hydraulic motors coupled to integral brake and planetary reduction gearboxes. Ratcheting pawl and rotation indicator are standard.

Raise 341' full main boom from 0° - 85° in 7 minutes 40 seconds.



Swing system

High strength steel adapter module is mounted on 118" diameter triple row roller turntable bearing. Bearing adapter-mounted independent swing is powered by two fixed-displacement hydraulic motors coupled to internal brakes and planetary reductions.

Swing system maximum speed: 1.3 rpm liftcrane, 0.9 rpm VPC-MAX.

Specifications



Boom support system

Moving mast is 36' long and connects the boom hoist reeving to the steel boom suspension strap rigging. When used with the optional self-erect package, the mast is used for crane assembly and disassembly. It is capable of lifting and positioning the crawler assemblies, and assembling the boom and luffing jib.

Spring cushioned boom stop and automatic boom stop are standard.



Variable Position Counterweight

The Variable Position Counterweight (VPC) system of rotating bed only counterweight maintains optimum crane stability by automatically positioning crane counterweight based on boom angle and length. No carbody counterweight is required.

The crane is equipped with 661,386 lbs upperworks only counterweight made up of a single piece counterweight tray and twenty-eight 22,046 lbs counterweight boxes. Left and right side counterweights are interchangeable and common with MLC300 counterweight.



Vision operator's cab

The Vision Cab™ is a fully enclosed and insulated galvanized steel fabricated module mounted to the left front corner of rotating bed. Operator's cab is equipped with power tilt, sliding door, large safety glass windows, front and roof windshield wipers, dome light, sun visor and shade, fire extinguisher, air conditioning, swing and travel alarms, and radio/CD player. Operator's station swings over front of rotating bed for transportation.

- Optional: Polyethylene protective window covers.

Lowerworks



Carbody and adapter assembly

Connects rotating bed and crawler frames. Each frame is mounted to the carbody with FACT connection system and hydraulic power-actuated pins. Crawler drive motors are mounted on carbody, permitting crawler removal without opening travel drive hydraulic circuit.



Crawlers

Crawler assemblies are 36'5" long with 60" wide cast steel crawler pads and automatically lubricated intermediate rollers. Left and right side crawlers are interchangeable to provide assembly/disassembly flexibility on job sites. Carbody mounted drive motors are connected to crawler final reduction via drive shafts. Crawlers provide ample tractive effort for travel and counter-rotating with full rated load.

Maximum ground speed of 0.78 mph.

- Optional: 80" wide cast steel crawler pads

Attachments



No. 680 boom

The liftcrane is equipped with 105' 680 basic boom consisting of 19' 8" butt, 13' 1" insert, 39' 5" insert with luffing hoist sheaves, and 32' 10" top with sixteen 30" diameter tapered roller bearing sheaves. Includes rope guides, boom hoist wire rope, boom angle indicator and hook and weight ball. The boom utilizes Manitowoc's exclusive FACT™ connection system boom connector. Spring cushioned boom stop. Automatic boom stop.

- Optional: 19' 8" and 39' 5" No. 680 boom inserts with steel boom suspension straps and FACT connection system.
- Optional: detachable upper boom point with one 30" diameter tapered roller bearing steel sheave grooved for 32 mm rope with rope guard for liftcrane.
- Optional: Heavy-duty 146.4 USSt detachable extended upper boom point with three 30" diameter tapered roller bearing steel sheave grooved for 32mm rope with rope guard for liftcrane.

Specifications



No. 681-682 luffing jib

85' basic No. 681-682 luffing jib including 19' 8" butt, one 39' 5" insert, 19' 8" transition insert and 6' 7" top, main and jib struts, jib and backstay steel suspension straps, boom point guide wheel, luffing jib hoist with ratchet and pawl; quick disconnect for jib hoist piping, and 28 mm luffing jib hoist line.

- Optional: 9' 10", 19' 8" and 39' 5" No. 681 and 682 luffing jib inserts with steel boom suspension straps.

Utilize luffing jib inserts in combination with the No. 681-682 basic luffing jib for total luffing jib lengths up to 331'.



No. 148 fixed jib

39'4" No. 148 fixed jib including pin 19'8" butt, 19'8" top, jib strut and mounting hardware.

- Optional: 19'8" No. 148 inserts with pin connectors and pendants for a maximum jib length of 98' 5".



VPC-MAX

The VPC-MAX attachment components include:

- 118' 1" of No. 684 mast consisting of a 19' 8" butt, (2) 39' 4" inserts, and a 19' 8" top.
- One additional swing drive (for a total of three) mounted on the rotating module. Each swing drive is powered by a fixed-displacement hydraulic motor coupled to a planetary reduction gearbox and internal brake.
- Counterweight includes an additional ten 22,046 lb boxes.

The VPC-MAX system maintains optimum crane stability by automatically positioning crane counterweight behind the crane's centerline of rotation based on lifted load, boom length and load radius.

Optional equipment

- Self-erect system includes, jacking cylinders with pads, self assembly cylinder and crawler handling chains.
- Hydraulic Test Kit: required to properly analyze the performance of the CCS.
- Service Interval Kits for the regularly scheduled maintenance of general crane operations.
- Special paint color(s) other than Manitowoc standard red and black.
- Custom vinyl decal(s) of customer name and/or logo from artwork supplied by customer.
- 20 USt swivel hook and weight ball.

Outline dimensions

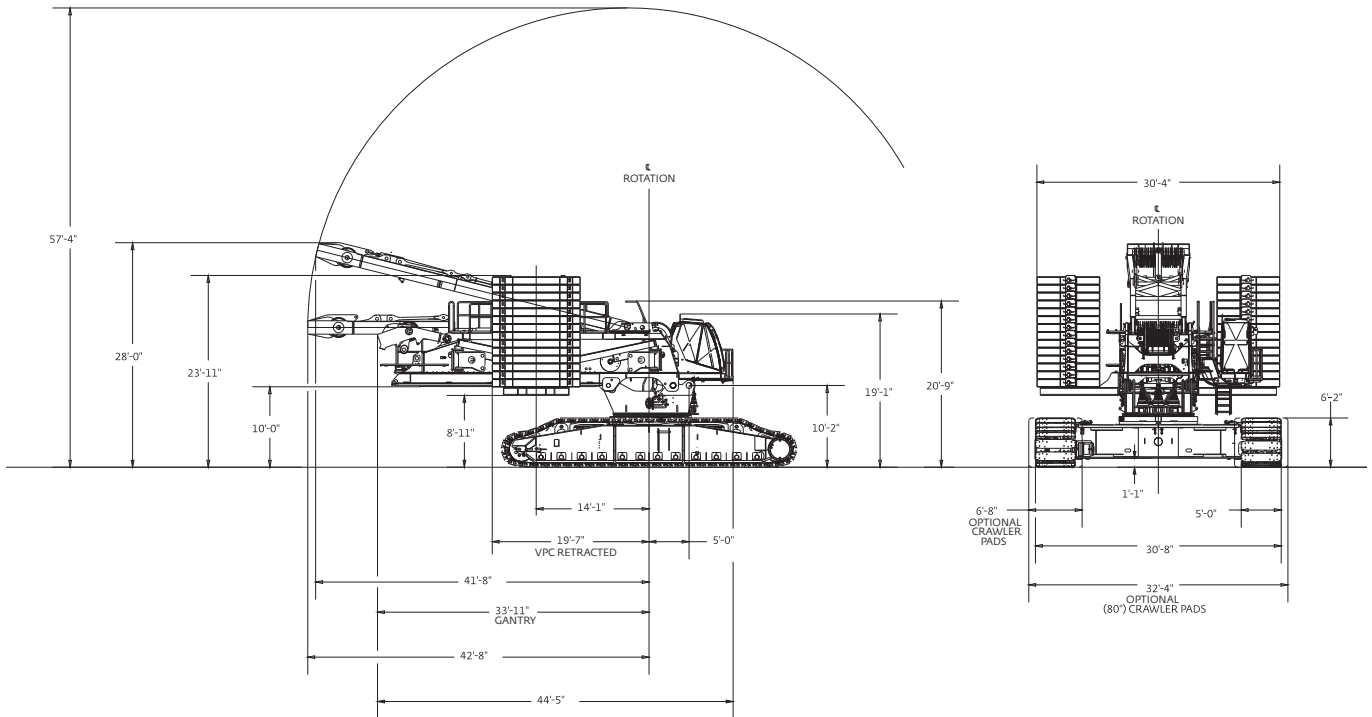
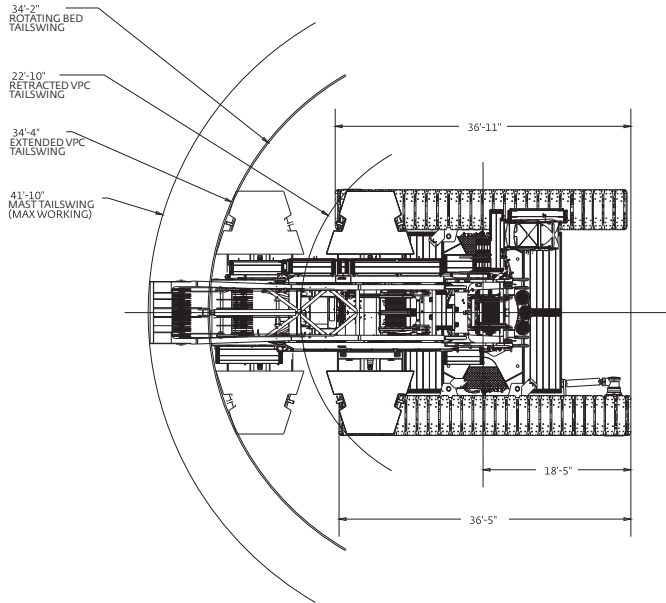

Outline dimensions

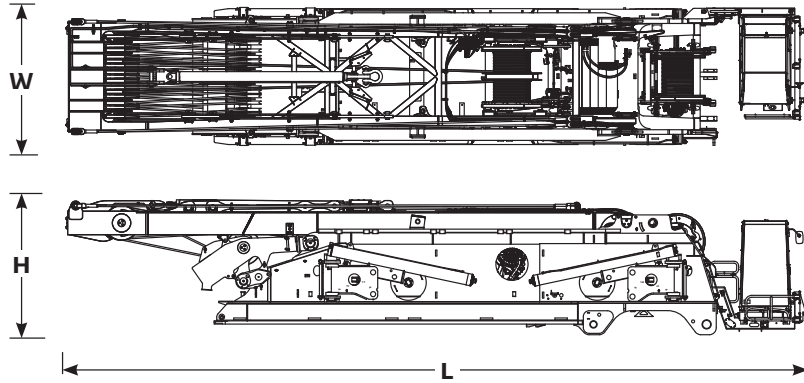

Rotating bed assembly

Length	52' 9"
Width	9' 10"
Height	9' 8"
Weight	157,850 lb

Note: includes live mast, boom hoist, gantry, rotating bed jacks, whip hoist.

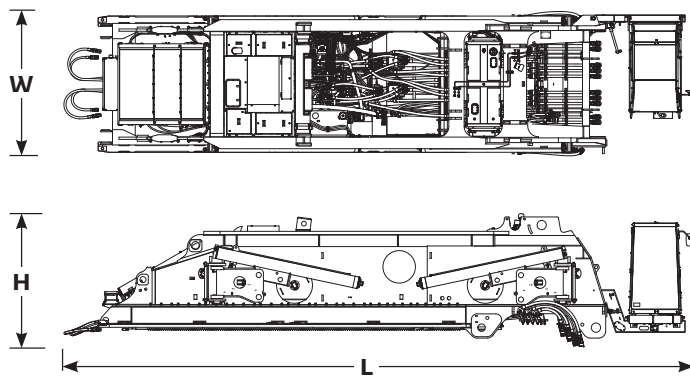

Rotating bed assembly

Length	42' 3"
Width	9' 10"
Height	8' 7"
Weight	98,450 lb

*Note: includes rotating bed jacks, whip hoist.
Note: excludes live mast, boom hoist, gantry.*

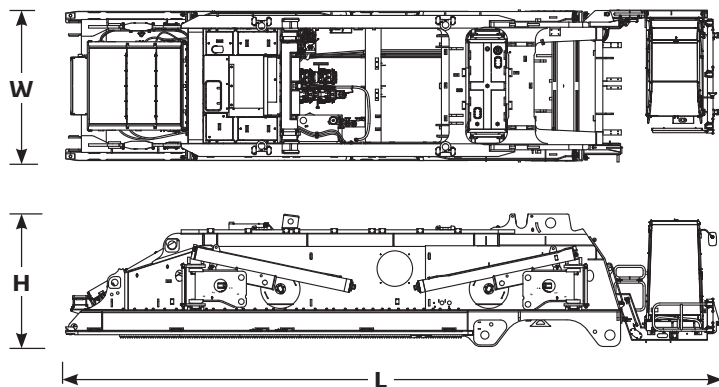

Rotating bed assembly

Length	42' 3"
Width	9' 10"
Height	8' 7"
Weight	85,950 lb

*Note: includes rotating bed jacks.
Note: excludes whip hoist, live mast, boom hoist, gantry.*

Outline dimensions

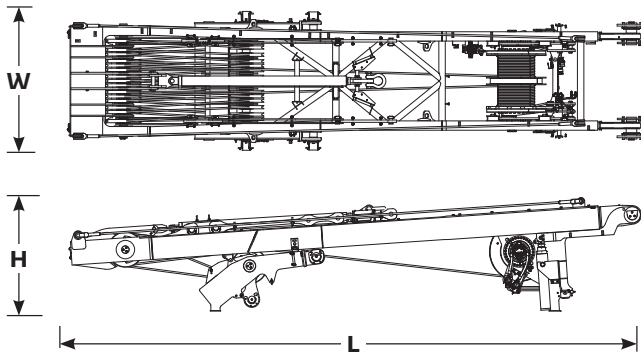

Live mast package

Length	40' 7"
Width	9' 10"
Height	8' 1"
Weight	59,400 lb

Note: includes live mast, boom hoist, gantry.

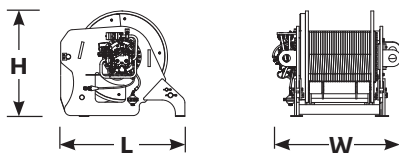

Whip hoist package

Length	5' 4"
Width	5' 4"
Height	4' 7"
Weight	12,500 lb

Note: includes wire rope.

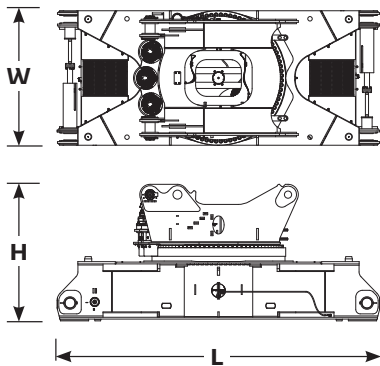

Carbody assembly without jacks

Length	23' 7"
Width	9' 10"
Height	10' 0"
Weight	92,300 lb

Note: includes carbody, adapter frame, three swing drives, slewing ring.

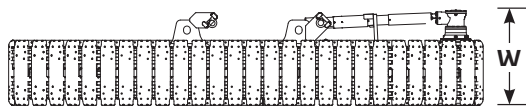

Crawler assembly 60" pads

Length	36' 6"
Width	7' 5"
Height	6' 2"
Weight	86,000 lb

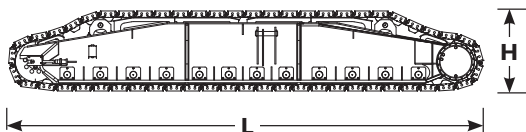

Crawler assembly 80" pads

Weight	104,760 lb
--------	------------

Outline dimensions

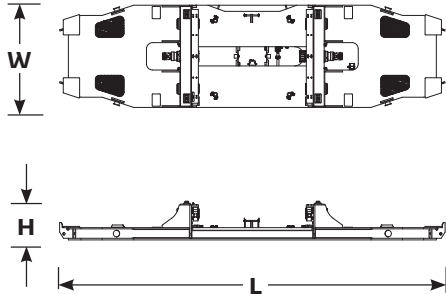

Counterweight tray assembly

Length	30' 11"
Width	8' 2"
Height	3' 1"
Weight	44,000 lb

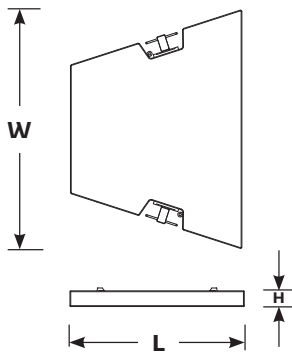

Counterweight box

Length	7' 10"
Width	10' 11"
Height	1' 2"
Weight	22,046 lb

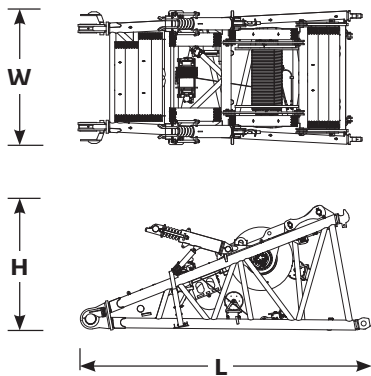

19' 8" No. 680 boom butt

Length	21' 4"
Width	9' 10"
Height	9' 2"
Weight	43,150 lb

Note: main load hoist #1, wire rope, rigging winch.

19' 8" No. 680 boom butt with luffing hoist

Weight	53,750 lb
--------	-----------

Note: includes main load hoist #1, wire rope, rigging winch, luffing hoist.

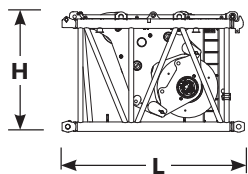

13' 1" No. 680 boom insert

Length	14' 0"
Width	9' 10"
Height	9' 2"
Weight	39,460 lb

Note: main load hoist #2, wire rope.

Outline dimensions

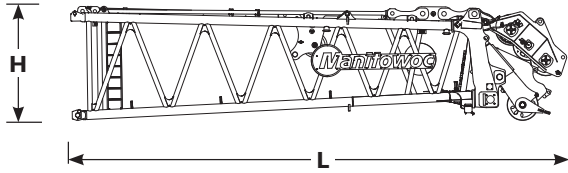

32' 10" No. 680 boom top

Length	40' 0"
Width	9' 10"
Height	9' 2"
Weight	41,550 lb

Note: lower boom point, wire rope guides.

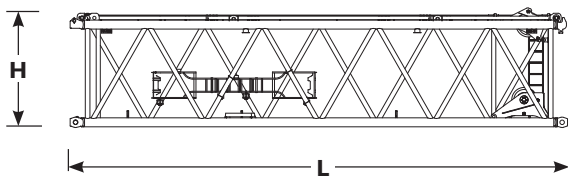

39' 4" No. 680 boom insert with sheaves

Length	40' 3"
Width	9' 10"
Height	9' 2"
Weight	27,150 lb

Note: boom straps, backstay straps, luffing jib wire rope guide.

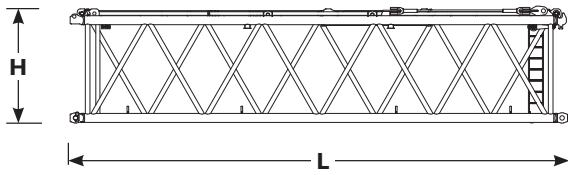

39' 4" No. 680 boom insert, heavy with equalizer

Length	40' 3"
Width	9' 10"
Height	9' 2"
Weight	23,140 lb

Note: boom straps, backstay straps.

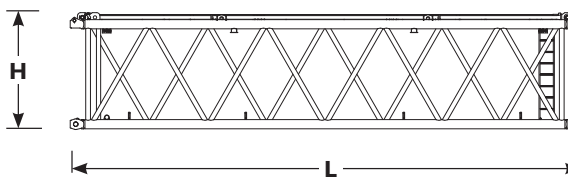

39' 4" No. 680 boom insert, heavy

Length	40' 3"
Width	9' 10"
Height	9' 2"
Weight	21,460 lb

Note: boom straps, backstay straps.

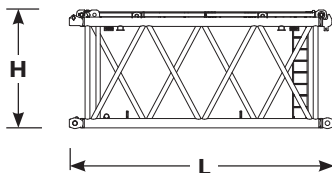

19' 8" No. 680 boom insert, heavy

Length	20' 7"
Width	9' 10"
Height	9' 2"
Weight	12,520 lb

Note: boom straps, backstay straps.

Outline dimensions

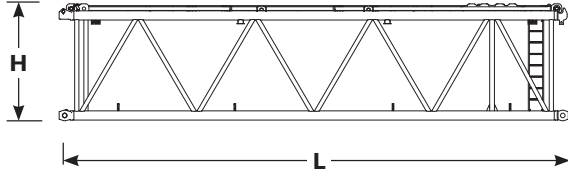

39' 4" No. 680 boom insert, medium with suspension

Length	40' 3"
Width	9' 10"
Height	9' 2"
Weight	22,740 lb

Note: boom straps, backstay straps.

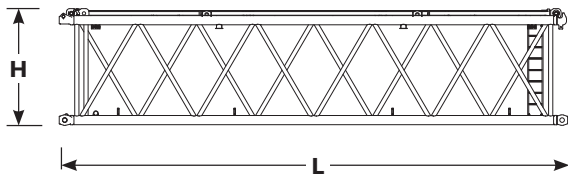

39' 4" No. 680 boom insert, medium

Length	40' 3"
Width	9' 10"
Height	9' 2"
Weight	17,560 lb

Note: boom straps, backstay straps.

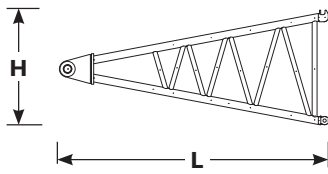

19' 8" No. 681 luffing jib butt

Length	21' 0"
Width	9' 10"
Height	8' 11"
Weight	16,262 lb

Note: includes jib stops.

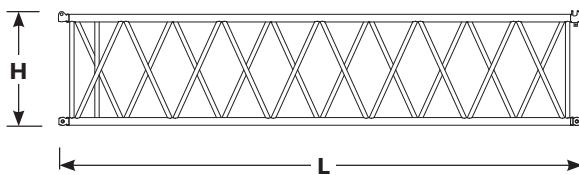

39' 4" No. 681 luffing jib insert

Length	40' 3"
Width	9' 10"
Height	9' 3"
Weight	13,485 lb

Note: includes jib straps.

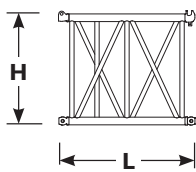

9' 10" No. 681 luffing jib insert

Length	10' 5"
Width	9' 10"
Height	9' 3"
Weight	4,955 lb

Note: includes jib straps.

Outline dimensions

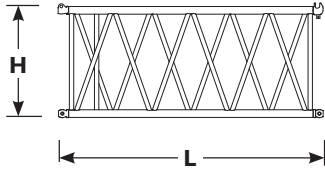

19' 8" No. 681 luffing jib insert

Length	20' 3"
Width	9' 10"
Height	9' 3"
Weight	8,080 lb

Note: includes jib straps.

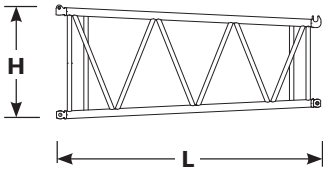

19' 8" No. 681-682 transition insert

Length	20' 3"
Width	9' 10"
Height	9' 3"
Weight	7,900 lb

Note: includes jib straps.

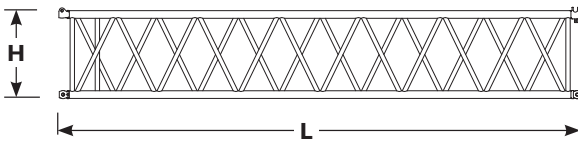

39' 4" No. 682 luffing jib insert

Length	40' 0"
Width	8' 2"
Height (max)	7' 6"
Weight	13,155 lb

Note: includes jib straps.

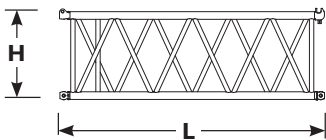

19' 8" No. 682 luffing jib insert

Length	20' 3"
Width	8' 2"
Height	7' 6"
Weight	7,520 lb

Note: includes jib straps.

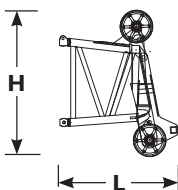

6' 6" No. 681-682 luffing jib top

Length	10' 11"
Width	8' 2"
Height (max)	9' 3"
Weight	12,620 lb

Note: includes (8) sheave pack, wire rope guide.

Outline dimensions

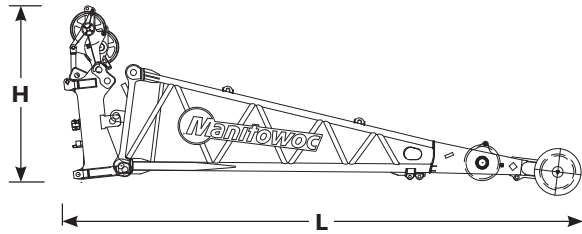

Wind cap + extended upper boom point

Length	37' 9"
Width	8' 10"
Height (max)	9' 3"
Weight	20,538 lb

Note: includes 2 sheave lower boom point in wind cap.

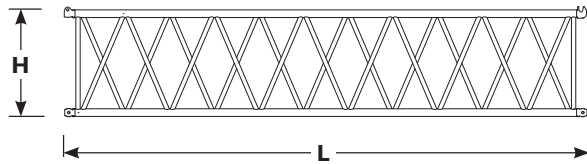

39' 4" No. 684 mast insert

Length	40' 5"
Width	8' 2"
Height (max)	9' 3"
Weight	15,230 lb

Note: includes backhitch and counterweight straps.

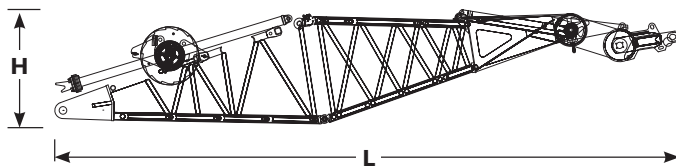

No. 684 mast top + butt transport package

Length	47' 10"
Width	8' 7"
Height	9' 3"
Weight	56,703 lb

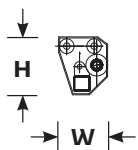

VPC-MAX actuator assembly

Length	16' 5"
Width	3' 10"
Height	3' 10"
Weight	10,000 lb

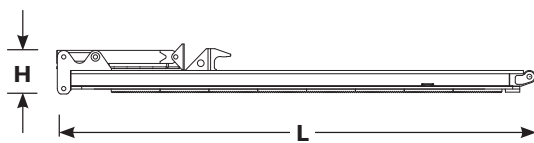

VPC-MAX beam assembly

Length	36' 8"
Width	9' 10"
Height	3' 10"
Weight	47,000 lb

Transport data

Load summary																															
Item	Qty	Weight lb	282 ft boom																												
			Quantity on trailer load #																												
			(Does not include blocking, strapping, etc.)																												
			1	2	3	4	5	6	7	8	9	10	11	12	13	14	15	16	17	18	19	20	21	22	23	24	25	26	27	28	29
Upperworks module	1	85,950	1																												
Whip hoist	1	12,500									1																				
Live mast package	1	59,400		1																											
Carbody + adapter	1	92,300			1																										
Crawler assembly (60" pads)	2	86,000				1	1																								
Counterweight tray	1	44,000						1																							
Counterweight box	28	22,046																2	2	2	2	2	2	2	2	2	2	2	2	2	
Boom butt with drum 1	1	43,150							1																						
13' 1" No. 680 boom insert with drum 2	1	39,460								1																					
39' 4" No. 680 heavy boom insert	1	27,150									1																				
39' 4" No. 680 heavy boom insert	1	21,460										1																			
39' 4" No. 680 heavy boom insert with equalizer rails	1	23,140											1																		
19' 8" heavy boom insert	1	12,520												1																	
39' 4" medium insert with suspension	1	22,740													1																
39' 4" medium insert	1	17,560														1															
32' 10" boom top	1	41,550															1														
350 t block (32 mm)	1	17,400												1																	
22,2 mt weight ball	1	2,800										1																			
Approximate total shipping weight lb			85,950	59,400	92,300	86,000	86,000	44,000	43,150	39,460	39,650	24,260	23,140	29,920	22,740	17,560	41,550	44,092	44,092	44,092	44,092	44,092	44,092	44,092	44,092	44,092	44,092	44,092	44,092	44,092	

Assembly

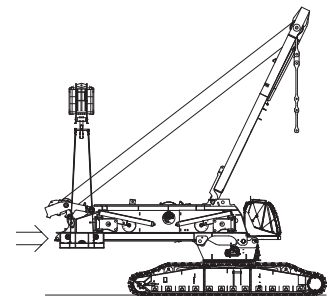
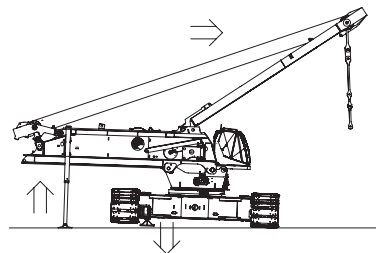
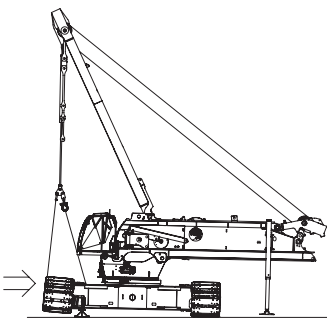
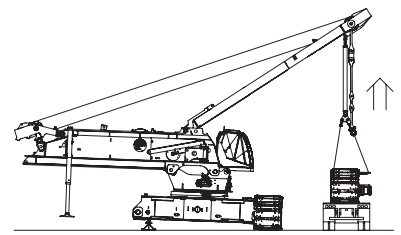
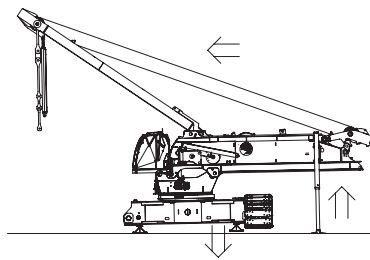
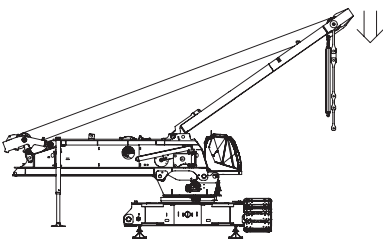
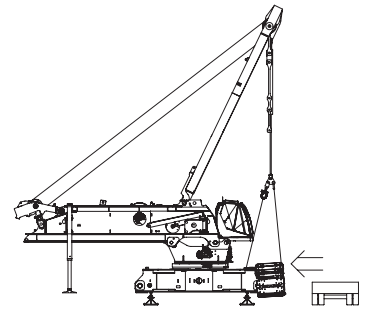
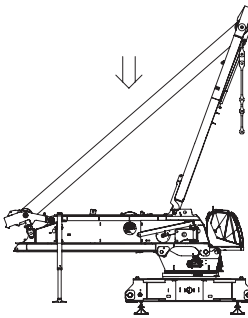
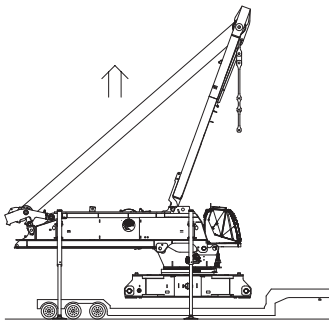
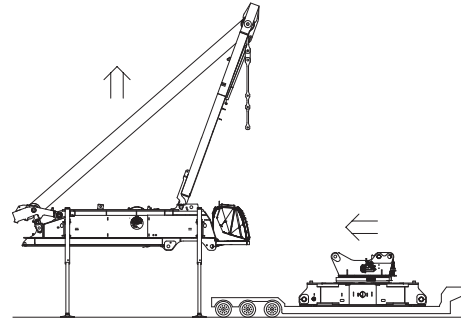
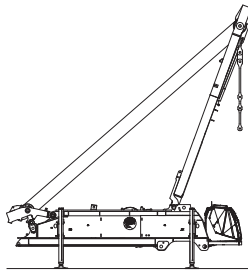
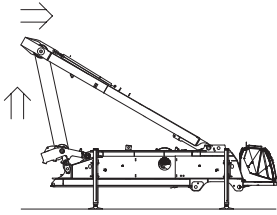
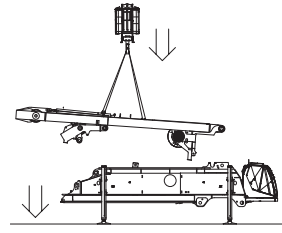
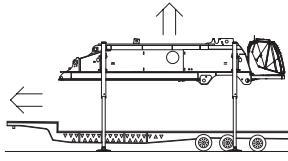
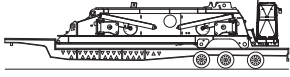

Assembly

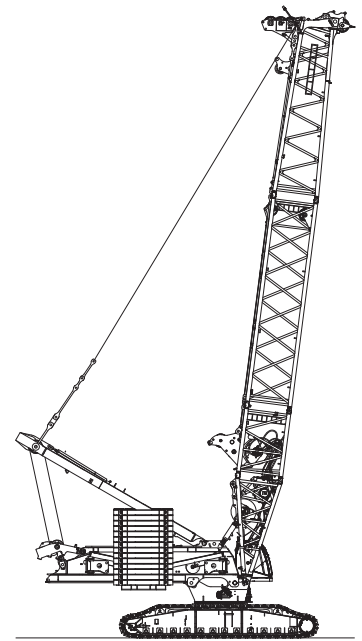
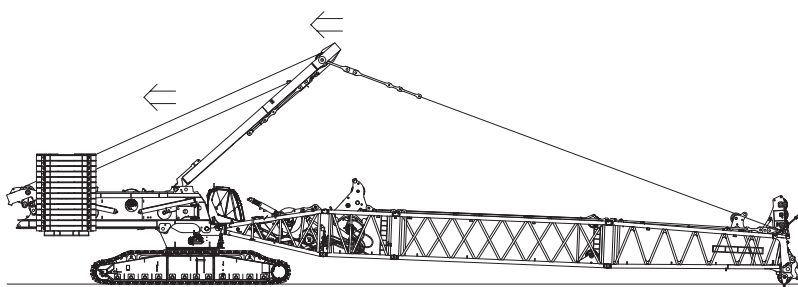
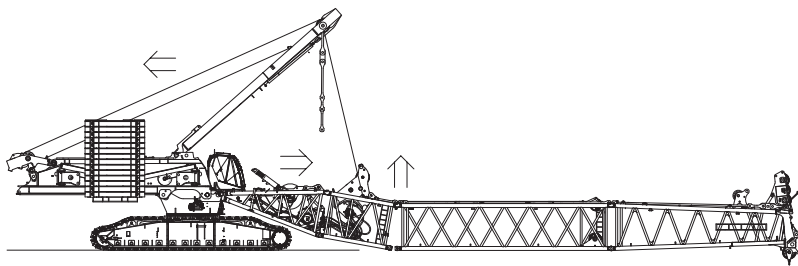
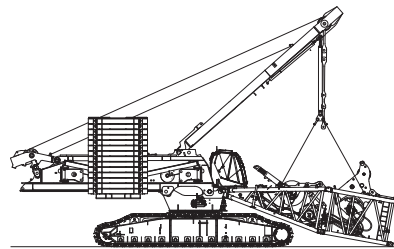
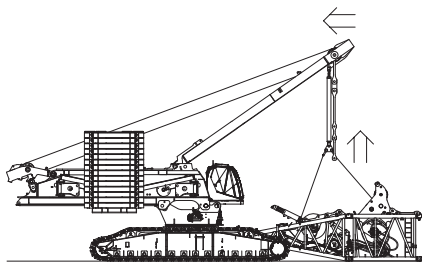
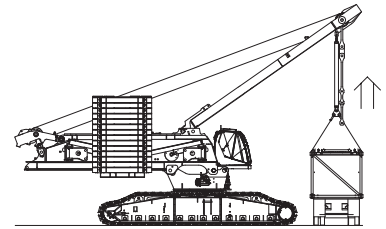
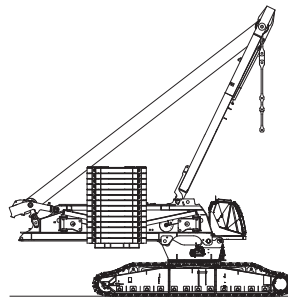
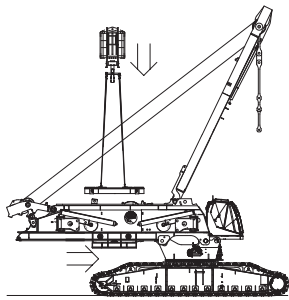

Performance data

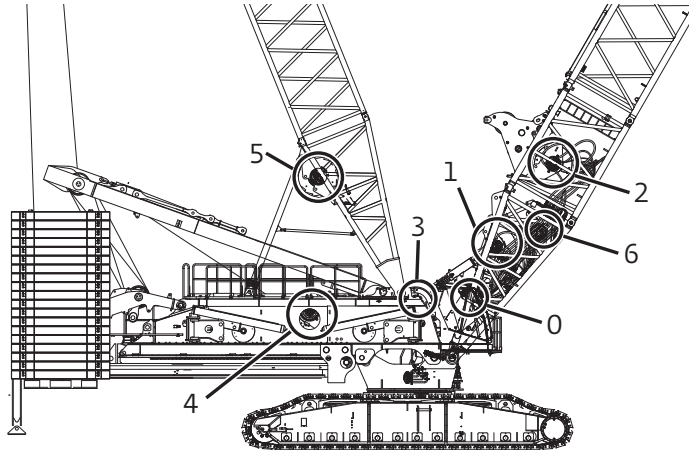

Drum identification	
Drum number	Function
1	Main hoist - standard
2	Auxiliary main hoist - optional
3	Whip hoist - standard
4	Boom hoist (VPC) - standard Mast hoist (VPC-MAX) - standard
5	Boom hoist (VPC-MAX) - optional
6	Luffing hoist - optional
0	Rigging winch - optional

Working weight	
	lb
105' No. 680 main boom, upper boom point, 600 ton hook block 661,390 lb counterweight	1,243,700

Performance data

No. 680 boom Hoist reeving for main load block single lead line - 32 mm wire rope	
No. Parts of Line	Maximum Load lb
2	97,600
4	195,200
6	292,800
8	390,400
10	488,000
12	585,600
14	683,200
16	773,610
18	861,860
20	948,350
22	1,033,110
24	1,116,200
26	1,197,620
28	1,277,430
30	1,355,650
32	1,432,310

No. 680 boom Hoist reeving for main load block two lead lines - 32 mm wire rope	
No. Parts of Line	Maximum Load lb
8	390,400
12	585,600
16	780,800
20	976,000
24	1,171,200
28	1,366,400
32	1,543,230

No. 680-681 boom with 25 ft extended upper boom point Hoist reeving for main load block single lead line - 32 mm wire rope	
No. Parts of Line	Maximum Load lb
2	97,600
4	195,200
6	292,800

No. 680 boom Hoist reeving for whip load block single lead line - 28 mm wire rope	
No. Parts of Line	Maximum Load lb
1	30,000
2	60,000

Maximum spooling capacities	
Drum 1 (hoist line) 32 mm wire rope*	3,609 ft 10 layers
Drum 2 (hoist line) 32 mm wire rope*	3,609 ft 10 layers
Drum 3 (whip line) 28 mm wire rope*	1,900 ft 8 layers

*21 ft is deducted from maximum spooling capacities for 3 dead wraps per drum

Performance for main hoist (drum #1) and auxiliary main hoist (drum #2) 32 mm wire rope Single line speed in ft per minute										
Single line pull lb	Single line pull/single line speed ft/min Layer									
	1	2	3	4	5	6	7	8	9	10
0	307	335	364	392	421	449	477	506	534	563
10,000	293	319	344	369	394	419	443	467	491	515
20,000	279	302	324	346	368	389	409	429	439	445
30,000	265	285	294	300	305	311	316	321	327	332
40,000	227	233	238	244	249	254	260	265	274	288
48,800	197	202	208	213	218	230	244	254	253	252

Performance for whip (drum #3) 28 mm wire rope Single line speed in ft per minute								
Single line pull lb	Single line pull/single line speed ft/min Layer							
	1	2	3	4	5	6	7	8
0	297	322	347	371	396	421	446	471
5,000	284	306	329	351	373	394	416	437
10,000	270	291	311	330	349	368	386	404
15,000	257	275	291	296	301	305	310	315
20,000	225	230	235	240	244	249	254	258
25,000	192	196	201	206	211	216	228	240
30,000	169	174	179	190	202	214	225	237

Boom combinations

No. 680 main boom combinations					
Boom length ft	Main boom inserts ft				
	13.1 XH	19.7 H	39.4 XH	39.4 H	39.4 M
105	1	0	1	0	0
124.7	1	1	1	0	0
144.4	1	0	1	1	0
164	1	1	1	1	0
183.7	1	0	2	1	0
203.4	1	1	2	1	0
223.1	1	0	2	1	1
242.8	1	1	2	1	1
262.5	1	0	2	2	1
282.2	1	1	2	2	1
301.8	1	0	2	3	1
321.5	1	1	2	3	1
341.2	1	0	2	4	1

XH: Extra heavy insert

H: Heavy insert

M: Medium insert

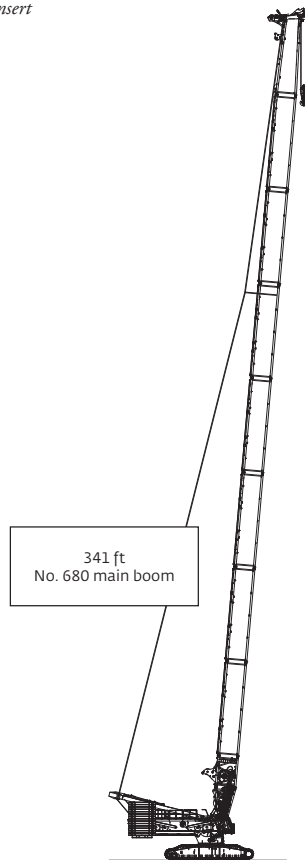

Boom combinations

No. 680-681 WA boom with 24.9 ft extended upper boom point								
Boom length ft	Main boom inserts ft							
	13.1 XH	39.4 XH	39.4 H	39.4 M	9.8*	19.7*	19.7**	39.4*
292	1	2	2	1	0	0	1	1
301.8	1	2	2	1	1	0	1	1
311.7	1	2	2	1	0	1	1	1
321.5	1	2	2	1	1	1	1	1
331.4	1	2	2	1	0	0	1	2
341.2	1	2	2	1	1	0	1	2
351	1	2	2	1	0	1	1	2
360.9	1	2	2	1	1	1	1	2

XH: Extra heavy insert
H: Heavy insert
M: Medium insert
** luffing jib insert*
*** luffing jib transition insert*

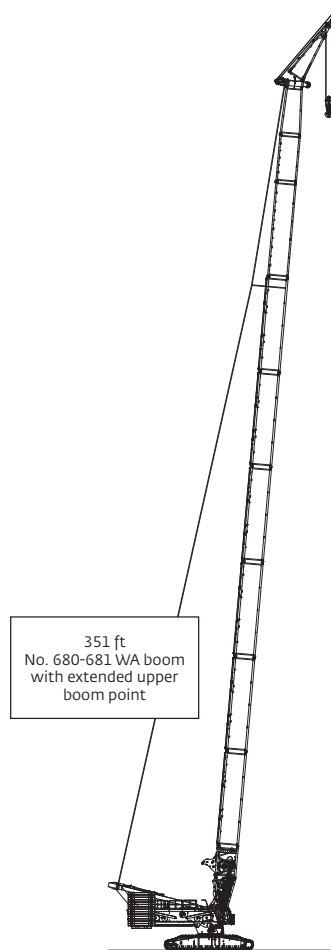

Boom combinations

No. 681-682 luffing jib combinations					
Luffing jib length ft	Luffing jib inserts ft				
	9.8	19.7	19.7*	39.4	39.4*
85.3	0	0	0	1	0
95.1	1	0	0	1	0
114.8	1	1	0	1	0
134.5	1	0	0	2	0
154.2	1	1	0	2	0
173.9	1	1	1	2	0
193.6	1	1	0	2	1
213.3	1	1	1	2	1
232.9	1	1	0	2	2
252.6	1	1	1	2	2
272.3	1	1	0	2	3
292	1	1	1	2	3
311.7	1	1	0	2	4
331.4	1	1	1	2	4

* Shallow depth inserts

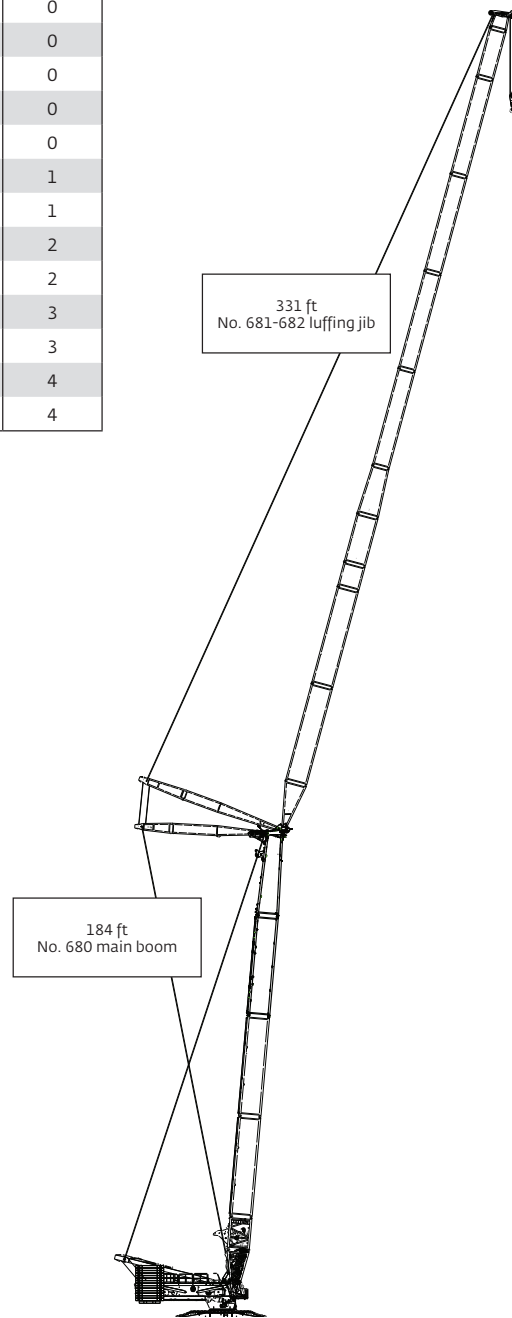

Main boom range diagram

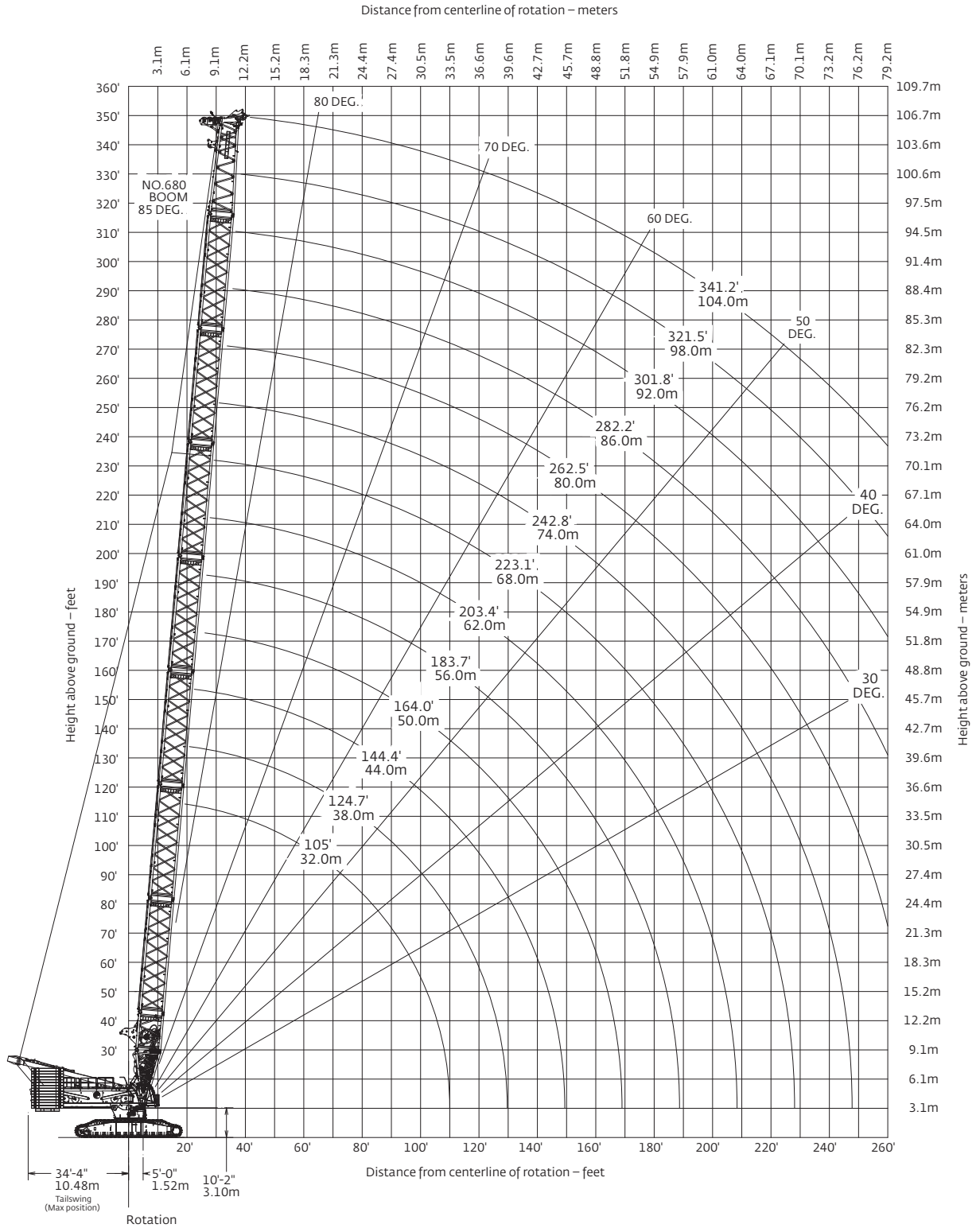

Main boom load charts

No. 680 boom													
661,386 lb counterweight													
360° Rating													
Radius ft	lb x 1000												
	Boom length ft												
	105	125	144	164	184	203	223	243	262	282	302	322	341
19	1433.0												
20	1241.0												
22	1150.4	1130.5	1107.8										
24	1071.9	1055.2	1036.0	1015.1									
26	1003.3	989.1	972.8	954.9	934.3								
28	942.8	930.6	916.6	901.2	883.4	863.4							
30	889.1	878.5	866.4	853.0	837.6	820.1	799.4						
32	841.0	831.9	821.3	809.6	796.0	780.8	762.5	744.0					
34	797.8	789.8	780.5	770.3	758.3	744.9	728.7	712.3	691.9	591.2			
36	758.8	751.7	743.5	734.5	723.9	712.0	697.6	682.9	667.7	586.6	483.9		
38	723.3	717.1	709.8	701.8	692.4	681.7	668.9	655.8	642.1	581.9	479.8	426.4	
40	690.9	685.4	678.9	671.8	663.4	653.9	642.3	630.5	618.1	577.2	475.8	423.9	357.7
45	613.7	617.0	612.1	606.7	600.2	592.9	583.9	574.8	565.0	555.8	465.7	416.3	350.6
50	528.0	534.2	539.1	544.8	547.7	542.0	534.9	527.6	519.8	512.4	455.9	408.5	344.1
55	462.9	468.4	472.9	477.9	481.8	486.6	489.4	487.3	480.9	474.9	446.3	401.0	337.8
60	411.8	416.8	420.9	425.4	428.9	433.2	435.7	439.8	441.6	442.3	436.0	393.6	331.6
65	370.6	375.3	378.9	383.1	386.3	390.2	392.4	396.1	397.8	401.5	403.1	386.5	325.6
70	336.7	341.0	344.4	348.2	351.2	354.7	356.8	360.2	361.7	365.1	366.5	370.2	319.4
75	308.3	312.4	315.6	319.1	321.8	325.1	327.0	330.1	331.5	334.6	335.9	339.3	313.7
80	284.2	288.0	291.0	294.3	296.8	299.9	301.6	304.5	305.8	308.7	309.9	313.0	308.0
85	263.5	267.1	269.9	273.0	275.3	278.2	279.8	282.5	283.7	286.4	287.5	290.5	291.4
90	245.4	248.9	251.5	254.4	256.7	259.3	260.9	263.4	264.5	267.0	268.1	270.8	271.7
95	229.6	232.9	235.4	238.2	240.3	242.8	244.3	246.6	247.7	250.0	251.0	252.1	251.0
100	215.6	218.7	221.2	223.8	225.8	228.2	229.6	231.8	232.8	235.0	235.9	233.0	231.9
105	203.1	206.1	208.5	211.0	212.9	215.1	216.5	218.5	219.5	219.7	219.3	215.9	214.8
110		194.9	197.1	199.5	201.3	203.4	204.7	206.7	207.6	204.5	204.1	200.5	199.4
115		184.7	186.9	189.1	190.9	192.9	194.2	193.7	193.9	190.7	190.3	186.7	185.6
120		175.4	177.6	179.7	181.4	183.4	184.6	181.3	181.4	178.2	177.8	174.2	173.1
125		167.0	169.1	171.2	172.8	173.5	173.3	170.0	170.1	166.8	166.4	162.8	161.7
130			161.4	163.4	165.0	163.2	163.0	159.6	159.7	156.4	156.0	152.3	151.3
135			154.3	156.2	156.5	153.7	153.5	150.1	150.2	146.9	146.4	142.8	141.7
140			147.7	148.8	147.8	144.9	144.7	141.3	141.4	138.1	137.6	133.9	132.9
145			141.6	140.6	139.6	136.8	136.6	133.2	133.3	130.0	129.5	125.8	124.7
150				133.0	132.1	129.2	129.0	125.6	125.7	122.4	121.9	118.2	117.1
155				125.8	125.0	122.2	122.0	118.6	118.7	115.4	114.9	111.2	110.1
160				119.1	118.4	115.7	115.5	112.1	112.2	108.9	108.4	104.6	103.6
165					112.2	109.5	109.4	106.0	106.1	102.7	102.2	98.5	97.5
170					106.4	103.8	103.6	100.3	100.4	97.0	96.5	92.8	91.7
175					100.9	98.3	98.3	94.9	95.0	91.6	91.1	87.4	86.3
180					95.6	93.2	93.2	89.8	89.9	86.6	86.1	82.3	81.3
185						88.4	88.4	85.1	85.2	81.8	81.3	77.6	76.5
190						83.8	83.8	80.5	80.7	77.3	76.8	73.1	72.0
195						79.4	79.5	76.3	76.4	73.1	72.6	68.8	67.8
200						75.1	75.4	72.2	72.4	69.0	68.5	64.8	63.7
205							71.5	68.3	68.5	65.2	64.7	60.9	59.9
210							67.8	64.7	64.9	61.5	61.1	57.3	56.3
215							64.2	61.2	61.4	58.1	57.6	53.8	52.8
220							60.7	57.8	58.1	54.8	54.3	50.5	49.5
225								54.6	54.9	51.6	51.2	47.4	46.4
230								51.5	51.9	48.6	48.2	44.4	43.4
235								48.5	49.0	45.7	45.3	41.5	40.6
240								45.6	46.2	42.9	42.5	38.8	37.8
245									43.5	40.3	39.9	36.1	35.2
250									40.9	37.7	37.4	33.6	32.7
255									38.3	35.3	34.9	31.2	30.3
260										32.9	32.6	28.9	27.9
265										30.6	30.3	26.6	25.7
270										28.4	28.1	24.5	23.6
275										26.2	24.2	22.4	21.5
280											20.4	20.3	19.5
285											16.6	18.4	17.6
290												16.5	15.7

For complete chart, refer to www.cranelibrary.com.

Extended UBP range diagram

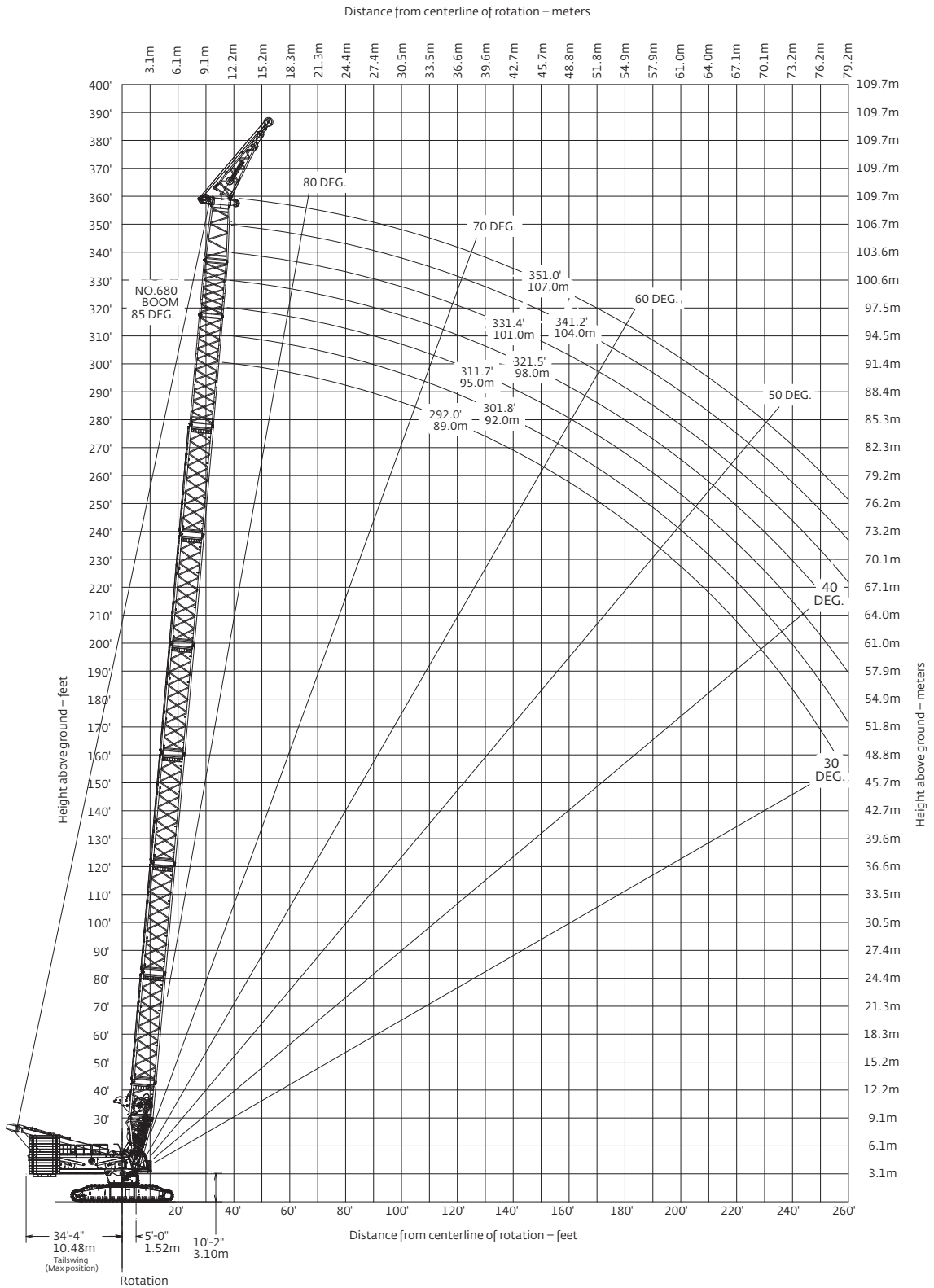

Extended UBP load charts

No. 680-681 WA boom with 24.9 ft extended UBP							
661,386 lb counterweight							
360° Rating							
Radius ft	lb x 1000						
	28° Offset						
	Boom length ft						
	292	302	312	322	331	341	351
45	292.8						
50	292.8	292.8	292.8	292.8	292.8	292.3	273.0
55	292.8	292.8	292.8	292.8	292.8	287.8	268.7
60	292.8	292.8	292.8	292.8	292.8	283.3	264.4
65	292.8	292.8	292.8	292.8	292.8	278.8	260.1
70	292.8	292.8	292.8	289.7	292.8	274.5	255.9
75	292.8	292.8	292.8	283.3	287.3	267.5	250.0
80	292.8	292.8	292.8	277.1	280.9	261.0	243.7
85	292.1	292.8	292.0	271.3	274.8	254.8	237.6
90	272.6	274.1	274.8	265.7	268.9	249.0	231.7
95	255.5	256.9	257.6	258.6	259.1	243.4	226.1
100	240.3	241.7	242.3	243.3	243.7	238.0	220.8
105	226.8	228.1	228.7	229.6	230.1	228.4	215.7
110	214.8	215.9	216.1	214.4	214.4	212.7	210.9
115	203.9	202.5	202.0	200.3	200.3	198.5	198.0
120	191.8	189.7	189.2	187.5	187.4	185.7	185.1
125	180.2	178.1	177.5	175.8	175.8	174.0	173.4
130	169.6	167.4	166.9	165.2	165.1	163.4	162.7
135	159.8	157.7	157.1	155.4	155.3	153.5	152.9
140	150.8	148.7	148.1	146.4	146.3	144.5	143.9
145	142.5	140.4	139.8	138.0	138.0	136.2	135.5
150	134.9	132.6	132.1	130.3	130.2	128.4	127.8
155	127.7	125.5	124.9	123.1	123.0	121.2	120.6
160	121.0	118.8	118.2	116.4	116.3	114.5	113.9
165	114.8	112.5	111.9	110.2	110.1	108.2	107.6
170	108.9	106.7	106.1	104.3	104.2	102.4	101.7
175	103.5	101.2	100.6	98.8	98.7	96.8	96.2
180	98.3	96.0	95.4	93.6	93.5	91.7	91.0
185	93.4	91.1	90.5	88.7	88.6	86.8	86.1
190	88.8	86.5	85.9	84.1	84.0	82.2	81.5
195	84.5	82.2	81.6	79.8	79.7	77.8	77.1
200	80.4	78.1	77.5	75.6	75.5	73.7	73.0
205	76.5	74.1	73.5	71.7	71.6	69.8	69.1
210	72.8	70.4	69.8	68.0	67.9	66.0	65.4
215	69.2	66.9	66.3	64.5	64.4	62.5	61.8
220	65.9	63.5	62.9	61.1	61.0	59.1	58.5
225	62.7	60.3	59.7	57.9	57.8	55.9	55.2
230	59.6	57.2	56.6	54.8	54.7	52.8	52.2
235	56.7	54.3	53.7	51.9	51.8	49.9	49.2
240	53.8	51.5	50.9	49.1	49.0	47.1	46.4
245	51.1	48.8	48.2	46.4	46.3	44.4	43.7
250	48.6	46.2	45.6	43.8	43.7	41.8	41.2
255	46.1	43.7	43.1	41.3	41.2	39.3	38.7
260	43.7	41.3	40.7	38.9	38.8	37.0	36.3
265	41.4	39.0	38.4	36.6	36.6	34.7	34.0
270	39.1	36.8	36.2	34.4	34.3	32.5	31.8
275	37.0	34.6	34.1	32.3	32.2	30.3	29.7
280	34.9	32.6	32.0	30.2	30.2	28.3	27.7
285	32.9	30.6	30.0	28.3	28.2	26.3	25.7
290	30.1	28.6	28.1	26.3	26.3	24.4	23.8
295	25.0	26.7	26.2	24.5	24.4	22.6	21.9
300	20.0	24.9	24.4	22.7	22.6	20.8	20.1
305	15.0	23.1	22.7	20.9	20.9	19.0	18.4
310		21.4	20.9	19.2	19.2	17.4	16.7
315		18.4	19.3	17.6	17.6	15.7	15.1
320		15.0	16.9	15.9	16.0		

No. 680-681 WA boom with 24.9 ft extended UBP							
661,386 lb counterweight							
360° Rating							
Radius ft	lb x 1000						
	35° Offset						
	Boom length ft						
	292	302	322	331	341	351	
50	292.8	292.8	292.8				
55	292.8	292.8	292.8	292.8	280.3	256.6	
60	292.8	292.8	287.6	290.2	273.3	256.6	
65	292.8	292.8	281.3	283.7	266.5	251.3	
70	292.8	292.8	275.3	277.5	260.1	244.8	
75	292.8	292.8	269.6	271.6	254.1	238.6	
80	292.8	292.8	264.1	265.9	248.3	232.7	
85	292.3	292.8	259.0	260.6	242.7	227.1	
90	272.8	274.3	254.0	255.4	237.5	221.8	
95	255.6	257.0	249.3	250.5	232.4	216.7	
100	240.5	241.8	243.4	243.9	227.6	211.9	
105	227.0	228.2	229.8	230.2	223.0	207.3	
110	214.9	216.1	216.0	216.0	214.4	202.9	
115	204.0	203.9	201.8	201.8	200.1	198.6	
120	193.0	191.1	188.9	188.9	187.2	186.6	
125	181.4	179.3	177.2	177.1	175.4	174.9	
130	170.7	168.6	166.4	166.4	164.7	164.1	
135	160.9	158.8	156.6	156.5	154.8	154.2	
140	151.9	149.7	147.5	147.4	145.7	145.1	
145	143.5	141.4	139.1	139.0	137.3	136.7	
150	135.8	133.6	131.3	131.3	129.5	128.9	
155	128.5	126.4	124.1	124.0	122.2	121.6	
160	121.8	119.6	117.3	117.3	115.5	114.9	
165	115.6	113.3	111.0	111.0	109.2	108.5	
170	109.7	107.4	105.1	105.0	103.2	102.6	
175	104.1	101.9	99.6	99.5	97.7	97.1	
180	99.0	96.7	94.4	94.3	92.5	91.8	
185	94.1	91.8	89.4	89.4	87.5	86.9	
190	89.4	87.2	84.8	84.7	82.9	82.3	
195	85.1	82.8	80.4	80.3	78.5	77.9	
200	80.9	78.6	76.3	76.2	74.3	73.7	
205	77.0	74.7	72.3	72.2	70.4	69.7	
210	73.2	70.9	68.6	68.5	66.6	66.0	
215	69.7	67.4	65.0	64.9	63.1	62.4	
220	66.3	64.0	61.6	61.5	59.7	59.0	
225	63.0	60.7	58.4	58.3	56.4	55.8	
230	59.9	57.6	55.3	55.2	53.3	52.7	
235	57.0	54.7	52.3	52.2	50.4	49.7	
240	54.1	51.8	49.5	49.4	47.5	46.9	
245	51.4	49.1	46.8	46.7	44.8	44.2	
250	48.8	46.5	44.1	44.1	42.2	41.6	
255	46.3	44.0	41.6	41.6	39.7	39.1	
260	43.9	41.6	39.2	39.2	37.3	36.7	
265	41.5	39.2	36.9	36.9	35.0	34.4	
270	39.3	37.0	34.7	34.6	32.8	32.2	
275	37.1	34.8	32.5	32.5	30.6	30.0	
280	35.0	32.7	30.5	30.4	28.6	27.9	
285	33.0	30.7	28.4	28.4	26.6	26.0	
290	30.6	28.7	26.5	26.5	24.6	24.0	
295	25.3	26.8	24.6	24.6	22.8	22.2	
300	20.1	24.9	22.8	22.8	21.0	20.4	
305		23.1	21.0	21.0	19.2	18.6	
310		21.3	19.3	19.3	17.5	16.9	
315		18.3	17.6	17.7	15.9	15.3	
320			16.0	16.0			

Luffing jib range diagram

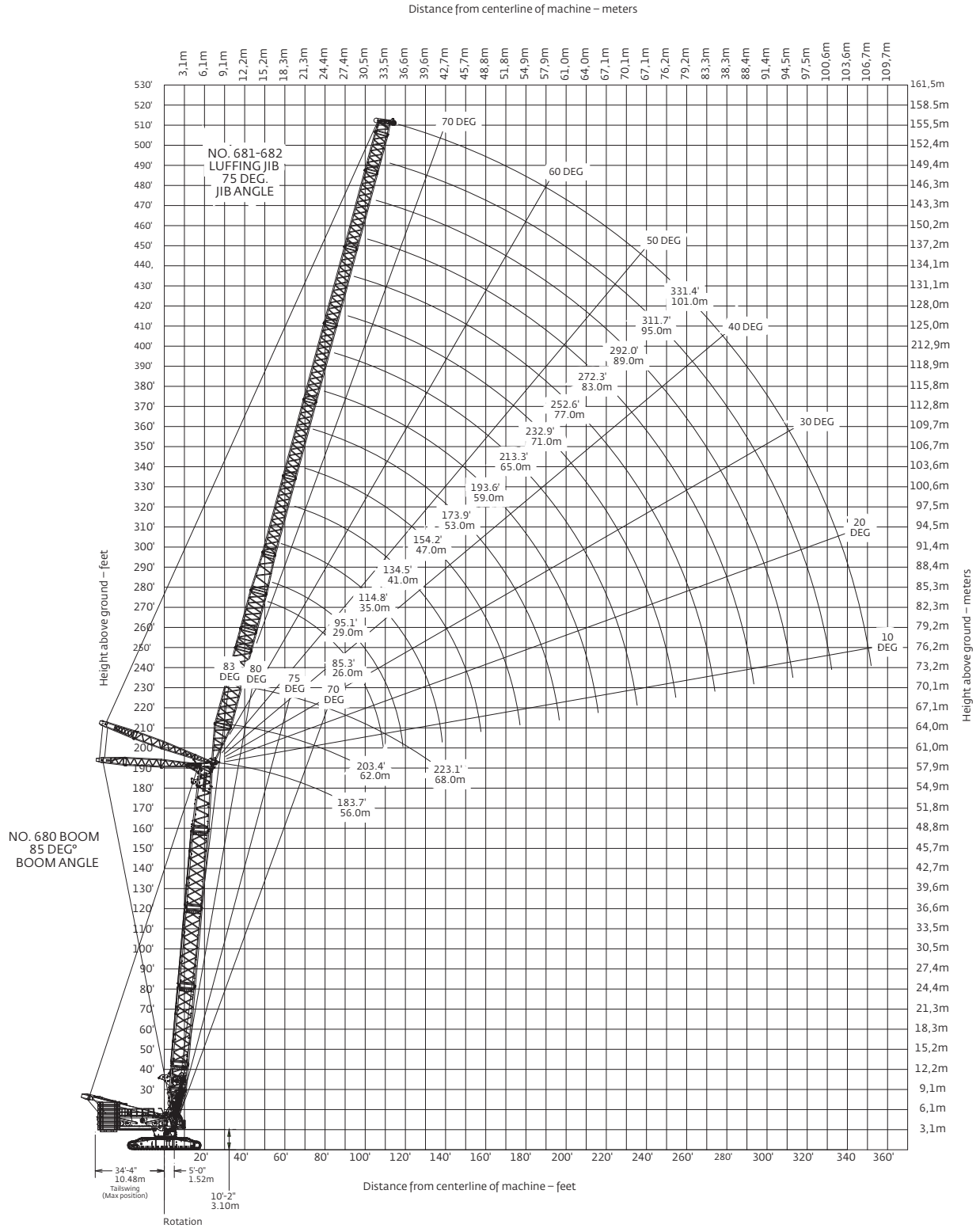

Luffing jib load charts

No. 681-682 luffing jib on No. 680 boom

661,386 lb counterweight

360° Rating

lb x 1000

85° boom angle

115 ft luffing jib length					
Radius ft	Boom length ft				
	144	164	184	203	223
55	502.1				
60	466.5	463.7	455.2	448.0	
65	426.4	432.4	426.1	420.1	395.4
70	388.3	393.8	394.6	395.3	383.3
75	356.5	361.5	362.2	365.4	366.9
80	329.4	334.0	334.7	337.6	339.1
85	306.1	310.4	311.0	313.8	315.1
90	285.8	289.9	290.4	293.0	294.2
95	268.0	271.8	272.4	274.8	276.0
100	252.3	255.9	256.4	258.7	259.8
105	238.3	241.7	242.2	244.3	245.4
110	225.8	229.0	229.4	231.5	232.5
115	214.4	217.5	217.9	219.9	220.8
120	204.2	207.1	207.5	209.4	210.3
125	194.8	197.6	198.0	199.8	200.6
130	186.3	188.9	189.3	191.0	191.9
135	178.4	181.0	181.4	183.0	183.8
140				175.5	174.8

154 ft luffing jib length					
Radius ft	Boom length ft				
	144	164	184	203	223
70	392.2	397.7	392.8		
75	360.0	365.1	365.8	357.0	296.7
80	332.7	337.3	338.0	340.9	295.1
85	309.1	313.5	314.1	316.8	292.8
90	288.7	292.7	293.3	295.8	290.1
95	270.7	274.5	275.0	277.4	278.6
100	254.8	258.4	258.9	261.2	262.3
105	240.7	244.1	244.6	246.7	247.7
110	228.0	231.2	231.7	233.7	234.7
115	216.6	219.6	220.1	222.0	222.9
120	206.2	209.1	209.5	211.4	212.0
125	196.8	199.6	200.0	201.7	200.9
130	188.2	190.8	191.2	192.0	190.7
135	180.3	182.8	183.2	182.5	181.3
140	173.0	175.4	175.0	173.8	172.6
145	166.3	168.6	166.9	165.7	164.6
150	160.0	161.1	159.3	158.2	157.2
155	154.0	154.0	152.3	151.2	150.2
160	147.4	147.4	145.7	144.7	143.7
165	141.0	141.1	139.5	138.5	137.6
170	135.0	135.1	133.6	132.7	131.8
175	128.8	129.3	127.9	127.1	126.3
180				121.4	120.9

For complete chart, refer to www.cranelibrary.com.

Luffing jib load charts

No. 681-682 luffing jib on No. 680 boom

661,386 lb counterweight

360° Rating

lb x 1000

85° boom angle

194 ft luffing jib length				
Radius ft	Boom length ft			
	144	164	184	203
80	335.9	327.3	296.8	
85	312.1	316.4	296.5	268.1
90	291.5	295.5	296.0	265.8
95	273.3	277.1	277.6	264.9
100	257.3	260.8	261.3	263.6
105	243.0	246.4	246.8	248.9
110	230.2	233.4	233.8	235.0
115	218.6	221.7	222.1	221.4
120	208.2	211.1	210.7	209.2
125	198.7	201.4	199.4	198.0
130	190.0	191.4	189.1	187.7
135	182.0	181.9	179.7	178.4
140	173.2	173.1	171.0	169.7
145	165.1	164.9	162.9	161.7
150	157.5	157.4	155.4	154.3
155	150.5	150.4	148.5	147.3
160	143.9	143.8	142.0	140.9
165	137.8	137.7	135.9	134.9
170	132.0	131.9	130.2	129.2
175	126.6	126.5	124.9	123.9
180	121.5	121.4	119.8	118.9
185	116.7	116.6	115.1	114.1
190	112.1	112.0	110.6	109.7
195	107.8	107.7	106.3	105.4
200	103.6	103.6	102.2	101.4
205	99.6	99.6	98.3	97.5
210	95.8	95.8	94.5	93.8
215		91.9	90.8	90.1

For complete chart, refer to www.cranelibrary.com.

Luffing jib load charts

No. 681-682 luffing jib on No. 680 boom

661,386 lb counterweight

360° Rating

lb x 1000

85° boom angle

253 ft luffing jib length				
Radius ft	Boom length ft			
	144	164	184	203
95	215.9	202.9	188.9	
100	215.4	201.8	187.9	173.2
105	214.8	201.4	187.5	172.8
110	214.2	200.9	187.1	171.9
115	213.5	200.3	186.5	171.4
120	205.5	199.7	186.0	170.8
125	194.1	193.8	185.4	170.2
130	183.7	183.4	181.0	169.6
135	174.2	173.9	171.5	168.9
140	165.4	165.1	162.9	161.5
145	157.2	157.0	154.8	153.5
150	149.7	149.4	147.4	146.1
155	142.7	142.4	140.5	139.2
160	136.2	135.9	134.0	132.8
165	130.1	129.8	128.0	126.8
170	124.3	124.1	122.3	121.2
175	119.0	118.8	117.0	115.9
180	113.9	113.7	112.0	111.0
185	109.2	109.0	107.3	106.3
190	104.7	104.5	102.9	101.9
195	100.4	100.2	98.7	97.7
200	96.4	96.2	94.7	93.8
205	92.6	92.4	90.9	90.0
210	88.9	88.8	87.3	86.4
215	85.5	85.3	83.9	83.0
220	82.2	82.0	80.7	79.8
225	79.0	78.9	77.5	76.7
230	76.0	75.9	74.6	73.8
235	73.1	73.0	71.7	70.9
240	70.3	70.2	69.0	68.2
245	67.7	67.6	66.4	65.6
250	65.1	65.0	63.8	63.1
255	62.6	62.5	61.4	60.7
260	60.2	60.1	59.0	58.3
265	57.9	57.8	56.7	56.1
270	55.5	55.5	54.5	53.8
275		53.0	52.2	51.6

For complete chart, refer to www.cranelibrary.com.

Outline dimensions

VPC-MAX

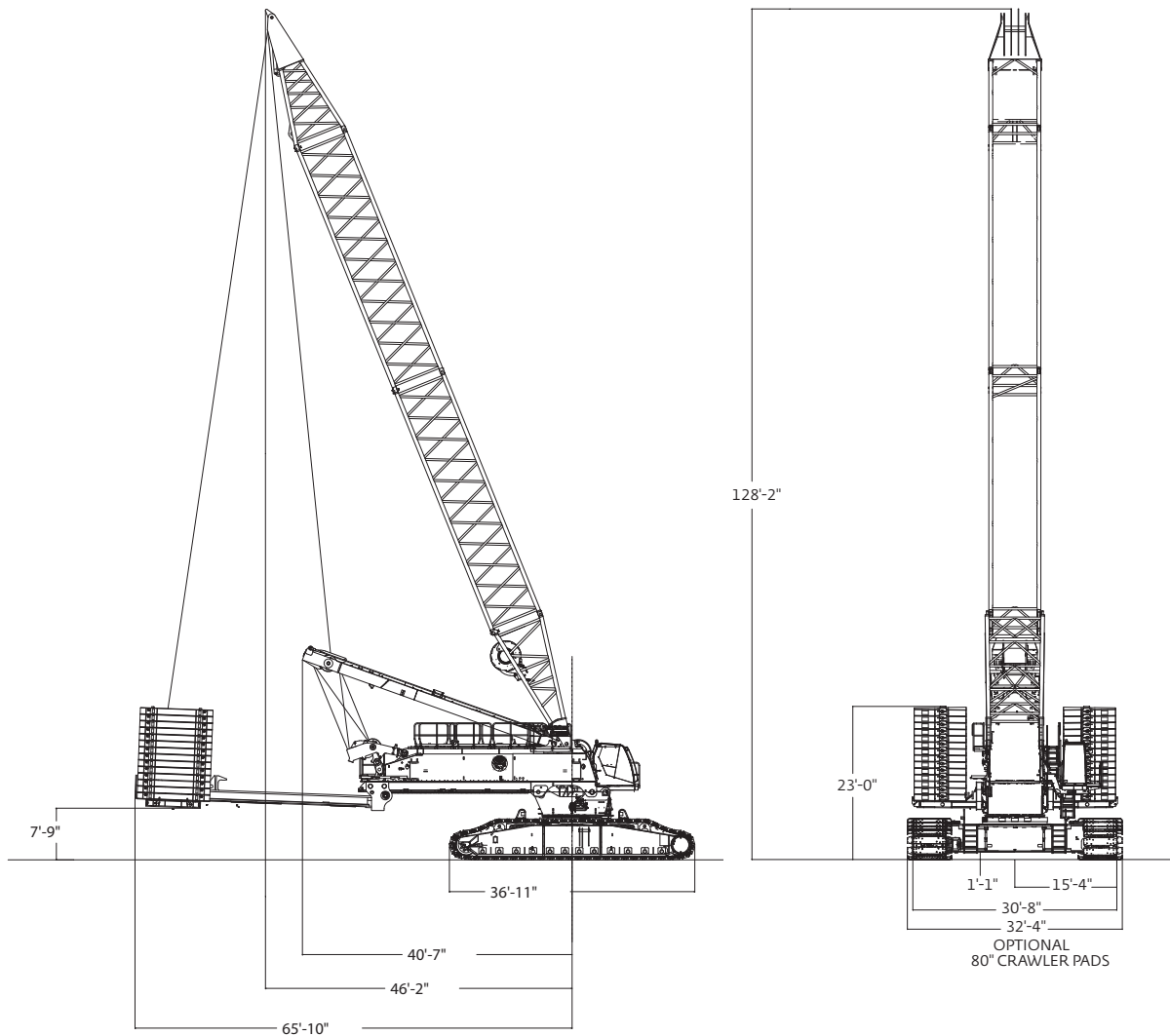
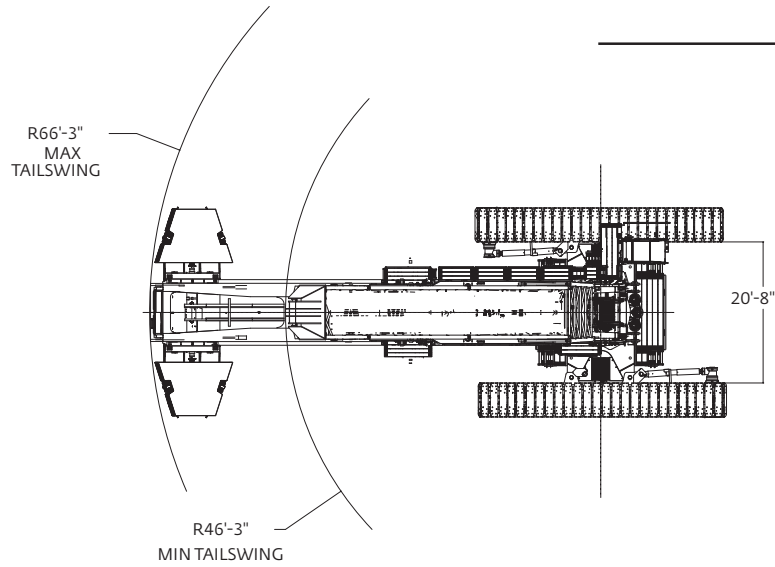

Transport data

VPC-MAX

Load summary																						
Item	Qty	Weight lb	282 ft boom																			
			Quantity on trailer load #																			
			(Does not include blocking, strapping, etc.)																			
			1	2	3	4	5	6	7	8	9	10	11	12	13	14	15	16	17	18	19	20
Upperworks module	1	85,950	1																			
Whip hoist	1	12,500									1											
Live mast package	1	59,400		1																		
Carbody + adapter	1	92,300			1																	
Crawler assembly (60" pads)	2	86,000				1	1															
Counterweight tray	1	44,000						1														
Counterweight box	28	22,046															2	2	2	2	2	
Boom butt with drum 1	1	43,150							1													
13' 1" No. 680 boom insert with drum 2	1	39,460								1												
39' 4" No. 680 heavy boom insert	1	27,150									1											
39' 4" No. 680 heavy boom insert	1	21,460										1										
39' 4" No. 680 heavy boom insert with equalizer rails	1	23,140											1									
19' 8" heavy boom insert	1	12,520												1								
39' 4" medium insert with suspension	1	22,740													1							
39' 4" medium insert	1	17,560														1						
32' 10" boom top	1	41,550															1					
350 t block (32 mm)	1	17,400												1								
22,2 mt weight ball	1	2,800										1										
VPC-MAX beam	1	47,000																				
VPC-MAX actuator	1	10,000												1								
Fixed mast 19' 7" butt + 19' 7" top	1	56,700																				
39' 4" mast insert	2	15,230																				
VPC-MAX counterweight box	10	22,046																				
Approximate total shipping weight lb			85,950	59,400	92,300	86,000	86,000	44,000	43,150	39,460	39,650	24,260	23,140	39,920	22,740	17,560	41,550	44,092	44,092	44,092	44,092	

Transport data

VPC-MAX

(continued)

Load summary																				
Item	Qty	Weight lb	282 ft boom																	
			Quantity on trailer load #																	
			(Does not include blocking, strapping, etc.)																	
			21	22	23	24	25	26	27	28	29	30	31	32	33	34	35	36	37	
Upperworks module	1	85,950																		
Whip hoist	1	12,500																		
Live mast package	1	59,400																		
Carbody + adapter	1	92,300																		
Crawler assembly (60" pads)	2	86,000																		
Counterweight tray	1	44,000																		
Counterweight box	28	22,046	2	2	2	2	2	2	2	2	2									
Boom butt with drum 1	1	43,150																		
13' 1" No. 680 boom insert with drum 2	1	39,460																		
39' 4" No. 680 heavy boom insert	1	27,150																		
39' 4" No. 680 heavy boom insert	1	21,460																		
39' 4" No. 680 heavy boom insert with equalizer rails	1	23,140																		
19' 8" heavy boom insert	1	12,520																		
39' 4" medium insert with suspension	1	22,740																		
39' 4" medium insert	1	17,560																		
32' 10" boom top	1	41,550																		
350 t block (32 mm)	1	17,400																		
22,2 mt weight ball	1	2,800																		
VPC-MAX beam	1	47,000										1								
VPC-MAX actuator	1	10,000																		
Fixed mast 19' 7" butt + 19' 7" top	1	56,700											1							
39' 4" mast insert	2	15,230												1	1					
VPC-MAX counterweight box	10	22,046												1	1	2	2	2	2	
Approximate total shipping weight lb			44,092	44,092	44,092	44,092	44,092	44,092	44,092	44,092	44,092	44,092	47,000	56,700	37,276	37,276	44,092	44,092	44,092	44,092

Boom combinations

VPC-MAX

No. 680 VPC-MAX main boom combinations					
Boom length ft	Main boom inserts ft				
	13.1 XH	19.7 H	39.4 XH	39.4 H	39.4 M
144.4	1	0	1	1	0
164	1	1	1	1	0
183.7	1	0	2	1	0
203.4	1	1	2	1	0
223.1	1	0	2	1	1
242.8	1	1	2	1	1
262.5	1	0	2	2	1
282.2	1	1	2	2	1
301.8	1	0	2	3	1
321.5	1	1	2	3	1
341.2	1	0	2	4	1
360.9	1	1	2	4	1
380.6	1	0	2	4	2
400.3	1	1	2	4	2
419.9	1	0	2	4	3
439.6	1	1	2	4	3
459.3	1	0	2	4	4

XH: Extra heavy insert
H: Heavy insert
M: Medium insert

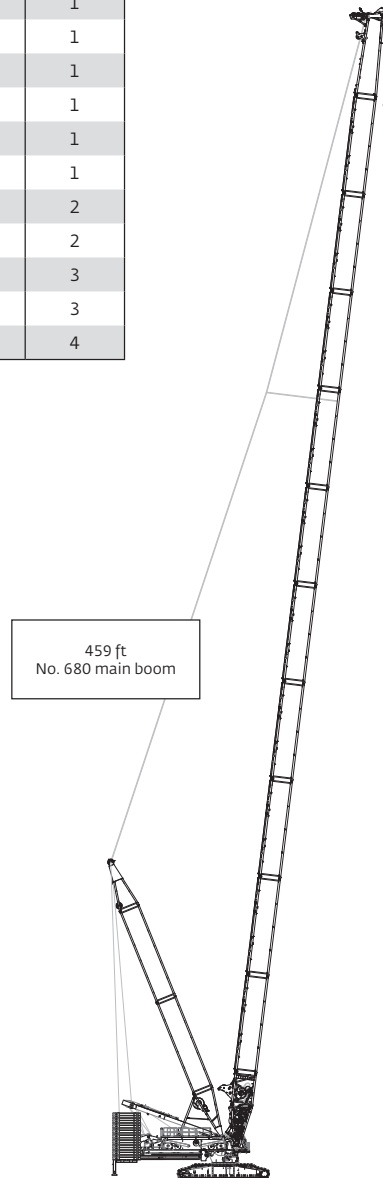

Boom combinations

VPC-MAX

No. 681-682 VPC-MAX luffing jib combinations					
Luffing jib length ft	Luffing jib inserts ft				
	9.8	19.7	19.7*	39.4	39.4*
85.3	0	0	0	1	0
95.1	1	0	0	1	0
114.8	1	1	0	1	0
134.5	1	0	0	2	0
154.2	1	1	0	2	0
173.9	1	1	1	2	0
193.6	1	1	0	2	1
213.3	1	1	1	2	1
232.9	1	1	0	2	2
252.6	1	1	1	2	2
272.3	1	1	0	2	3
292	1	1	1	2	3
311.7	1	1	0	2	4
331.4	1	1	1	2	4

* Shallow inserts

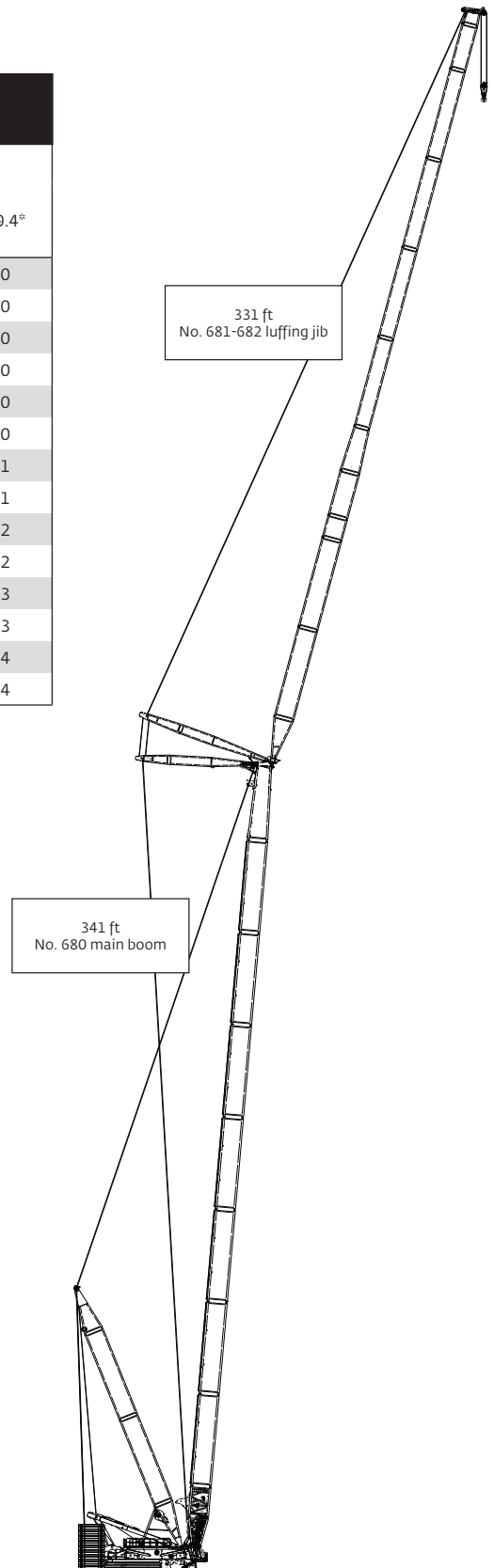

Main boom range diagram

VPC-MAX

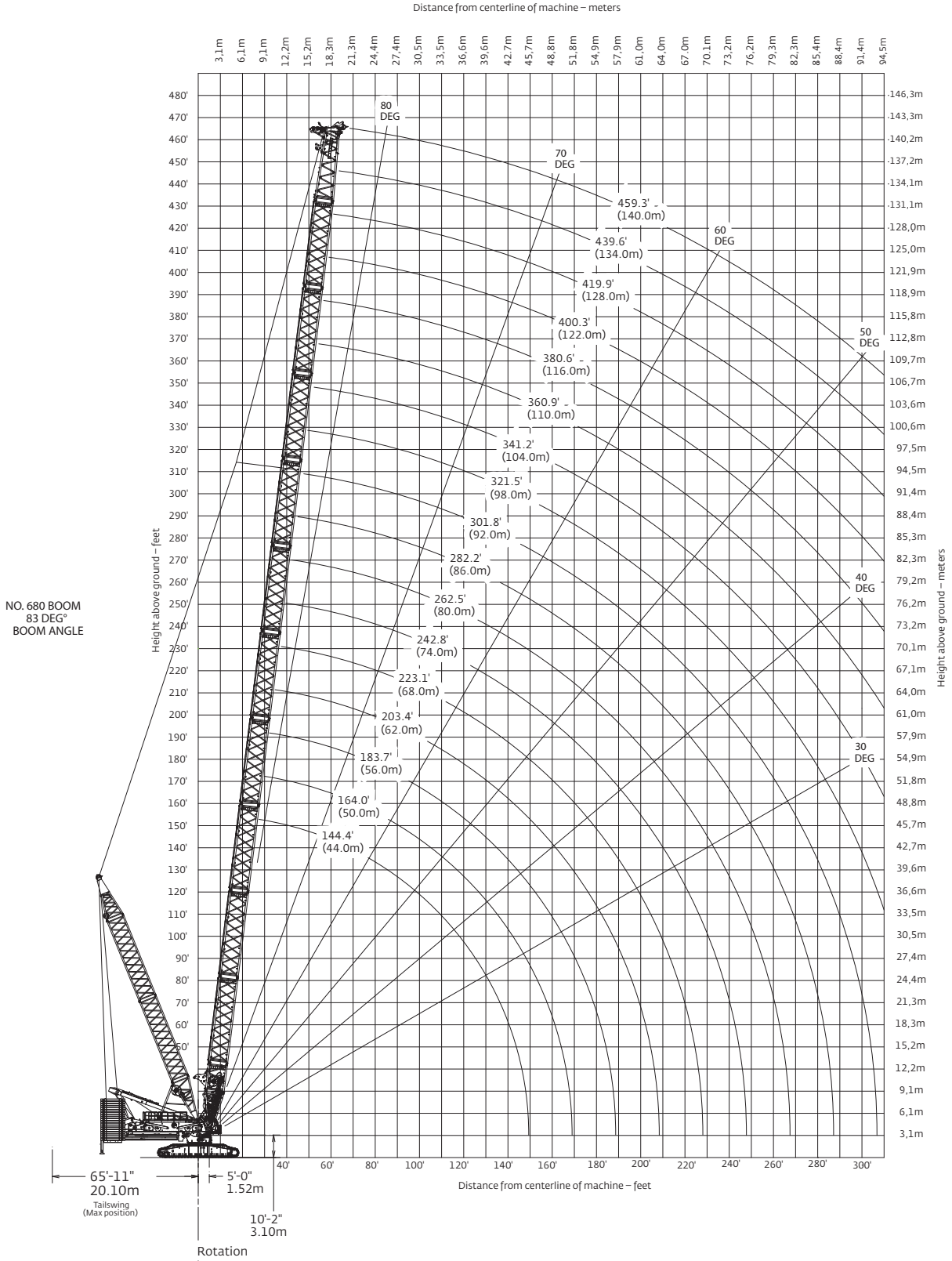

Main boom load charts

VPC-MAX

No. 680 boom VPC-MAX																
881,848 lb counterweight																
360° Rating																
Radius ft	lb x 1000															
	Boom length ft															
	144	164	184	203	223	243	262	282	302	322	341	361	381	400	420	440
28	1543.2															
30	1466.3															
32	1428.4	1356.6														
34	1392.3	1323.8	1257.6													
36	1392.3	1292.4	1229.2	1164.2												
38	1392.3	1286.7	1201.9	1139.6	1084.1											
40	1392.3	1286.7	1184.6	1116.0	1062.9	999.2										
45	1392.3	1286.7	1184.6	1116.0	1012.8	955.1	842.0	720.3								
50	1309.5	1286.7	1184.6	1116.0	1012.8	938.9	842.0	720.3	601.6	525.1						
55	1189.5	1186.0	1183.1	1116.0	1012.8	938.9	842.0	720.3	601.6	525.1	443.3	391.9				
60	1088.7	1085.3	1082.4	1078.8	1012.8	938.9	842.0	720.3	601.6	525.1	443.3	391.9	332.4	296.5		
65	1002.9	999.6	996.8	993.1	990.7	938.9	842.0	720.3	601.6	525.1	443.3	391.9	331.0	296.5	265.3	237.6
70	929.1	925.8	923.0	919.3	919.5	905.5	842.0	720.3	601.6	525.1	443.3	391.9	330.1	296.1	265.3	237.6
75	864.8	861.5	858.7	855.1	855.2	849.7	835.9	720.3	601.6	525.1	443.1	391.9	328.9	295.0	264.9	237.5
80	808.2	805.0	802.3	798.6	798.8	795.0	787.7	720.3	601.6	525.1	441.4	391.5	327.6	293.8	263.9	237.4
85	758.2	755.0	752.4	748.7	748.8	745.0	744.0	720.3	601.6	525.1	439.5	390.1	326.4	292.6	262.9	237.2
90	713.6	710.4	707.8	704.1	704.3	700.4	700.1	691.5	599.7	523.9	437.5	388.6	325.1	291.8	261.8	236.2
95	673.6	670.4	667.8	664.1	664.3	660.4	660.2	656.2	590.8	521.6	435.5	387.1	323.8	290.7	260.9	235.2
100	637.4	634.4	631.8	628.0	628.3	624.4	624.1	620.1	576.9	519.1	433.4	385.6	322.5	289.4	260.0	234.2
105	602.3	600.3	598.5	595.3	595.6	591.7	591.4	587.4	563.1	511.8	431.3	384.0	321.1	288.2	258.9	233.4
110	567.9	565.9	564.1	561.5	562.4	559.6	559.9	556.9	549.5	498.7	421.2	382.4	319.7	287.0	257.8	232.4
115	536.9	534.9	533.1	530.5	531.3	528.5	528.7	525.8	525.4	486.0	410.7	380.8	318.4	285.7	256.8	231.4
120	508.8	506.8	505.0	502.4	503.2	500.3	500.5	497.5	497.2	473.3	400.2	379.1	317.0	284.5	255.6	230.4
125	483.1	481.2	479.4	476.7	477.5	474.6	474.8	471.8	471.4	461.0	389.9	377.4	315.6	283.2	254.5	229.3
130	459.6	457.8	456.0	453.3	454.1	451.1	451.3	448.3	447.9	444.8	379.8	375.7	314.1	281.9	253.4	228.3
135	438.1	436.2	434.5	431.8	432.5	429.6	429.8	426.7	426.3	423.2	369.7	374.0	312.7	280.6	252.3	227.2
140	418.1	416.4	414.7	411.9	412.7	409.7	409.9	406.8	406.4	403.3	359.9	372.3	311.3	279.3	251.2	226.2
145	399.6	398.0	396.4	393.6	394.4	391.4	391.5	388.4	388.0	384.9	350.2	370.5	309.8	278.0	250.0	225.1
150		381.0	379.4	376.6	377.4	374.3	374.5	371.4	371.0	367.8	340.7	363.4	308.4	276.7	248.9	224.1
155		365.1	363.6	360.8	361.5	358.5	358.7	355.5	355.1	351.9	331.3	347.4	306.9	275.4	247.7	223.0
160		350.3	348.8	346.0	346.8	343.7	343.9	340.8	340.3	337.1	322.1	332.6	305.4	274.0	246.6	222.0
165			335.0	332.3	333.0	330.0	330.1	327.0	326.5	323.3	313.0	318.8	303.4	272.7	245.4	220.9
170			322.1	319.3	320.1	317.0	317.2	314.0	313.6	310.4	304.1	305.8	299.6	271.4	244.2	219.8
175			309.9	307.2	308.0	304.9	305.1	301.9	301.5	298.2	295.3	293.6	292.5	270.0	243.1	218.7
180			298.4	295.8	296.6	293.5	293.7	290.5	290.1	286.8	285.9	282.2	281.0	268.7	241.9	217.7
185				285.0	285.8	282.8	282.9	279.7	279.3	276.0	275.2	271.4	270.3	266.8	240.7	216.6
190				274.8	275.7	272.6	272.8	269.6	269.2	265.9	265.0	261.2	260.1	256.6	239.5	215.5
195				265.1	266.1	263.0	263.2	260.0	259.6	256.3	255.4	251.6	250.5	247.0	238.4	215.5
200				255.9	256.9	253.9	254.1	250.9	250.5	247.2	246.3	242.5	241.4	237.9	235.1	209.0
205					248.3	245.3	245.5	242.3	241.9	238.6	237.7	233.9	232.7	229.2	226.5	204.6
210					240.0	237.1	237.3	234.1	233.7	230.4	229.5	225.7	224.5	221.0	218.3	200.4
215					232.2	229.2	229.5	226.3	225.9	222.6	221.7	217.9	216.7	213.2	210.5	196.4
220						224.6	221.8	222.1	218.9	218.5	215.2	214.3	210.5	209.3	205.8	192.5
225							214.7	215.0	211.8	211.4	208.1	207.3	203.4	202.3	198.7	188.7
230							207.8	208.2	205.0	204.7	201.3	200.5	196.7	195.5	192.0	185.0
235							201.3	201.7	198.6	198.2	194.9	194.1	190.2	189.1	185.5	179.2
240							195.0	195.5	192.4	192.0	188.7	187.9	184.0	182.9	179.4	173.0
245								189.6	186.4	186.1	182.8	182.0	178.1	177.0	173.5	167.1
250								183.8	180.8	180.4	177.1	176.3	172.5	171.3	167.8	161.4
255								178.3	175.3	175.0	171.7	170.9	167.0	165.9	162.4	156.0
260									170.0	169.8	166.5	165.7	161.8	160.7	157.2	150.8
265									165.0	164.7	161.5	159.3	156.8	155.7	152.2	145.8
270									160.1	159.9	156.6	152.7	152.0	150.9	147.4	141.0
275										155.2	152.0	146.1	147.4	146.2	142.7	136.4
280										150.7	147.5	139.6	142.9	141.8	138.3	131.9
285										146.3	143.1	133.3	138.6	137.5	134.0	127.6
290										142.1	139.0	126.9	134.4	133.3	129.8	123.5
295										138.0	134.9	120.5	130.4	129.3	125.8	119.5
300											131.0	114.2	126.5	125.5	121.9	115.6
305											124.7	108.0	122.8	121.7	118.2	111.9
310											116.5	101.7	119.1	118.1	114.6	108.3
315												107.7	95.3	115.6	114.6	108.4
320													89.0	112.2	111.2	105.0
325														82.5	108.9	104.4
330															75.9	101.2
335																68.9
340																
345																
350																
355																
360																
365																
370																
375																
380																
385																
390																
395																
400																
405																
410																
415																
420																
425																
430																

Luffing jib range diagram

VPC-MAX

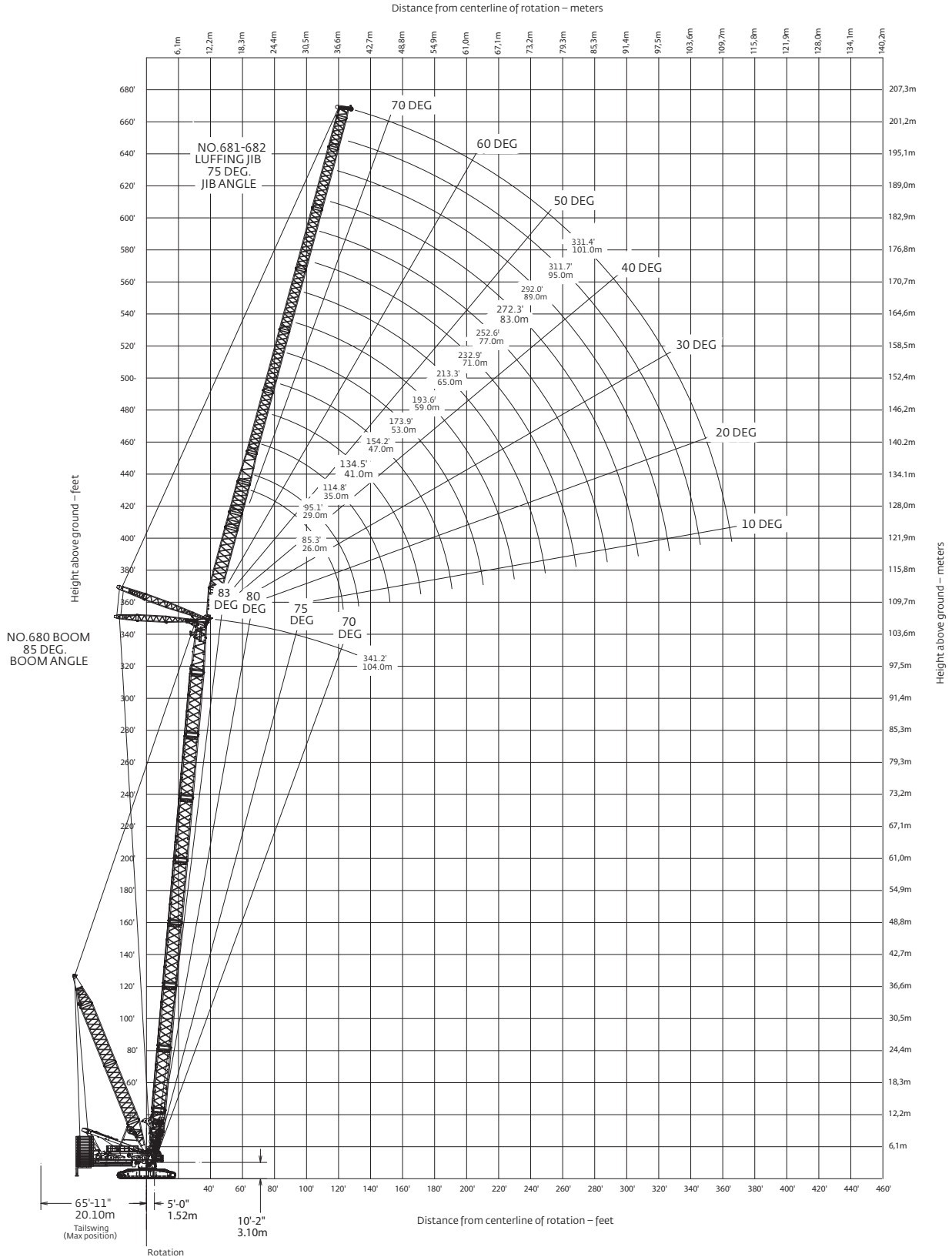

Luffing jib load charts

VPC-MAX

No. 681-682 luffing jib on No. 680 boom VPC-MAX

881,848 lb counterweight

360° Rating

lb x 1000

85° boom angle

115 ft luffing jib length					
Radius ft	Boom length ft				
	184	223	262	302	341
60	649.8				
65	633.4	450.2			
70	614.7	450.2	328.7	252.1	
75	595.8	445.4	327.5	243.3	189.9
80	577.1	429.8	325.2	239.3	187.2
85	558.8	402.9	322.1	237.6	178.0
90	539.2	379.3	318.5	235.2	175.1
95	510.2	358.7	311.4	232.5	173.4
100	482.4	340.6	299.1	229.7	171.5
105	456.1	324.6	287.1	227.0	169.4
110	431.7	310.8	275.7	222.3	167.5
115	409.4	298.8	264.8	214.6	165.7
120	389.5	288.6	254.8	207.2	163.1
125	362.5	280.3	245.8	200.6	161.4
130	316.0	274.3	238.1	194.6	156.8
135	267.8	271.2	232.0	189.6	152.9
140		262.4	228.7	186.1	149.6
145			228.7	184.8	147.6
150					147.6

194 ft luffing jib length					
Radius ft	Boom length ft				
	184	223	262	302	341
80	331.0				
85	331.0	254.0			
90	331.0	254.0	197.9	154.7	
95	331.0	254.0	197.9	150.6	118.4
100	331.0	254.0	197.6	150.1	117.5
105	330.7	254.0	196.9	149.4	116.3
110	327.5	252.7	196.1	148.7	112.1
115	317.7	245.7	195.0	147.7	111.3
120	307.5	238.4	191.6	146.6	110.4
125	297.0	230.9	186.1	145.4	109.4
130	286.7	223.6	180.5	144.1	108.3
135	276.2	216.1	175.0	140.5	107.2
140	265.8	208.7	169.4	136.4	106.1
145	255.5	201.3	163.9	132.3	104.7
150	245.5	194.1	158.6	128.3	101.8
155	235.9	187.2	153.3	124.5	98.9
160	226.5	180.5	148.2	120.7	96.0
165	217.5	174.0	143.4	117.0	93.3
170	209.2	167.9	138.7	113.5	90.6
175	201.2	162.1	134.2	110.1	88.1
180	193.8	156.6	130.1	106.9	85.6
185	186.8	151.6	126.2	103.9	83.3
190	180.5	146.9	122.5	101.1	81.2
195	174.8	142.6	119.3	98.6	79.2
200	169.8	139.0	116.4	96.3	77.5
205	165.8	136.0	113.9	94.3	75.9
210	161.4	133.7	112.0	92.7	74.6
215	139.4	132.8	110.9	91.6	73.6
220		132.8	110.9	91.2	73.0
225				91.2	73.0
230					73.0

For complete chart, refer to www.cranelibrary.com.

Luffing jib load charts

VPC-MAX

No. 681-682 luffing jib on No. 680 boom VPC-MAX

881,848 lb counterweight

360° Rating

lb x 1000

85° boom angle

253 ft luffing jib length					
Radius ft	Boom length ft				
	184	223	262	302	341
95	203.2				
100	203.2	165.8			
105	203.1	165.7	134.0	105.1	
110	202.9	165.7	134.0	104.8	80.1
115	202.5	165.5	134.0	104.7	79.7
120	202.1	165.2	133.8	104.5	79.2
125	201.6	164.8	133.5	104.2	77.0
130	201.1	164.4	133.1	103.8	76.6
135	200.6	163.9	132.7	103.3	76.2
140	200.0	163.3	132.1	102.7	75.6
145	199.3	159.9	129.3	102.0	75.1
150	197.2	156.2	126.3	100.2	74.4
155	192.3	152.3	123.3	97.9	73.8
160	187.3	148.5	120.2	95.4	73.1
165	182.3	144.6	117.1	93.0	71.5
170	177.3	140.7	114.1	90.6	69.7
175	172.3	136.8	111.0	88.2	67.9
180	167.3	133.0	108.0	85.9	66.1
185	162.4	129.2	105.0	83.6	64.4
190	157.6	125.4	102.0	81.3	62.7
195	152.8	121.8	99.2	79.1	61.1
200	148.2	118.3	96.4	76.9	59.4
205	143.7	114.8	93.7	74.8	57.8
210	139.4	111.5	91.1	72.8	56.3
215	135.2	108.3	88.6	70.9	54.8
220	131.2	105.3	86.2	69.0	53.4
225	127.4	102.4	83.9	67.3	52.0
230	123.8	99.7	81.8	65.6	50.8
235	120.5	97.1	79.8	64.0	49.5
240	117.3	94.7	77.9	62.6	48.4
245	114.4	92.5	76.2	61.2	47.4
250	111.8	90.6	74.6	60.0	46.4
255	109.5	88.8	73.2	58.9	45.6
260	107.5	87.4	72.1	58.0	44.8
265	106.2	86.4	71.2	57.3	44.2
270	96.4	85.8	70.7	56.8	43.8
275	81.2	85.8	70.7	56.6	43.6
260		79.7	70.7	56.6	43.6
265				56.6	43.6
270					43.6

331 ft luffing jib length					
Radius ft	Boom length ft				
	184	223	262	302	341
115	108.9				
120	108.2	90.1			
125	107.8	89.9	75.9	60.9	
130	107.3	89.7	75.8	60.7	45.5
135	106.7	89.5	75.7	60.7	45.4
140	106.3	89.2	75.6	60.6	45.3
145	105.9	88.9	75.4	60.5	45.1
150	105.3	88.6	75.2	60.3	44.9
155	104.8	88.3	75.0	60.0	44.7
160	104.2	87.9	74.7	59.8	44.4
165	103.6	87.6	74.4	59.6	44.0
170	103.1	87.2	74.1	59.3	43.1
175	102.5	86.9	73.8	58.4	42.3
180	102.0	86.5	73.4	57.3	41.3
185	101.5	86.1	72.9	56.2	40.4
190	100.9	85.8	71.5	55.0	39.5
195	100.4	85.4	70.2	53.9	38.6
200	99.9	85.0	68.8	52.7	37.6
205	99.4	84.0	67.4	51.6	36.7
210	98.8	82.4	66.0	50.4	35.7
215	98.4	80.8	64.6	49.3	34.8
220	97.9	79.2	63.2	48.1	33.9
225	97.4	77.5	61.9	47.0	32.9
230	95.4	75.9	60.5	45.8	32.0
235	93.5	74.3	59.1	44.7	31.1
240	91.5	72.7	57.8	43.6	30.2
245	89.7	71.2	56.4	42.5	29.4
250	87.8	69.6	55.1	41.5	28.5
255	86.0	68.1	53.9	40.4	27.7
260	84.1	66.6	52.6	39.4	26.9
265	82.3	65.1	51.4	38.5	26.2
270	80.6	63.7	50.2	37.5	25.4
275	78.9	62.3	49.1	36.6	24.7
280	77.2	60.9	48.0	35.7	24.0
285	75.6	59.7	46.9	34.9	23.3
290	74.1	58.4	46.0	34.1	22.7
295	72.6	57.2	45.0	33.3	22.1
300	71.1	56.1	44.0	32.6	21.5
305	69.8	55.0	43.2	31.9	21.0
310	68.5	54.0	42.4	31.3	20.5
315	67.4	53.2	41.7	30.7	20.1
320	66.3	52.3	41.0	30.2	19.7
325	65.3	51.6	40.5	29.8	19.3
330	64.5	51.0	40.0	29.4	19.0
335	61.3	50.5	39.6	29.1	18.8
340	56.5	50.2	39.4	28.9	18.6
345	50.9	50.1	39.3	28.8	18.5
350	42.7	47.7	39.3	28.8	18.5
355	31.0	41.1	39.3	28.8	18.5
360			39.3	28.8	18.5
365				28.8	18.5

For complete chart, refer to www.cranelibrary.com.

Manitowoc Crane Care

Manitowoc Crane Care is the industry's most advanced service and support program, designed to keep your cranes up and running. Manitowoc's distributor network and customer support personnel are available to support you 24 hours a day, 7 days a week, 365 days a year. There are five key disciplines of Manitowoc Crane Care:

Parts

Genuine Manitowoc replacement parts are accessible through your distributor.

Service and technical support

Assistance with crane selection, lift planning and ground bearing calculations or field service and maintenance.

Technical publications

Operator, parts, service and capacity chart manuals are available in multiple formats in major languages.

Training

A variety of training courses are available online or through Manitowoc training centers.

EnCORE

Rebuild, repair, remanufacture or exchange your current crane through our local network, for a fraction of the cost of a new crane.

www.manitowoccranecare.com

CraneSTAR

CraneSTAR is an exclusive and innovative crane asset management system that helps improve your profitability and reduce costs by remotely monitoring critical crane data. Visit www.cranestar.com for more information.

Regional headquarters

Manitowoc - Americas

Manitowoc, Wisconsin, USA

Tel: +1 920 684 6621

Fax: +1 920 683 6278

Shady Grove, Pennsylvania, USA

Tel: +1 717 597 8121

Fax: +1 717 597 4062

Manitowoc - Europe, Middle East & Africa

Ecully, France

Tel: +33 (0)4 72 18 20 20

Fax: +33 (0)4 72 18 20 00

Manitowoc - Asia Pacific

Shanghai, China

Tel: +86 21 6457 0066

Fax: +86 21 6457 4955

Regional offices

Americas

Brazil

Alphaville

Mexico

Monterrey

Chile

Santiago

Europe, Middle East & Africa

Algeria

Hydra

Czech Republic

Netvorice

France

Baudemont

Cergy

Decines

Germany

Langenfeld

Hungary

Budapest

Italy

Parabiago

Netherlands

Breda

Poland

Warsaw

Portugal

Baltar

Lisbon

Russia

Moscow

U.A.E.

Dubai

U.K.

Buckingham

Asia - Pacific

Australia

Brisbane

Melbourne

Sydney

China

Beijing

Singapore

Xi'an

Korea

Seoul

India

Pune

Philippines

Makati City

Factories

Brazil

Alphaville

China

Zhangjiagang

France

Charlieu

La Clayette

Moulins

Germany

Wilhelmshaven

India

Calcutta

Pune

Italy

Niella Tanaro

Portugal

Baltar

Fânzeres

Slovakia

Saris

USA

Manitowoc

Port Washington

Shady Grove

This document is non-contractual. Constant improvement and engineering progress make it necessary that we reserve the right to make specification, equipment, and price changes without notice. Illustrations shown may include optional equipment and accessories and may not include all standard equipment.