

# MB-C50 S2

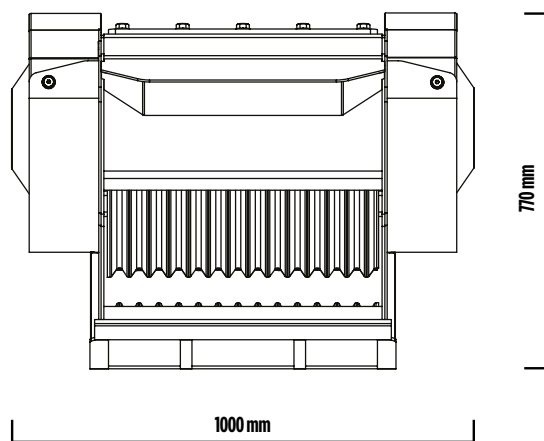

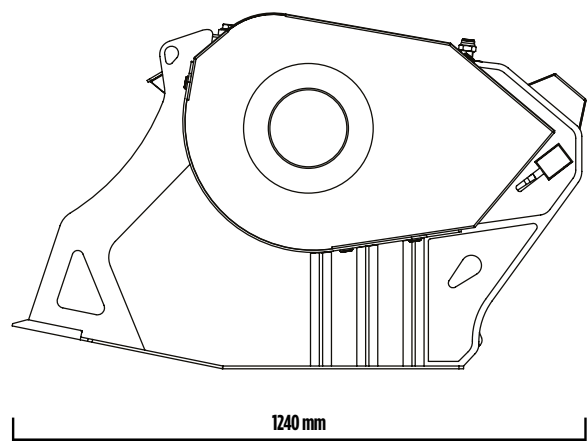

## MB-C50 S2

The MB-C50 crusher bucket is the smallest in the MB range. Agile in very tight spaces and efficient on small-scale sites, it guarantees high performance and excellent results. Thanks to its reduced weight and size, this small MB crusher bucket allows rapid movement in restricted spaces, with the consequential reduction of transportation costs.



## ACCESSORIES

- RECOMMENDED SPARE PARTS KIT
- FIX COUPLER
- QUICK FEMALE COUPLER
- HOUR METER
- DUST SUPPRESSION KIT
- 24 MONTHS WARRANTY

## AREAS OF APPLICATION

- RECYCLING
- URBAN JOB SITES
- ROAD WORKS
- MAINTENANCE OF AGRICULTURAL AND GREEN SPACES
- WATER MAIN REPAIRS
- SMALL-SCALE DEMOLITION
- EXCAVATION

## SPECIFICATIONS

EQUIPMENT	LOAD CAPACITY	OPENING DIMENSIONS	OUTPUT SETTING	DIMENSIONS
 ≥ 4 Ton	0,15 m <sup>3</sup>	L 540 H 250 mm	≥ 15 ≤ 60 mm	1240 x 1000 H 770 mm
OIL FLOW	PRESSURE	COUNTER PRESSURE	WEIGHT	MAXIMUM PRODUCTION
90 l/min.	200 bar	10 bar	0,75 Ton	10 m <sup>3</sup> /h