

## Outline Dimensions

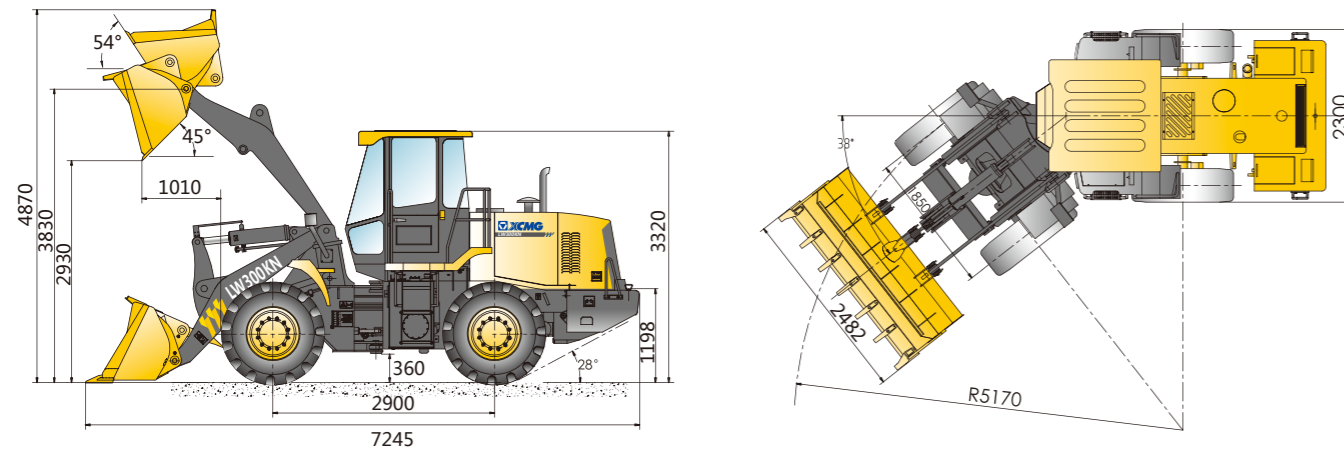

## Main Specifications

Description	Specification	Unit	
Rated operating load	3000	kg	
Bucket capacity	1.5~2.5	m <sup>3</sup>	
Machine weight	10900±200	kg	
Dump clearance at maximum lift	2770~3260	mm	
Reach at maximum lift	1010~1210	mm	
Wheel base	2900	mm	
Tread	1850	mm	
Height of hinge at maximum lift height	3830	mm	
Working height(fully lifted)	4870	mm	
Max.breakout force	130	kN	
Max.horse power	95	kN	
Hydraulic cycle time-raise	5.4	s	
Total hydraulic cycle time	9.3	s	
Min. turning radius over tyres	5170	mm	
Articulation angle	38±1	°	
Gradeability	28	°	
Tyre size	17.5-25-12PR		
Overall machine dimension L×W×H	7245×2482×3320	mm	
Model	WP6G125E201		
Emission standards	Emission 2		
Rated Power/Speed	92/2000	kW/rpm	
Fuel Tank	170	L	
Hydraulic Tank	175	L	
Travel speed	I -gear(F/R)	12/16	km/h
	II-gear(F/R)	38/-	km/h

Structure and specification are subject to change without notice. In case there is any difference between the description of the machine and the substantial machine, the substantial machine should govern.



**XCMG Construction Machinery Co., Ltd.**

Address: NO.99 North Kunpeng Road, Xuzhou Economic Development Zone, Jiangsu, China 221004  
Tel: +86-51687560288 FAX: +86-51683111363 E-mail: sales@xcmg.com Website: http://www.xcmg.com

20170330

# LW300KN WHEEL LOADER

Dedicated to serve high-end heavy-duty applications



### Description Specification

Rated bucket capacity	1.8m <sup>3</sup>
Rated loading capacity	3000kg
Rated power	92kW
Gross weight	10900kg
Dumping height	2930mm
Maximum breakout force	130kN





## Product Overview

- As an outstanding representative of the industry's super-heavy-duty models, LW300KN boasts remarkable advantages in terms of "High energy-conservation, efficiency, reliability, and comfort" compared with industry's like products and is extensively applicable for earth-moving projects, aggregate yards, municipal constructions, and other bulk material transports.

## XCMG's exclusive technologic advantages

■ This product is applied with XCMG's exclusive four leading patents and proprietary technologies.

- XCMG's exclusive energy-conservation technology - The perfect combination between XCMG's patented energy-conservation drive system and low speed energy-conservation engine builds the one and only 3t energy-conservation product in the industry, with the economy superior by >10% to the industry's like products.
- XCMG's patented lubrication technology - The transmission is applied with the XCMG's patented optimal lubrication system design technology to thoroughly improve the industry's difficulties of insufficient and non-uniform transmission lubrications and make the transmission life remarkably leading the industry.
- XCMG's patented high strength frame - With the application of the XCMG's exclusive high strength single plate beam skeleton structure, the "load-carrying material ratio" is remarkably leading the industry products.
- XCMG's unique structure design - The extended wheelbase and the classic 3rd generation loader structure realize higher working capacity, smaller turning radius, and lower wear of rear wheels.



## High firmness and reliability

### ■ XCMG's patented heavy-duty drive system assembly

- The ZL50 planetary transmission is equipped and the imported parts are applied for critical carrying locations. The transmission lubrication system is optimally designed by test system and methods of XCMG's patented technologies so that the lubricating oil volume is distributed on-demand to thoroughly improve the industry's difficulties of insufficient and non-uniform transmission lubrications and make the transmission life remarkably leading the industry.

The drive shaft flanges are of DIN and SAE standard specifications and the distribution diameter of the

- fastening bolts is enlarged to realize super-strong torsion resistance and adapt to severe working conditions.

All load-carrying portions of the drive axle are solid and firm enough to ensure excellent overload resistance

- and meet the needs of diversified high strength and high load operations.



ZL50 transmission with patented technologies



Proved XCMG exclusive drive axle

### ■ Box frame structure of super-strong carrying capacity

- The heavy-duty extended wheelbase (2,900mm) structure design is applied. The front frame adopts the XCMG's characteristic thick plate structure and the rear frame adopts the reliable single plate beam structure to reinforce the skeleton and adapt to the severe working conditions.

- With scientific strength analysis, the design of the material and structure is optimized and the "load-carrying material ratio" is remarkably leading the industry products to achieve higher reliability.



### ■ Comprehensive optimized working device

- The thickened boom plates, the rectangular tube arm support beams, and the enlarged cross section and thickened beam plates remarkably improve the adaptability to severe working conditions.

- The bucket is thoroughly made of high strength steel plates to improve the wear resistance and impact resistance by more than 30% and prolong the service life.



## High energy-conservation and efficiency

### ■ As the sole low speed engine energy-conservation product among the industry's 3t loaders, it's leading the industry's energy-conservation trend.

- With the scientific matching and system optimization to play the machine performance to the maximum degree, the operating economy of the XCMG LW300KN is superior by >10% to the industry like products.
- The high capacity torque converter of patented technologies and the in-depth optimized box axle system realize the best matching and remarkably improve the fuel utilization efficiency.
- The low-speed energy-conservation engine equipped achieves outstanding fuel-saving performance while improving the power performance.
- With the application of the double-pump confluence and steering priority equivalent unloading technologies, the hydraulic system increases the machine traction under composite working condition, remarkably reduces the energy consumption, and improves the working efficiency.

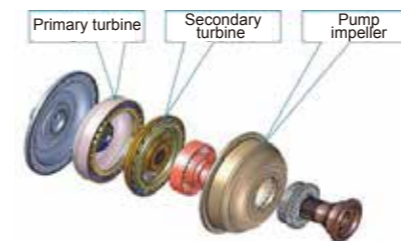

The high capacity torque converter with optimized turbine set grille structure improves the double-pump confluence system to maximize the transmission efficiency and minimize the energy consumption. In addition, the reduced thermal balance temperature of the hydraulic oil effectively improves the reliability of the related parts.



The double-pump confluence system minimizes the energy consumption.



