

Material Handling Machines

LH 30 Industry

Litronic®

LH 35 Industry

Litronic®



Operating Weight
26,500 – 31,900 kg

Engine
140 kW / 190 HP
Stage IV
Stage IIIA

LIEBHERR

Performance

Power plus speed –
Redefined performance

Economy

Good investment –
Savings for long-term

LH 30 M Industry Litronic

Operating Weight
26,500 – 29,100 kg*

Engine

140 kW/190 HP
Stage IV
Stage IIIA

LH 35 M Industry Litronic

Operating Weight
30,700 – 31,900 kg*

Engine

140 kW/190 HP
Stage IV
Stage IIIA

LH 30 C Industry Litronic

Operating Weight
27,100 – 30,200 kg*

Engine

140 kW/190 HP
Stage IV
Stage IIIA

* Without working tool



Reliability

Durability and sustainability –
Quality down to the last detail

Comfort

Perfection at a glance –
When technology is comfortable

Maintainability

Efficiency bonus –
Even with maintenance and service



Performance



Power plus speed – Redefined performance

Liebherr has been designing and manufacturing successful machines for material handling for over 50 years. The new generation of Liebherr handlers, the LH 30 and LH 35 are high performance yet economical machines specially designed for using in scrap recycling, in timber yards and also for handling of bulk materials.

Maximum Handling Capacity

Increased Engine Output

Engine output has been increased from 129 kW to 140 kW compared to the predecessor models, giving the system more torque for more powerful and faster movement. Furthermore, load peaks are compensated cleverly, meaning maximum torque is available at all times for maximum handling capacity.

High Swing Torque

The separate hydraulic pump in the closed slewing circuit only supplies hydraulic fluid to the swing mechanism. The maximum delivery volume is thus available at any time for turning the uppercarriage for fast and dynamic rotational movements.

Captivating Dynamics

The combination of 140 kW of engine output and an increased pump delivery volume guarantees maximum acceleration and speed of working motions.



Liebherr Diesel Engine Compliant with Stage IV and IIIA

- Powerful, robust and reliable
- Maximum torque even at low speeds to ensure fast movements with low fuel consumption
- Common-Rail injection system for maximum efficiency
- Emissions treatment with Liebherr SCR technology at stage IV

Precision Operation

Intelligent Electronics

The elaborate machine controls guarantee that the hydraulics are optimally configured for the task at hand. Here, the load sensing control ensures that the flow delivered by the pump is optimally distributed when movements overlap. Speed and power are available whenever they are needed.

Sensitive Hydraulics

The optimal harmonisation between the engine and the control valve allows a fast and direct response from the hydraulics to the input command. This is controlled proportionally to enable smooth and gentle movements to be executed when the joystick is moved.

Firm and Stable Positioning

An essential prerequisite for precise working and maximum handling capacity is the firm and stable positioning of the machine. The design of the Liebherr undercarriage optimises the way forces are induced on components and minimised stress. Together with the elaborate support geometry, maximum stability and durability are guaranteed.

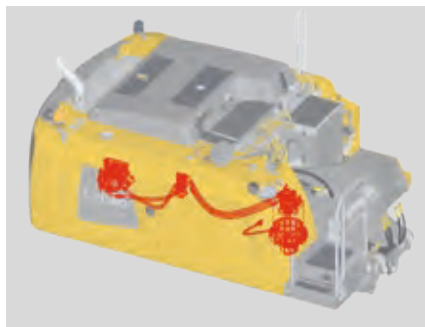

Closed Slewing Circuit

- High torque for maximum acceleration and fast rotary movements
- Integrated speed sensor for controlling and monitoring braking movement for greater safety
- Greater fuel efficiency thanks to intelligent energy management in the closed system



Travel Motor

- Powerful, robust, reliable and quiet
- Better performance even on uphill grades due to electrical swivel angle adjustment for more torque, maximum acceleration and more driving power
- Fuel efficiency at maximum speed due to optimal adjustment of speed and delivery volume

Economy



Good investment – Savings for long-term

Liebherr material handling machines combine high productivity with excellent economy – all as standard. Liebherr manages to achieve this difficult goal through sophisticated engine technology from its own production and improved demand-controlled hydraulics.

Fuel Efficiency

Low Engine Speeds

Compared to the predecessor model, the engine speed has been reduced from 1,800 rpm to 1,700 rpm. The machine's operating point has thus been optimised for outstanding fuel efficiency at maximum handling capacity.

Engine Idling and Engine Shut-down

The standard automatic idling function reduces the engine speed to idle as soon as the operator takes his hand from the joystick so that no hydraulic function is activated. Proximity sensors in the joystick levers restore the original engine speed as soon as the operator's hand is moved towards the lever again. This ensures that the set engine speed is available immediately. The result is a combination of fuel saving and reduced noise levels. Operating costs can be reduced even further with the optional automatic engine shut-down function.

Closed Hydraulic Circuit for the Swing Mechanism

The closed slewing circuit feeds the braking energy back into the system when the uppercarriage is braked. Here, new standards are set in terms of efficiency and economy. Simple yet effective.

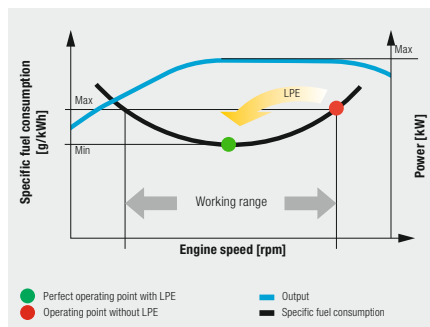

Increased Productivity

Working Tools and Quick Coupling Systems

Liebherr offers a wide selection of working tools for every application to increase the productivity of its material handling machines. In addition the material handlers can be fitted with a Liebherr quick coupling system which increase the productivity of the machine by up to 30%. The matching working tool and quick coupling system combined with the outstanding dynamics of a Liebherr handler ensures highest handling capacity and maximum productivity.

Efficient Management

LiDAT, Liebherr's own data transmission and positioning system, facilitates efficient management, monitoring and control of the entire fleet park in terms of machinery data recording, data analysis, fleet park management and service. All of the important machinery data can be viewed at any time in a web browser. LiDAT offers you comprehensive work deployment documentation, greater availability thanks to shorter downtimes, faster support from the manufacturer, quicker detection of strain/overload and subsequently a longer service life of the machine as well as greater planning efficiency in your company. This service includes 1 year of use without charge as standard for the material handlers LH 30 and LH 35.

Low Fuel Consumption Thanks to Intelligent Machine Control

- Liebherr-Power Efficiency (LPE) optimises the interaction of the drive components in terms of efficiency
- LPE enables machine operation in the area of the lowest specific fuel use for less consumption and greater efficiency with the same performance

Liebherr-Working Tools

- Robust and service-friendly slewing drive, can be turned 360°
- Optimum filling and clamping performance for effective material handling
- Finite element method (FEM) optimised for a perfect relationship between grapple weight, volume and a very long service life

Eco-Mode

- Reducing the engine speed by pressing a button
- Lower fuel consumption with unchanged high performance
- Economical and environmentally friendly working guaranteed
- Ideal for light to medium operations

Reliability



Durability and sustainability – Quality down to the last detail

Every day Liebherr material handlers show their qualities in a very wide range of industrial applications all over the world. Years of experience, continuous development and the latest technologies provide maximum safety in use. Their robust, compact design and the use of components produced in-house ensure that the material handling machines LH 30 and LH 35 are designed for a long service life.

More Safety

Pipe Fracture Safety Valves

The standard pipe fracture safety valves on the stick and hoist cylinders prevents the attachments from dropping in an unregulated way and ensure maximum safety during every operation.

Working Range Limiters

For operations in which the working range should be limited, the material handling machines can be equipped optional with a working range limitation feature. Hereby all types of dimensions can be set: height, depth, width and proximity. Collisions and resulting component damage can thus be avoided.

Overload Warning Device and Load Torque Limitation

The acoustic and visual overload warning system continuously tells the operator about the current load situation of the machine. Furthermore, load torque limitation automatically regulates the speed of the working hydraulics to allow the maximum load bearing capacity to be approached safely. In the event of an overload, the functions which could cause the machine to topple are disabled. Only movements back to the safe working range are then possible.



QPDM – Quality and Process Data Management

- QPDM allows production data to be logged, documented and evaluated
- Automation of documentation and test specifications
- Ability to handle large quantities with maintain uniform high quality

Dust-intensive Jobs

- Large-dimension radiator with large mesh for optimum cooling performance even in very dusty places
- A new, sealed engine compartment prevent dust penetration
- Reversible fan reduces the rate at which the engine and radiator become clogged and guarantee good machine availability
- Folding air conditioning condenser for quicker and easier cleaning

Attachment

- Components enhanced using FEM for maximum service life even if subjected to heavy lateral stresses during demanding tasks
- Cables routed internally to protect them from damage
- High load capacities with long reaches
- Reaches up to 15 m

High Machine Availability

Quality and Competence

Our experience, understanding of customer needs and the technical implementation of these findings guarantee the success of the product. For decades, Liebherr has been inspirational with its depth of production and system solutions. Key components such as the diesel engine, electronic components, slewing ring, swivelling drive and hydraulic cylinders are developed and produced by Liebherr itself. The great depth of in-house manufacturing guarantees maximum quality and ensures that components are optimally configured to each other.

Robust Design

All steel components are designed and manufactured by Liebherr itself. High-strength steel plates configured for the toughest of requirements result in high torsional stiffness and optimum absorption of forces induced for a longer service life.

Intelligent Self Diagnostics

The clever control electronics permanently monitor the vital functions of the machine to guarantee a high level of machine availability. Components which are critical for safety are designed with redundancy to guarantee maximum reliability.

Comfort



Perfection at a glance – When technology is comfortable

The newly designed operator's work station sets new standards in comfort. The Liebherr deluxe cab is spacious, has an ergonomic design and is very quiet. This ensures that the operator remains intent and fully concentrated throughout the working day and enables him to deliver a constantly high performance.

Deluxe Cab

Ergonomic Design

The modern cab design provides excellent conditions for healthy, concentrated and productive work in maximum comfort. The colour touchscreen display, the controls and operator's seat Comfort are all coordinated to form a perfect ergonomic unit. In addition the ergonomic joysticks allow the machine operation to be both pleasant and precise.

Excellent All-round Vision

The large areas of glass, different versions of cab elevations and the rear and side area monitoring systems provide the operator with an excellent view of his working area and the zone around the machine. This perfect view enhances the operator's safety and ensures that he can handle the machine safely at all times.

Low Noise Levels

The use of viscoelastic mounts, good insulation and low-noise diesel engines from Liebherr minimises noise emissions and vibrations. The noise levels are just 71 dB(A) in the operator's cab and 103 dB(A) outside. This means that the material handlers LH 30 and LH 35 have low noise to preserve people and the environment.



Comfortable Operation

Proportional Control

Precision and fine control of the material handling machine are especially important in applications such as waste separation or scrap recycling. Thanks to the standard proportional control, even such demanding operations can be mastered in style.

Steering and Stabilizer on Joystick

The standard joystick steering gives the operator an additional comfort boost. The steering movement can be conveniently executed using the joystick, eliminating the need to reposition during the work cycle. Abandoning the steering wheel in favour of joystick steering provides additional leg-room and a clear view of the working area. A new standard feature is the control of the outriggers with the joystick for more comfort and an increased productivity of the machine.

Colour Touchscreen Display and Operation Unit

The 7" colour touchscreen display is intuitive in its operation and provides continuous information about all important operating data. The shortcut keys can be individually assigned and are selected quickly and easily with the menu strip.

Safe Access

- Foldable arm console for a safe and comfortable access
- Wide, non-slip steps and ergonomically positioned handles for an easy and safe access
- All access systems are designed to national guidelines and statutory regulations

Operator's Seat Comfort with Adjustable Armrests

- Greater seating comfort due to variable damper hardness, lockable horizontal suspension, pneumatic lumbar support, seat heating and passive seat air conditioning for concentrated working
- Individual adjustment options for armrests, seat cushion depth, seat angle and head restraint for healthful working

Joystick with Proportional Control

- Good functionality with streamlined, ergonomic design
- 4-way mini-joystick enables versatile possibilities of control without having to encompass, for example steering, outriggers or working tools
- Joysticks – each with two buttons and a rocker switch – also increase the number of functions and thanks to the new design maximum reliability is guaranteed

Maintainability



Efficiency bonus – Even with maintenance and service

The Liebherr material handling machines LH 30 and LH 35 are powerful, robust, precise and efficient. They also feature integral maintenance benefits as a result of their service-based machine design. The maintenance work for the Liebherr material handlers can be carried out quickly, easily and safely. This minimises the material handling machine's maintenance costs and down times.

Elaborate Maintenance Concept

Service-based Machine Design

The service-based machine design guarantees short servicing times, thus minimising maintenance costs due to the time it saves. All the maintenance points are easily accessible from the ground and easy to reach due to the large, wide-opening service doors. The enhanced service concept places the maintenance points close to each other and reduces their number to a minimum. This means that service work can be completed even more quickly and efficiently.

Integral Maintenance Benefits

Completing maintenance work helps keep the machine fully functional. Maintenance work does, however, mean machine down times which must be minimised. With change intervals of up to 2,000 hours for engine oil and up to 8,000 hours for hydraulic oil Liebherr reduce the amount of maintenance significantly and increase the productivity of the material handlers. In addition, central lubrication systems assist to optimise the daily amount of maintenance.

Your Competent Service Partner

Remanufacturing

The Liebherr remanufacturing program offers cost-effective reconditioning of components to the highest quality standards. Various reconditioning levels are available: Replacement components, general overhaul or repair. The customer receives components with original part quality at a reduced cost.

Competent Advice and Service

Competent advice is given at Liebherr. Experienced specialists provide decision guidance for your specific requirements: application-oriented sales support, service agreements, value-priced repair alternatives, original parts management, as well as remote data transmission for machine planning and fleet management.



Lubrication as it Works

- Fully automatic central lubrication system for uppercarriage and attachment
- Can be extended as an option to the connection link, quick coupler and working tool
- Fully automatic central lubrication system for the undercarriage available as an option
- Lubricates without interrupting work to ensure better productivity and a long component service life

Excellent Service Access

- Large, wide-opening service doors
- Engine oil, fuel, air and cab air filters are easily and safely accessible from the ground
- The oil level in the hydraulic tank can be checked from the cab
- Short service times for more productivity

Rapid Spare Parts Service

- 24-hour delivery: Spare parts service is available for our dealers around the clock
- Electronic spare parts catalogue: Fast and reliable selection and ordering via the Liebherr online portal
- With online tracking, the current processing status of your order can be viewed at any time

Material Handling Machines Overview

Uppercarriage

- Greater fuel efficiency thanks to the latest engine technology with intelligent machine control
- 140 kW engine output and greater pump flow for fast work cycles, convincing dynamics and maximum handling performance
- Reversible fan and large-meshed cooler as a reliable, sealed unit for high machine availability
- Reduction in operating costs thanks to built-in maintenance advantages and optimum service accessibility

Undercarriage

- Optimised hydraulics with closed slewing mechanism circuit for greater fuel efficiency and faster work cycles
- Maximum acceleration and higher drawbar pull thanks to a new travel motor for greater travelling performance
- Load-holding valves fitted as standard on all support cylinders for maximum stability in every application
- Fewer downtimes thanks to maintenance-free support cylinders





Operator's Cab

- Joystick steering without steering column as standard for convenient operation, greater legroom and clear view of the working area
- Less strain on the operator, workers and reduced environmental pollution due to lower noise emissions
- Optimum visibility thanks to large glass surfaces and standard rear and side area monitoring with camera
- Proportional control as standard with 4-way minijoystick for greater precision, high-precision control and functions

Attachment

- High load capacities and long reaches thanks to optimised kinematic properties and robust construction for greater handling performance
- Ingenious routing of hydraulic hoses optimises the oil flow and minimises power losses for maximum energy efficiency
- Pipe fracture safety valves on hoist and stick cylinders and retract stick shut-off for maximum safety during every application
- Quick coupling systems and working tools made by Liebherr for maximum machine capacity utilisation and greater handling performance

The Perfect Solution for Every Application

Working tools

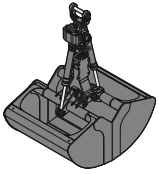

Shells for loose material

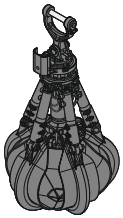

Multi-tine grab



Wood grab

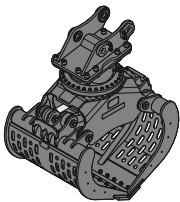

Sorting grab

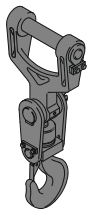

Load hook

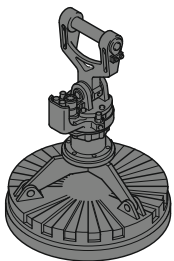

Magnet devices

Sticks

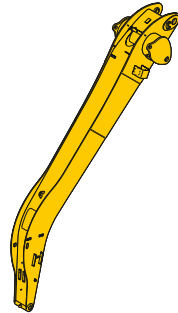

Angled stick

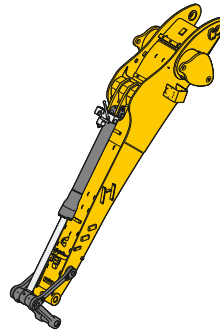

Stick with tipping kinematics

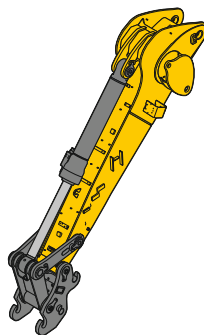

Stick for scrap shear

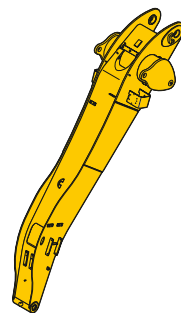

Flat angled stick

Booms

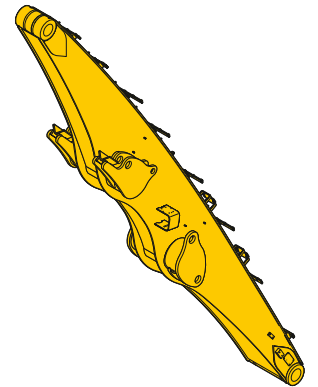

Straight boom

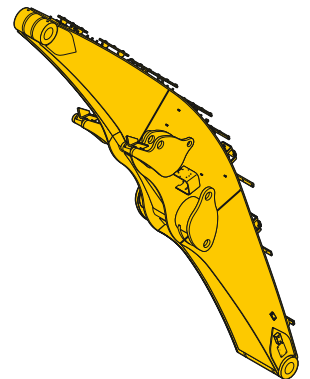

Angled boom

Cab Elevations

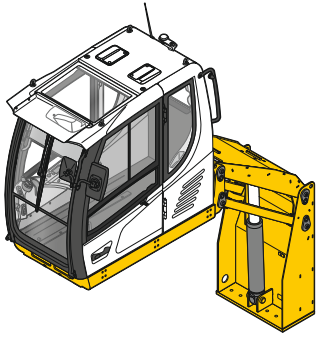

Hydraulic cab elevation

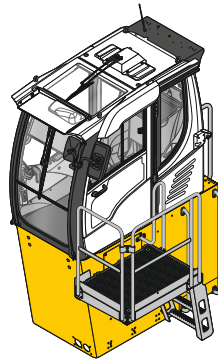

Rigid cab elevation

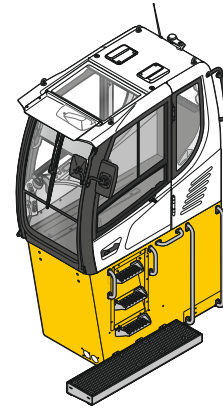

Uppercarriage

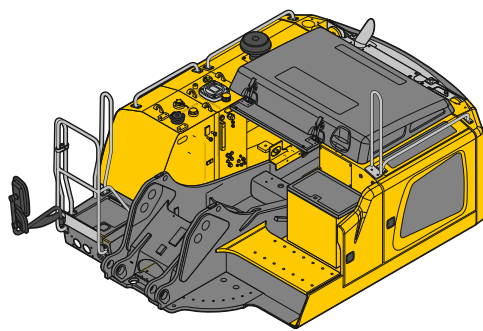

Undercarriage

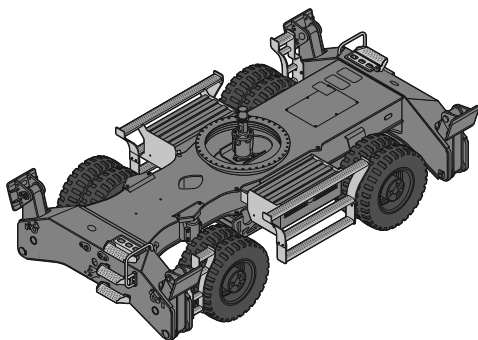

Mobile

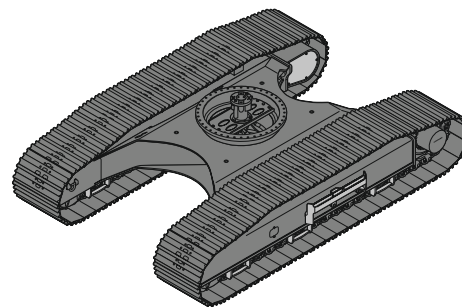

Crawler

Experience the Progress

The invention of the mobile tower crane in 1949 also marked the birth of the Liebherr company. During its first decade the small construction company developed into an established manufacturer of construction machines and other technically advanced products. The R 353 and its first industrial attachment were launched in 1951 to lay the foundations for the production of today's material handling machines. The A 911

mobile material handling machine a few years later enabled the company to make the breakthrough into material handling. Over the years the machines have been developed continually and today they are designed uncompromisingly for the industrial use.

1949

First tower crane TK10



1968

Breakthrough with the A 911 mobile material handler



1974

Silenced material handling machine



R 353 with the first industrial attachment

1961



Production plant in Kirchdorf

1970



First hydraulic cab elevation

1983

Liebherr has now been developing and manufacturing material handling machines for a very wide range of applications in the scrap, port and timber handling sectors and for the waste and recycling industry for over 50 years. In the development of its machines, Liebherr chooses quality, durability and reliability from the very outset, together with performance and economy. Years of experience in design and construction are not only

reflected in the end product but also in the components which are developed, designed and manufactured by Liebherr itself. This multiple sector expertise is used in product design from the early phase of the development process and thus allows high level technical innovations to be made.

2007

Opening of the assembly building for material handling machines



2011

Launch of the lightweight stick



2013

Launch of the new LH series

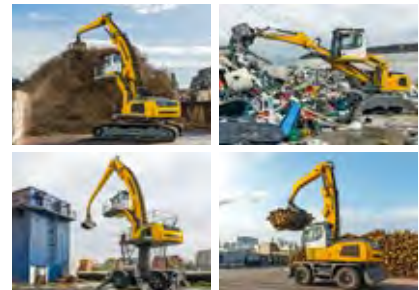

Awarded the Bauma Design Prize for the LH 120

2010



Awarded the Bauma Innovation Prize for the ERC cylinder



Awarded the IF Award for the material handling machine LH 60

2014

Technical Data



Diesel Engine

Rating per ISO 9249	140 kW (190 HP) at 1,700 RPM
Model	Liebherr D934
Type	4 cylinder in-line
Bore/Stroke	122/150 mm
Displacement	7.0 l
Engine operation	4-stroke diesel Common-Rail turbo-charged and after-cooled reduced emissions
Air cleaner	dry-type air cleaner with pre-cleaner, primary and safety elements
Engine idling	sensor controlled
Electrical system	
Voltage	24 V
Batteries	2 x 135 Ah/12 V
Alternator	three-phase current 28 V/140 A
Stage IV	
Harmful emissions values	in accordance with 97/68/EG stage IV
Emission control	Liebherr-SCR technology
Fuel tank	330 l
Urea tank	46 l
Stage IIIA	
Harmful emissions values	in accordance with 97/68/EG stage IIIA
Fuel tank	330 l



Cooling System

Diesel engine	water-cooled compact cooling system consisting cooling unit for water, hydraulic oil and charge air with stepless thermostatically controlled fan
----------------------	--



Hydraulic Controls

Power distribution	via control valves with integrated safety valves, simultaneous actuation of chassis and attachment. Swing drive in separate closed circuit
Servo circuit	
Attachment and swing	with hydraulic pilot control and proportional joystick levers
Chassis	
Mobile	electroproportional via foot pedal
Crawler	with hydraulic proportionally functioning foot pedals or adjusted with plugable levers
Additional functions	via switch or electroproportional foot pedals
Proportional control	proportionally acting transmitters on the joysticks for additional hydraulic functions



Hydraulic System

Hydraulic pump	
for attachment and travel drive	2 Liebherr axial piston variable displacement pumps (double construction)
Max. flow	2 x 231 l/min.
Max. pressure	350 bar
for swing drive	reversible axial piston variable displacement pump, closed-loop circuit
Max. flow	140 l/min.
Max. pressure	420 bar
Hydraulic pump regulation and control	Liebherr-Synchron-Comfort-system (LSC) with electronic engine speed sensing regulation, pressure and flow compensation
Hydraulic tank	175 l
Hydraulic system	430 l
Hydraulic oil filter	1 main return filter with integrated partial micro filtration (5 µm)
MODE selection	adjustment of engine and hydraulic performance via a mode pre-selector to match application, e.g. for especially economical and environmentally friendly operation or for maximum material handling and heavy-duty jobs
S (Sensitive)	mode for precision work and lifting through very sensitive movements
E (Eco)	mode for especially economical and environmentally friendly operation
P (Power)	mode for high performance with low fuel consumption
P+ (Power-Plus)	mode for highest performance and for very heavy duty applications, suitable for continuous operation
Engine speed and performance setting	stepless alignment of engine output and hydraulic power via engine speed
Option	Tool Control: 20 preadjustable pump flows and pressures for add on tools



Swing Drive

Drive	Liebherr axial piston motor in a closed system, Liebherr planetary reduction gear
Swing ring	Liebherr, sealed race ball bearing swing ring, internal teeth
Swing speed	0 – 9,5 RPM stepless
Swing torque	76 kNm
Holding brake	wet multi-disc (spring applied, pressure released)
Operation holding brake (Option)	slewing gear brake Comfort



Operator's Cab

Cab	TOPS safety cab structure (tip-over protection) with individual windscreens or featuring a slide-in subpart under the ceiling, work headlights integrated in the ceiling, a door with a sliding window (can be opened on both sides), large stowing and depositing possibilities, shock-absorbing suspension, sounddamping insulating, tinted laminated safety glass, separate shades for the sunroof window and windscreen
Operator's seat Comfort	air cushioned operator's seat with 3D-adjustable armrests, headrest, lap belt, seat heater, adjustable seat cushion inclination and length, lockable horizontal suspension, automatic weight adjustment, adjustable suspension stiffness, pneumatic lumbar vertebrae support and passive seat climatisation with active coal
Operator's seat Premium (Option)	in addition to operator's seat comfort: active electronic weight adjustment (automatic re-adjustment), pneumatic low frequency suspension and active seat climatisation with active coal and ventilator
Control system	joysticks with arm consoles and swivel seat, folding left arm console
Operation and displays	large high-resolution operating unit, self-explanatory, colour display with touchscreen, video-compatible, numerous settings, control and monitoring options, e.g. air conditioning control, fuel consumption, machine and tool parameters
Air-conditioning	automatic air-conditioning, recirculated air function, fast de-icing and demisting at the press of a button, air vents can be operated via a menu; recirculated air and fresh air filters can be easily replaced and are accessible from the outside; heating-cooling unit, designed for extreme outside temperatures, sensors for solar radiation, inside and outside temperatures



Attachment

Type	high-strength steel plates at high-stressed points for the toughest requirements. Complex and stable mountings of attachment and cylinders
Hydraulic cylinders	Liebherr cylinders with special seal system as well as shock absorption
Bearings	sealed, low maintenance



Undercarriage

Mobile	
Drive	oversized two speed power shift transmission with additional creeper speed, Liebherr axial piston motor with functional brake valve on both sides
Travel speed	
Joystick steering	0 – 3.5 km/h stepless (creeper speed + transmission stage 1) 0 – 7.0 km/h stepless (transmission stage 1) 0 – 12.0 km/h stepless (creeper speed + transmission stage 2) 0 – 12.0 km/h stepless (transmission stage 2)
Wheel steering (Option)	0 – 3.5 km/h stepless (creeper speed + transmission stage 1) 0 – 7.0 km/h stepless (transmission stage 1) 0 – 13.0 km/h stepless (creeper speed + transmission stage 2) 0 – 20.0 km/h stepless (transmission stage 2)
Driving operation	automotive driving using accelerator pedal, cruise control function: storage of variable accelerator pedal positions
Axles	40 t/60 t drive axles (LH 30 M/LH 35 M); manual or automatic hydraulically controlled front axle oscillation lock
Option	four wheel steering (LH 35 M)
Service brake	two circuit travel brake system with accumulator; wet and backlash-free disc brake
Holding brake	wet multi-disc (spring applied, pressure released)
Stabilization	4 point outriggers
Option	dozer blade, at the front, for 4 point outriggers
Crawler	
Versions	LC, EW
Drive	Liebherr compact planetary reduction gear with Liebherr axial piston motor per side of undercarriage
Travel speed	0 – 3.0 km/h stepless (creeper speed) LC-Undercarriage 0 – 3.0 km/h stepless (creeper speed) EW-Undercarriage 0 – 4.7 km/h stepless LC-Undercarriage 0 – 4.1 km/h stepless EW-Undercarriage
Brake	functional brake valves on both sides
Holding brake	wet multi-disc (spring applied, pressure released)
Track pads	triple grouser



Complete Machine

Lubrication	Liebherr central lubrication system for upper-carriage and attachment, automatically
Mobile (Option)	Liebherr central lubrication system for under-carriage, automatically
Steps system	safe and durable access system with anti-slip steps main components hot-galvanised
Noise emission	
ISO 6396	L_{pA} (inside cab) = 71 dB(A)
2000/14/EC	L_{WA} (surround noise) = 103 dB(A)

LH 30 M – Dimensions

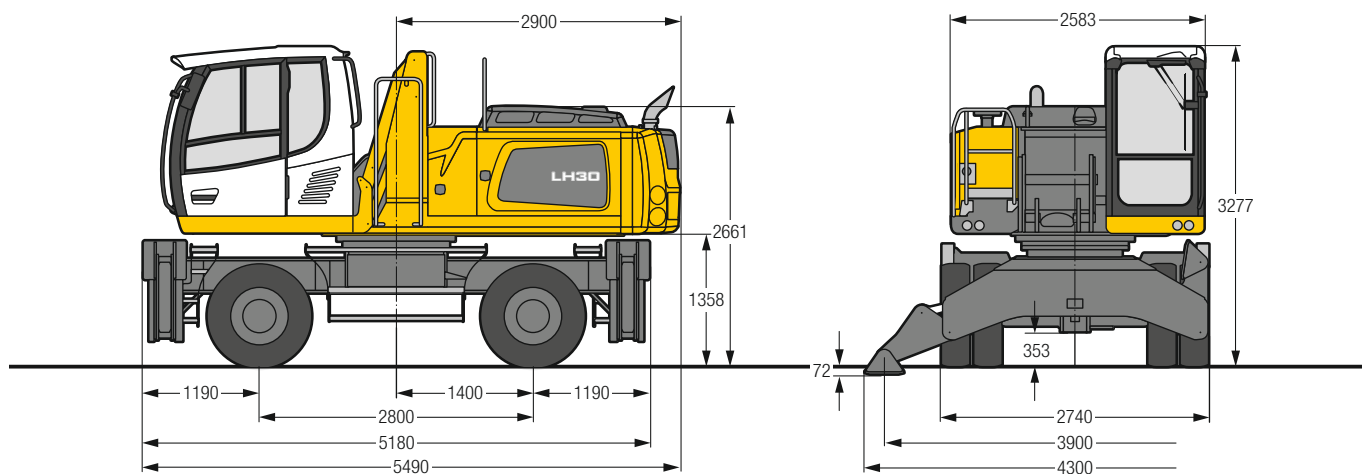

LH 30 M – Choice of Cab Elevation

Cab Elevation LFC (Rigid Elevation)

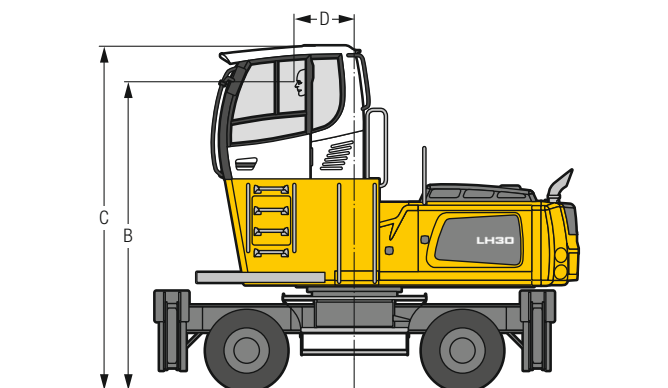

Increase type	LFC 120
Height	1,200 mm
B	4,013 mm
C	4,477 mm
D	788 mm

A rigid cab elevation has a fixed eye level height. For a lower transport height, the shell of the cab can be removed and replaced by a transport device. The dimension C is in this machine design for all rigid cab elevations 3,581 mm.

Cab Elevation LHC (Hydraulic Elevation)

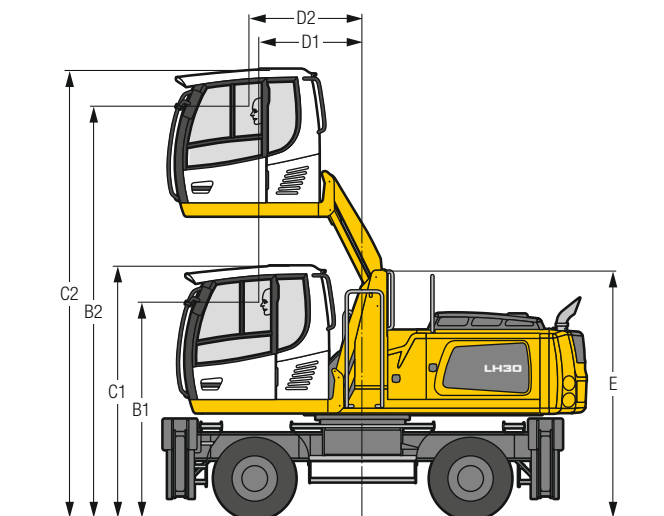

Increase type	LHC 255
B1	2,813 mm
B2	5,360 mm
C1	3,277 mm
C2	5,824 mm
D1	1,343 mm
D2	1,468 mm
E	3,218 mm

The hydraulically adjustable cab allows the driver, that he can choose his field of view freely and at any time within the stroke.

Tyres 10.00-20

LH 35 M – Dimensions

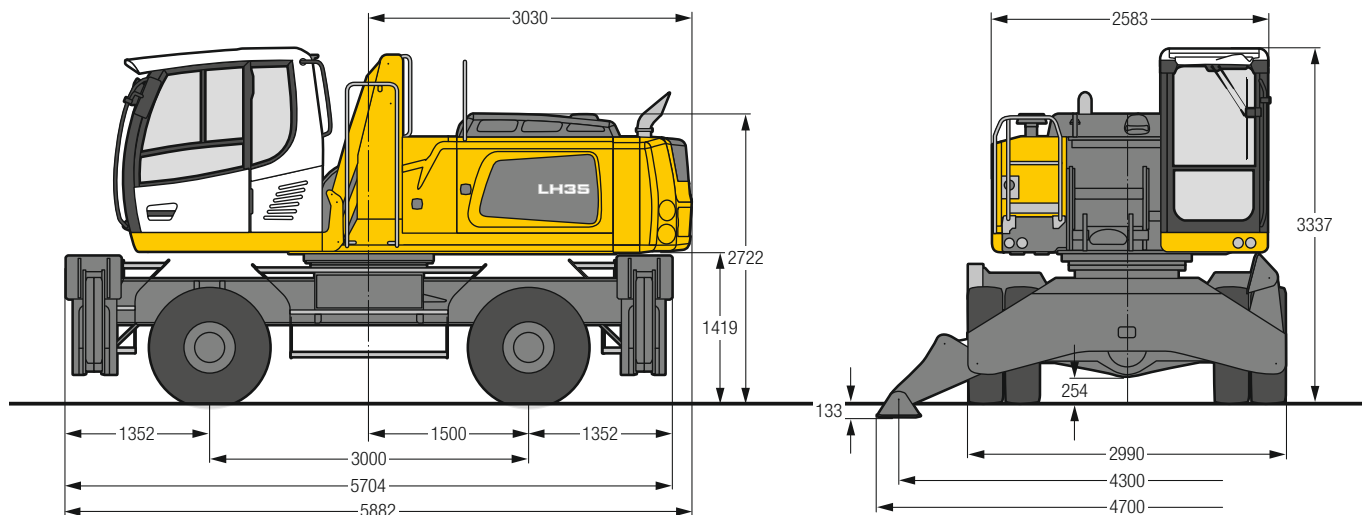

LH 35 M – Choice of Cab Elevation

Cab Elevation LFC (Rigid Elevation)

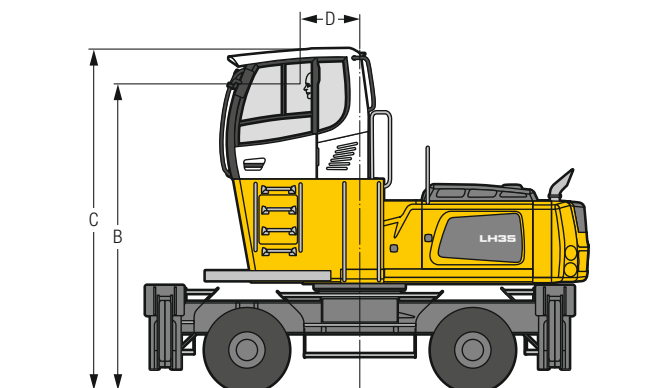

Increase type	LFC 120
Height	1,200 mm
B	4,070 mm
C	4,535 mm
D	788 mm

A rigid cab elevation has a fixed eye level height. For a lower transport height, the shell of the cab can be removed and replaced by a transport device. The dimension C is in this machine design for all rigid cab elevations 3,639 mm.

Cab Elevation LHC (Hydraulic Elevation)

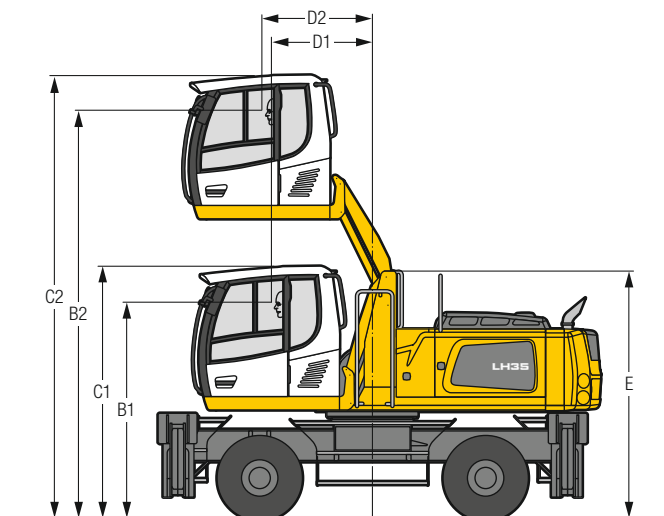

Increase type	LHC 255
B1	2,874 mm
B2	5,421 mm
C1	3,338 mm
C2	5,885 mm
D1	1,343 mm
D2	1,468 mm
E	3,279 mm

The hydraulically adjustable cab allows the driver, that he can choose his field of view freely and at any time within the stroke.

Tyres 12.00-20

LH 30 C LC – Dimensions

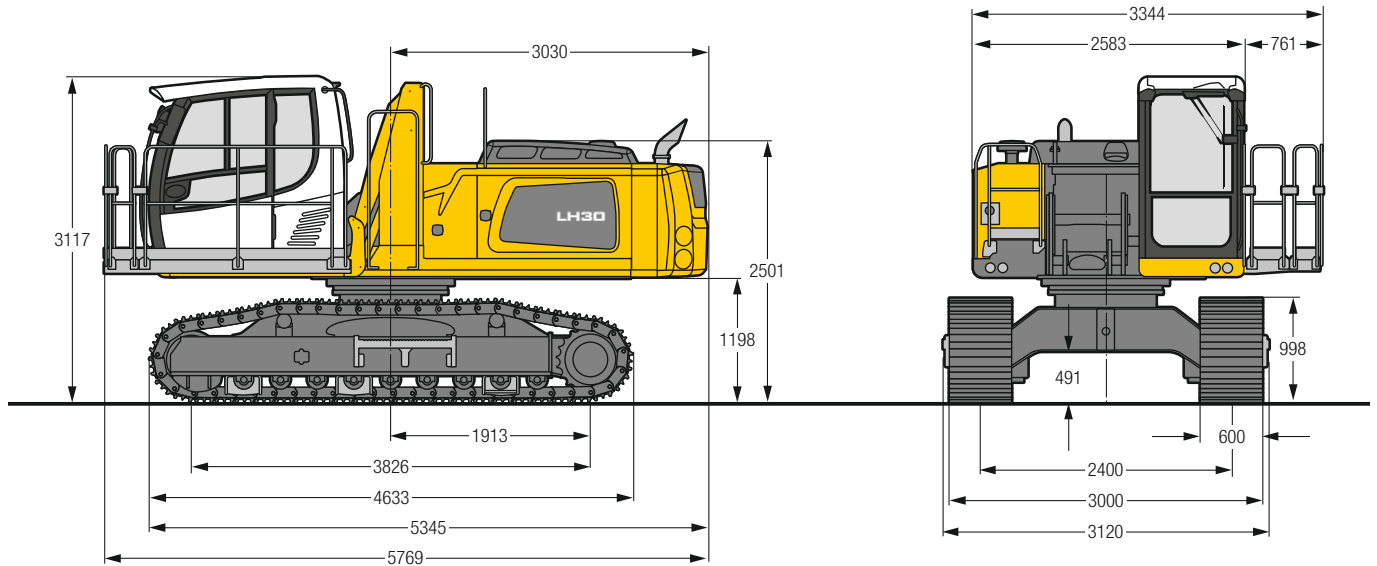

LH 30 C LC – Choice of Cab Elevation

Cab Elevation LFC (Rigid Elevation)

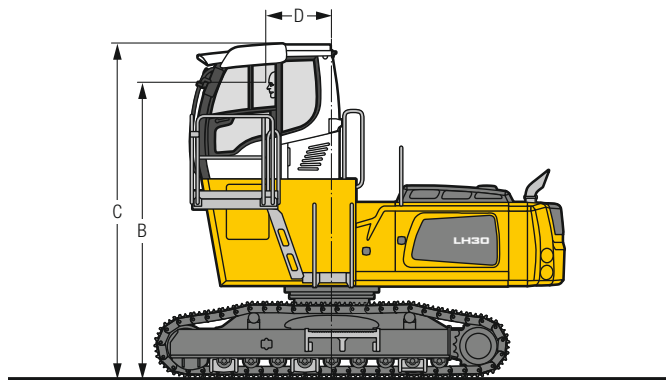

Increase type	LFC 120
Height	1,200 mm
B	3,853 mm
C	4,317 mm
D	788 mm

A rigid cab elevation has a fixed eye level height. For a lower transport height, the shell of the cab can be removed and replaced by a transport device. The dimension C is in this machine design for all rigid cab elevations 3,421 mm.

Cab Elevation LHC (Hydraulic Elevation)

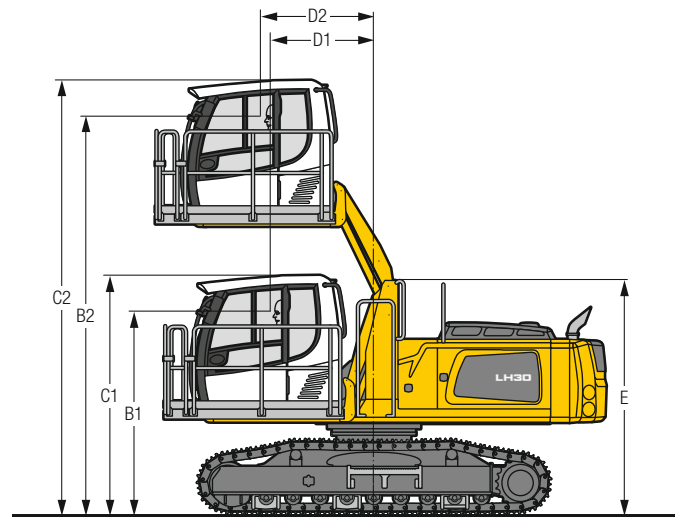

Increase type	LHC 255
B1	2,653 mm
B2	5,200 mm
C1	3,117 mm
C2	5,664 mm
D1	1,343 mm
D2	1,469 mm
E	3,058 mm

The hydraulically adjustable cab allows the driver, that he can choose his field of view freely and at any time within the stroke.

LH 30 C EW – Dimensions

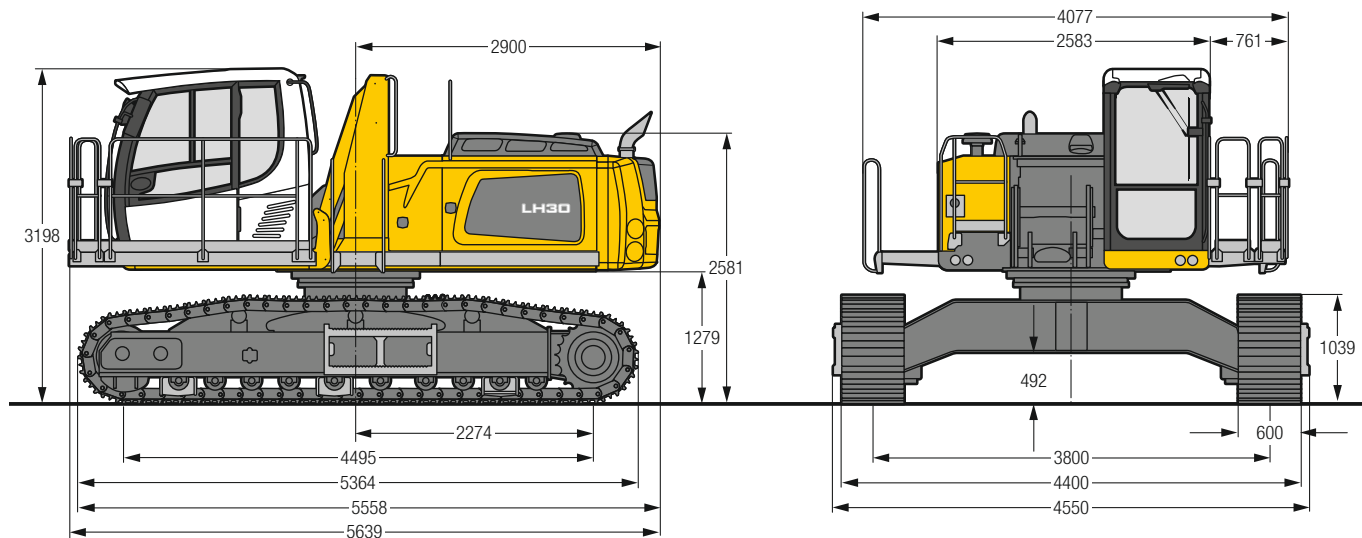

LH 30 C EW – Choice of Cab Elevation

Cab Elevation LFC (Rigid Elevation)

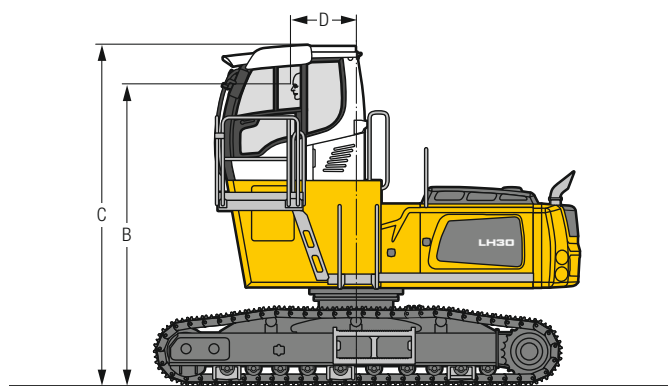

Increase type	LFC 120
Height	1,200 mm
B	3,934 mm
C	4,398 mm
D	788 mm

A rigid cab elevation has a fixed eye level height. For a lower transport height, the shell of the cab can be removed and replaced by a transport device. The dimension C is in this machine design for all rigid cab elevations 3,502 mm.

Cab Elevation LHC (Hydraulic Elevation)

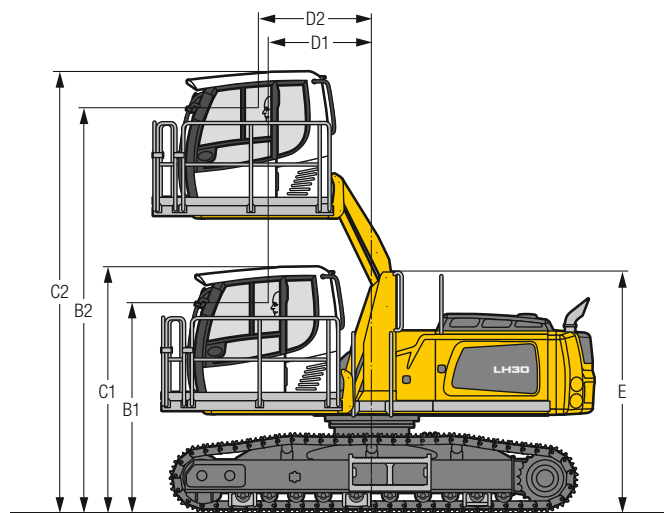

Increase type	LHC 255
B1	2,733 mm
B2	5,280 mm
C1	3,198 mm
C2	5,745 mm
D1	1,343 mm
D2	1,469 mm
E	3,139 mm

The hydraulically adjustable cab allows the driver, that he can choose his field of view freely and at any time within the stroke.

LH 30 M – Attachment AF11

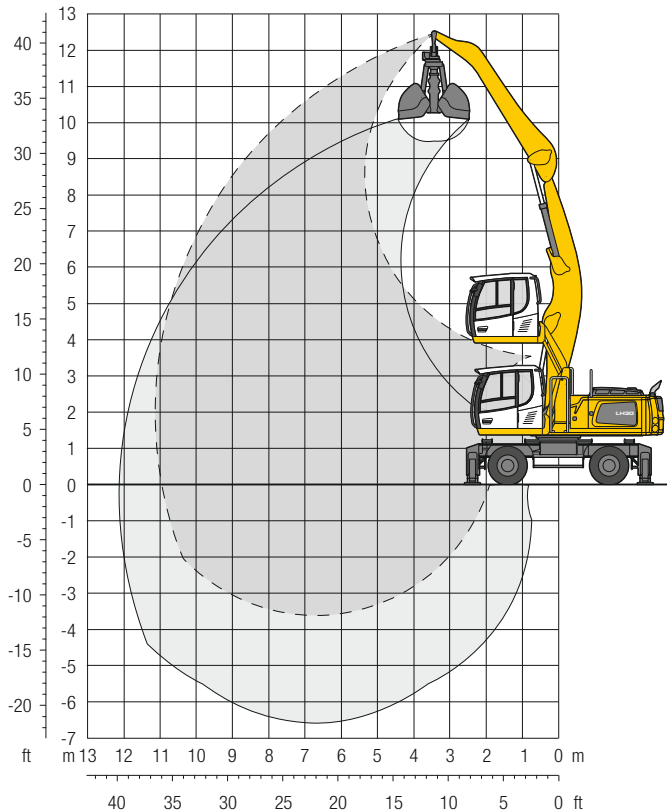

Operating Weight

The operating weight includes the basic machine with 4 point outriggers, hydr. cab elevation, 8 solid tyres plus intermediate rings, angled boom 6.50 m, flat angled stick 5.00 m and grab GM 20C/1.50 m³ shells for loose material.

Weight 28,700 kg

Dimensions

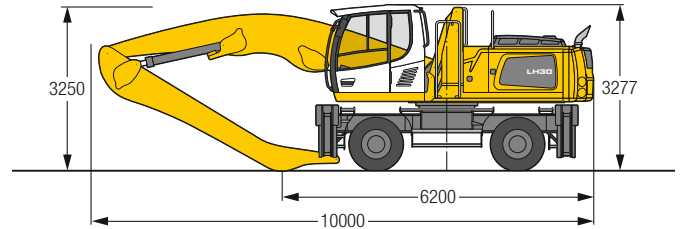

m	3.0 m		4.5 m		6.0 m		7.5 m		9.0 m		10.5 m		12.0 m		13.5 m		15.0 m		m		
	Stabilizers raised	4 pt. outriggers down	Stabilizers raised	4 pt. outriggers down	Stabilizers raised	4 pt. outriggers down	Stabilizers raised	4 pt. outriggers down	Stabilizers raised	4 pt. outriggers down	Stabilizers raised	4 pt. outriggers down	Stabilizers raised	4 pt. outriggers down	Stabilizers raised	4 pt. outriggers down	Stabilizers raised	4 pt. outriggers down	Stabilizers raised	4 pt. outriggers down	
12.0			6.4*	6.4*															6.1*	6.1*	4.7
10.5					6.1	6.8*													6.1*	6.1*	7.1
9.0					6.8*	6.8*													4.5	4.9*	8.6
7.5					6.2	7.2*	4.3	5.6											4.9*	4.9*	9.7
6.0					7.2*	7.2*	6.5*	6.5*											3.3	4.4	10.4
4.5					6.2	7.3*	4.3	5.6	3.1	4.1									4.5*	4.5*	10.9
3.0					7.3*	7.3*	6.5*	6.5*	5.9*	5.9*									2.7	3.6	11.1
1.5					6.0	7.6*	4.2	5.5	3.0	4.1									4.3*	4.3*	11.1
0					7.6*	7.6*	6.7*	6.7*	6.0*	6.0*									2.3	3.1	11.0
-1.5					8.8	10.2*	5.6	7.5	4.0	5.3	2.9	3.9	2.2	3.0					4.2*	4.2*	9.1
-3.0					10.2*	10.2*	8.3*	8.3*	7.0*	7.0*	5.9	6.1*	4.6	5.3*					2.1	2.9	
					14.5	18.1*	7.9	10.9	5.2	7.0	3.7	5.0	2.8	3.8	2.2	3.0			4.2*	4.2*	
					18.1*	18.1*	11.9*	11.9*	9.0*	9.0*	7.4*	7.4*	5.7	6.2*	4.5	5.3*			2.0	2.7	
					5.5*	5.5*	6.9	9.8	4.7	6.5	3.5	4.7	2.6	3.6	2.1	2.9			4.1	4.4*	
					5.5*	5.5*	13.0*	13.0*	9.6*	9.6*	7.3	7.6*	5.6	6.2*	4.4	5.1*			1.9	2.6	
					4.7*	4.7*	6.3	9.2	4.4	6.1	3.2	4.5	2.5	3.5	2.0	2.8			4.1	4.6*	
					4.7*	4.7*	13.1*	13.1*	9.6*	9.6*	7.0	7.5*	5.4	6.1*	4.3	4.8*			1.9	2.7	
					5.6*	5.6*	6.0	8.8	4.1	5.9	3.1	4.4	2.4	3.4	2.0	2.8			4.1	4.4*	
					5.6*	5.6*	11.1*	11.1*	9.0*	9.0*	6.9	7.1*	5.3	5.6*	4.1*	4.1*			4.1	4.4*	
							6.0	8.8	4.1	5.8	3.0	4.3	2.4	3.4					2.0	2.8	
							9.8*	9.8*	7.7*	7.7*	6.1*	6.1*	4.6*	4.6*					4.0*	4.0*	
																			2.4	3.3	
																			4.5*	4.5*	

Height **Can be slewed through 360°** **In longitudinal position of undercarriage** **Max. reach** * Limited by hydr. capacity

The lift capacities on the stick end without attachment are stated in metric tons (t) and are valid on a firm, level supporting surface with blocked oscillating axle. These capacities can be slewed through 360° with the undercarriage in the transverse position. Capacities in the longitudinal position of the undercarriage (+/- 15°) are specified over the steering axle with the stabilizers raised and over the rigid axle with the stabilizers down. Indicated loads based on the ISO 10567 standard and do not exceed 75% of tipping or 87% of hydraulic capacity. The lift capacity of the unit is limited by its stability, the lifting capability of the hydraulic elements, or the maximum permissible lifting capacity of the load hook.

In accordance with the harmonised European Standard EN 474-5, hydraulic excavators used for lifting operations must be equipped with pipe fracture safety valves, an overload warning device, a load hook and a lift capacity chart.

LH 30 M – Attachment GA12

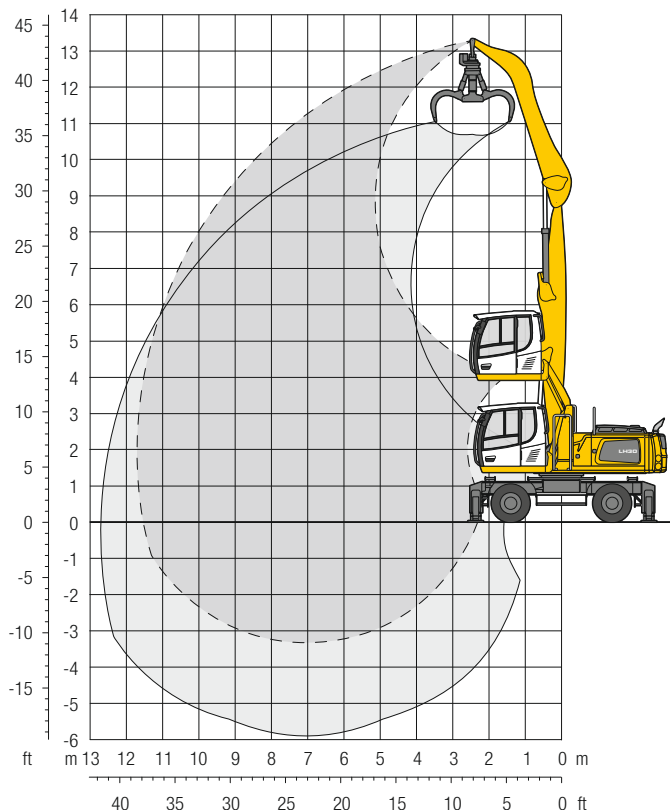

Operating Weight

The operating weight includes the basic machine with 4 point outriggers, hydr. cab elevation, 8 solid tyres plus intermediate rings, straight boom 6.80 m, angled stick 5.00 m and grab GM 65/0.60 m³ semi-closed tines.

Weight 28,400 kg

Dimensions

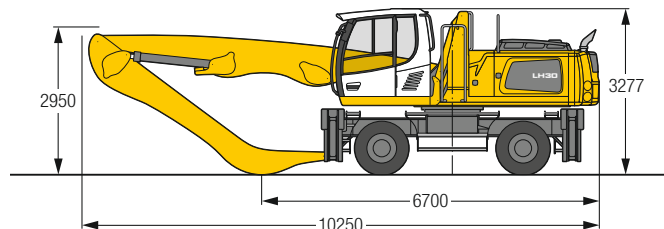

m	Undercarriage	3.0 m		4.5 m		6.0 m		7.5 m		9.0 m		10.5 m		12.0 m		13.5 m		15.0 m		m		
		Stabilizers raised	4 pt. outriggers down	Stabilizers raised	4 pt. outriggers down	Stabilizers raised	4 pt. outriggers down	Stabilizers raised	4 pt. outriggers down	Stabilizers raised	4 pt. outriggers down	Stabilizers raised	4 pt. outriggers down	Stabilizers raised	4 pt. outriggers down	Stabilizers raised	4 pt. outriggers down	Stabilizers raised	4 pt. outriggers down	Stabilizers raised	4 pt. outriggers down	Stabilizers raised
12.0	Stabilizers raised			8.4*	8.4*															5.8	6.1*	5.9
	4 pt. outriggers down			8.4*	8.4*															6.1*	6.1*	
10.5	Stabilizers raised					6.0	7.9	4.1	5.4											3.6	4.8	8.0
	4 pt. outriggers down					8.1*	8.1*	6.2*	6.2*											5.0*	5.0*	
9.0	Stabilizers raised					6.1	7.9*	4.2	5.5	3.0	4.0									2.8	3.7	9.3
	4 pt. outriggers down					7.9*	7.9*	6.9*	6.9*	5.6*	5.6*									4.6*	4.6*	
7.5	Stabilizers raised					6.0	7.9	4.1	5.5	3.0	4.0									2.3	3.1	10.3
	4 pt. outriggers down					8.0*	8.0*	7.0*	7.0*	6.0	6.1*									4.3*	4.3*	
6.0	Stabilizers raised			9.1	10.0*	5.8	7.6	4.0	5.3	3.0	4.0	2.2	3.0							2.0	2.8	11.0
	4 pt. outriggers down			10.0*	10.0*	8.4*	8.4*	7.1*	7.1*	5.9	6.2*	4.6	5.3*							4.2	4.2*	
4.5	Stabilizers raised	10.0*	10.0*	8.4	11.4*	5.4	7.2	3.8	5.1	2.8	3.8	2.2	3.0							1.8	2.6	11.4
	4 pt. outriggers down	10.0*	10.0*	11.4*	11.4*	8.9*	8.9*	7.4*	7.4*	5.8	6.2*	4.5	5.3*							3.9	4.2*	
3.0	Stabilizers raised	13.5	15.7*	7.4	10.4	4.9	6.7	3.6	4.8	2.7	3.7	2.1	2.9							1.7	2.4	11.7
	4 pt. outriggers down	15.7*	15.7*	12.7*	12.7*	9.5*	9.5*	7.4	7.6*	5.6	6.3*	4.4	5.2*							3.8	4.2*	
1.5	Stabilizers raised	2.3*	2.3*	6.6	9.4	4.5	6.3	3.3	4.6	2.6	3.5	2.0	2.8							1.7	2.4	11.7
	4 pt. outriggers down	2.3*	2.3*	13.2*	13.2*	9.7*	9.7*	7.1	7.6*	5.4	6.1*	4.3	5.0*							3.7	3.8*	
0	Stabilizers raised	2.8*	2.8*	6.1	8.8	4.2	5.9	3.1	4.4	2.4	3.4	2.0	2.8							1.7	2.4	11.5
	4 pt. outriggers down	2.8*	2.8*	9.1*	9.1*	9.3*	9.3*	6.9	7.3*	5.3	5.8*	4.3	4.5*							3.4*	3.4*	
-1.5	Stabilizers raised			5.9	8.6	4.0	5.7	3.0	4.3	2.4	3.3	1.9	2.7							1.9	2.6	10.9
	4 pt. outriggers down			8.6*	8.6*	8.2*	8.2*	6.5*	6.5*	5.1*	5.1*	3.7*	3.7*							3.2*	3.2*	
-3.0	Stabilizers raised			4.0	5.7	3.0	4.2													2.4	3.4	8.8
	4 pt. outriggers down			6.5*	6.5*	5.2*	5.2*													4.0*	4.0*	

Height Can be slewed through 360° In longitudinal position of undercarriage Max. reach * Limited by hydr. capacity

The lift capacities on the stick end without attachment are stated in metric tons (t) and are valid on a firm, level supporting surface with blocked oscillating axle. These capacities can be slewed through 360° with the undercarriage in the transverse position. Capacities in the longitudinal position of the undercarriage (+/- 15°) are specified over the steering axle with the stabilizers raised and over the rigid axle with the stabilizers down. Indicated loads based on the ISO 10567 standard and do not exceed 75% of tipping or 87% of hydraulic capacity. The lift capacity of the unit is limited by its stability, the lifting capability of the hydraulic elements, or the maximum permissible lifting capacity of the load hook.

In accordance with the harmonised European Standard EN 474-5, hydraulic excavators used for lifting operations must be equipped with pipe fracture safety valves, an overload warning device, a load hook and a lift capacity chart.

LH 30 M – Attachment GA13

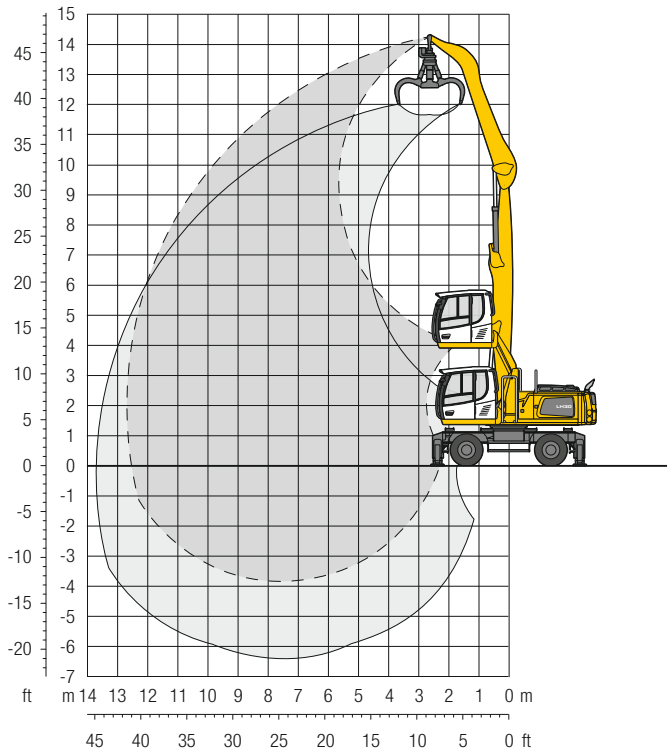

Operating Weight

The operating weight includes the basic machine with 4 point outriggers, hydr. cab elevation, 8 solid tyres plus intermediate rings, straight boom 7.30 m, angled stick 5.50 m and grab GM 65/0.60 m³ semi-closed tines.

Weight 28,700 kg

Dimensions

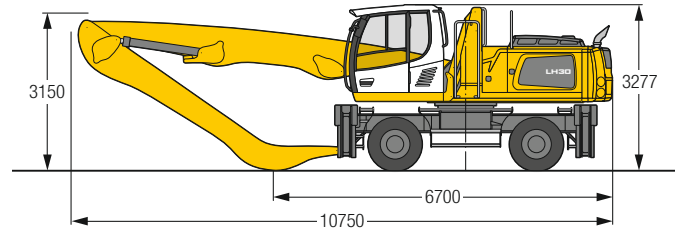

m	Undercarriage	3.0 m		4.5 m		6.0 m		7.5 m		9.0 m		10.5 m		12.0 m		13.5 m		15.0 m		m		
		Stabilizers raised	4 pt. outriggers down	Stabilizers raised	4 pt. outriggers down	Stabilizers raised	4 pt. outriggers down	Stabilizers raised	4 pt. outriggers down	Stabilizers raised	4 pt. outriggers down	Stabilizers raised	4 pt. outriggers down	Stabilizers raised	4 pt. outriggers down	Stabilizers raised	4 pt. outriggers down	Stabilizers raised	4 pt. outriggers down	Stabilizers raised	4 pt. outriggers down	Stabilizers raised
15.0	Stabilizers raised																					
13.5	4 pt. outriggers down																					
13.5	Stabilizers raised			7.3*	7.3*															6.4*	6.4*	5.1
13.5	4 pt. outriggers down			7.3*	7.3*															6.4*	6.4*	5.1
12.0	Stabilizers raised					6.0	7.3*	4.0	5.3											3.8	4.9*	7.7
12.0	4 pt. outriggers down					7.3*	7.3*	5.4*	5.4*											4.9*	4.9*	7.7
10.5	Stabilizers raised					6.2	7.6*	4.2	5.6	3.0	4.0									2.7	3.7	9.4
10.5	4 pt. outriggers down					7.6*	7.6*	6.7*	6.7*	5.2*	5.2*									4.3*	4.3*	9.4
9.0	Stabilizers raised					6.2	7.5*	4.3	5.6	3.1	4.1	2.2	3.0							2.2	3.0	10.6
9.0	4 pt. outriggers down					7.5*	7.5*	6.6*	6.6*	5.8*	5.8*	4.2*	4.2*							4.0*	4.0*	10.6
7.5	Stabilizers raised					6.1	7.7*	4.2	5.5	3.0	4.1	2.3	3.1							1.9	2.6	11.4
7.5	4 pt. outriggers down					7.7*	7.7*	6.6*	6.6*	5.8*	5.8*	4.6	5.1*							3.8*	3.8*	11.4
6.0	Stabilizers raised					5.8	7.7	4.0	5.3	2.9	4.0	2.2	3.0	1.7	2.3					1.6	2.3	12.0
6.0	4 pt. outriggers down					8.1*	8.1*	6.8*	6.8*	5.9	5.9*	4.6	5.1*	3.6	3.9*					3.6	3.8*	12.0
4.5	Stabilizers raised	8.3*	8.3*	8.4	11.2*	5.4	7.2	3.8	5.1	2.8	3.8	2.1	2.9	1.6	2.3					1.5	2.2	12.4
4.5	4 pt. outriggers down	8.3*	8.3*	11.2*	11.2*	8.7*	8.7*	7.1*	7.1*	5.7	6.0*	4.5	5.1*	3.6	4.3*					3.4	3.8*	12.4
3.0	Stabilizers raised	10.4*	10.4*	7.3	10.3	4.8	6.6	3.5	4.8	2.6	3.6	2.0	2.8	1.6	2.3					1.4	2.1	12.7
3.0	4 pt. outriggers down	10.4*	10.4*	12.4*	12.4*	9.2*	9.2*	7.3	7.3*	5.5	6.1*	4.4	5.1*	3.5	4.2*					3.2	3.7*	12.7
1.5	Stabilizers raised	1.6*	1.6*	6.3	9.1	4.3	6.1	3.2	4.4	2.4	3.4	1.9	2.7	1.5	2.2					1.4	2.0	12.7
1.5	4 pt. outriggers down	1.6*	1.6*	12.5*	12.5*	9.4*	9.4*	7.0	7.4*	5.3	6.0*	4.2	5.0*	3.5	3.9*					3.2	3.3*	12.7
0	Stabilizers raised	2.1*	2.1*	5.7	6.9*	3.9	5.7	2.9	4.2	2.3	3.3	1.8	2.6	1.5	2.2					1.4	2.0	12.5
0	4 pt. outriggers down	2.1*	2.1*	6.9*	6.9*	9.1*	9.1*	6.7	7.1*	5.2	5.7*	4.1	4.6*	3.4	3.5*					3.0*	3.0*	12.5
-1.5	Stabilizers raised			5.4	6.7*	3.7	5.4	2.8	4.0	2.2	3.2	1.8	2.6	1.5	2.2					1.5	2.1	12.0
-1.5	4 pt. outriggers down			6.7*	6.7*	8.2*	8.2*	6.5*	6.5*	5.0	5.2*	4.1*	4.1*	2.7*	2.7*					2.7*	2.7*	12.0
-3.0	Stabilizers raised					3.6	5.4	2.7	4.0	2.1	3.1									1.8	2.6	10.5
-3.0	4 pt. outriggers down					6.6*	6.6*	5.4*	5.4*	4.2*	4.2*									3.1*	3.1*	10.5

Height **Can be slewed through 360°** **In longitudinal position of undercarriage** **Max. reach** * Limited by hydr. capacity

The lift capacities on the stick end without attachment are stated in metric tons (t) and are valid on a firm, level supporting surface with blocked oscillating axle. These capacities can be slewed through 360° with the undercarriage in the transverse position. Capacities in the longitudinal position of the undercarriage (+/- 15°) are specified over the steering axle with the stabilizers raised and over the rigid axle with the stabilizers down. Indicated loads based on the ISO 10567 standard and do not exceed 75% of tipping or 87% of hydraulic capacity. The lift capacity of the unit is limited by its stability, the lifting capability of the hydraulic elements, or the maximum permissible lifting capacity of the load hook.

In accordance with the harmonised European Standard EN 474-5, hydraulic excavators used for lifting operations must be equipped with pipe fracture safety valves, an overload warning device, a load hook and a lift capacity chart.

LH 30 M – Attachment GA14

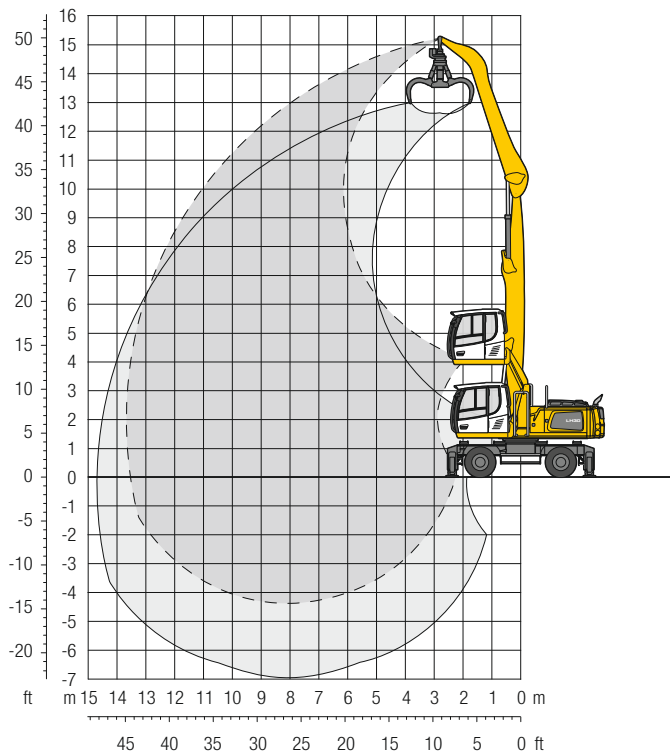

Operating Weight

The operating weight includes the basic machine with 4 point outriggers, hydr. cab elevation, 8 solid tyres plus intermediate rings, straight boom 7.80 m, angled stick 6.00 m and grab GM 65/0.60 m³ semi-closed tines.

Weight 28,900 kg

Dimensions

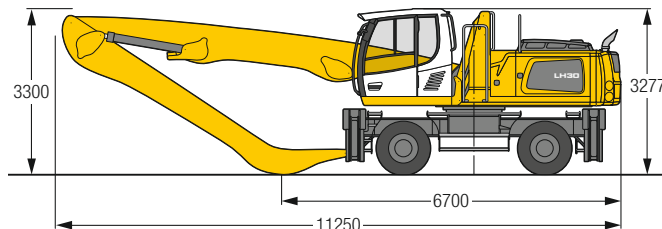

m	Undercarriage	3.0 m		4.5 m		6.0 m		7.5 m		9.0 m		10.5 m		12.0 m		13.5 m		15.0 m		m					
		Stabilizers raised	4 pt. outriggers down	Stabilizers raised	4 pt. outriggers down	Stabilizers raised	4 pt. outriggers down	Stabilizers raised	4 pt. outriggers down	Stabilizers raised	4 pt. outriggers down	Stabilizers raised	4 pt. outriggers down	Stabilizers raised	4 pt. outriggers down	Stabilizers raised	4 pt. outriggers down	Stabilizers raised	4 pt. outriggers down	Stabilizers raised	4 pt. outriggers down	Stabilizers raised	4 pt. outriggers down		
15.0	Stabilizers raised																				7.2*	7.2*	3.8		
	4 pt. outriggers down																					7.2*	7.2*		
13.5	Stabilizers raised					6.0	6.5*															4.2	4.9*	7.2	
	4 pt. outriggers down					6.5*	6.5*																4.9*	4.9*	
12.0	Stabilizers raised					6.3	7.2*	4.3	5.6	3.0	4.0											2.8	3.8	9.3	
	4 pt. outriggers down					7.2*	7.2*	6.4*	6.4*	4.7*	4.7*												4.2*	4.2*	
10.5	Stabilizers raised							4.4	5.7	3.1	4.2	2.2	3.1									2.1	2.9	10.7	
	4 pt. outriggers down							6.3*	6.3*	5.6*	5.6*	4.2*	4.2*										3.8*	3.8*	
9.0	Stabilizers raised							4.4	5.7	3.1	4.2	2.3	3.1									1.8	2.5	11.7	
	4 pt. outriggers down							6.3*	6.3*	5.5*	5.5*	4.7	4.9*										3.6*	3.6*	
7.5	Stabilizers raised					6.2	7.5*	4.3	5.6	3.1	4.1	2.3	3.1	1.7	2.4							1.5	2.2	12.5	
	4 pt. outriggers down					7.5*	7.5*	6.4*	6.4*	5.6*	5.6*	4.7	4.9*	3.7	4.3*								3.4	3.5*	
6.0	Stabilizers raised					5.9	7.8	4.0	5.4	2.9	4.0	2.2	3.0	1.7	2.3								1.3	2.0	13.1
	4 pt. outriggers down					7.9*	7.9*	6.6*	6.6*	5.7*	5.7*	4.6	5.0*	3.6	4.3*								3.1	3.4*	
4.5	Stabilizers raised	6.8*	6.8*	8.4	10.0*	5.4	7.2	3.7	5.1	2.8	3.8	2.1	2.9	1.6	2.3								1.2	1.8	13.4
	4 pt. outriggers down	6.8*	6.8*	10.0*	10.0*	8.4*	8.4*	6.9*	6.9*	5.7	5.8*	4.4	5.0*	3.6	4.3*								2.9	3.4*	
3.0	Stabilizers raised	7.1*	7.1*	7.2	10.1	4.7	6.6	3.4	4.7	2.5	3.5	2.0	2.8	1.5	2.2								1.2	1.7	13.6
	4 pt. outriggers down	7.1*	7.1*	12.1*	12.1*	9.0*	9.0*	7.1*	7.1*	5.5	5.9*	4.3	5.0*	3.5	4.2*	1.2	1.8						2.8	3.2*	
1.5	Stabilizers raised	1.1*	1.1*	6.0	8.9	4.2	5.9	3.1	4.3	2.3	3.3	1.8	2.6	1.4	2.1	1.2	1.7						1.1	1.7	13.7
	4 pt. outriggers down	1.1*	1.1*	9.1*	9.1*	9.2*	9.2*	6.9	7.2*	5.2	5.9*	4.2	4.9*	3.4	4.0*	2.8	3.1*						2.8	2.9*	
0	Stabilizers raised	1.5*	1.5*	5.3*	5.3*	3.7	5.4	2.8	4.0	2.1	3.1	1.7	2.5	1.4	2.0	1.1	1.7						1.1	1.7	13.5
	4 pt. outriggers down	1.5*	1.5*	5.3*	5.3*	8.9*	8.9*	6.5	7.0*	5.0	5.7*	4.0	4.6*	3.3	3.7*	2.6*	2.6*						2.6*	2.6*	
-1.5	Stabilizers raised	2.6*	2.6*	5.0	5.3*	3.5	5.2	2.6	3.8	2.0	3.0	1.6	2.4	1.3	2.0								1.2	1.8	13.2
	4 pt. outriggers down	2.6*	2.6*	5.3*	5.3*	8.0*	8.0*	6.3	6.4*	4.9	5.2*	3.9	4.2*	3.2*	3.2*								2.2*	2.2*	
-3.0	Stabilizers raised			5.0	6.0*	3.4	5.1	2.5	3.7	2.0	2.9	1.6	2.4										1.3	2.0	11.8
	4 pt. outriggers down			6.0*	6.0*	6.7*	6.7*	5.5*	5.5*	4.4*	4.4*	3.5*	3.5*										2.5*	2.5*	

Height **Can be slewed through 360°** **In longitudinal position of undercarriage** **Max. reach** * Limited by hydr. capacity

The lift capacities on the stick end without attachment are stated in metric tons (t) and are valid on a firm, level supporting surface with blocked oscillating axle. These capacities can be slewed through 360° with the undercarriage in the transverse position. Capacities in the longitudinal position of the undercarriage (+/- 15°) are specified over the steering axle with the stabilizers raised and over the rigid axle with the stabilizers down. Indicated loads based on the ISO 10567 standard and do not exceed 75% of tipping or 87% of hydraulic capacity. The lift capacity of the unit is limited by its stability, the lifting capability of the hydraulic elements, or the maximum permissible lifting capacity of the load hook.

In accordance with the harmonised European Standard EN 474-5, hydraulic excavators used for lifting operations must be equipped with pipe fracture safety valves, an overload warning device, a load hook and a lift capacity chart.

LH 30 M – Attachment GS10

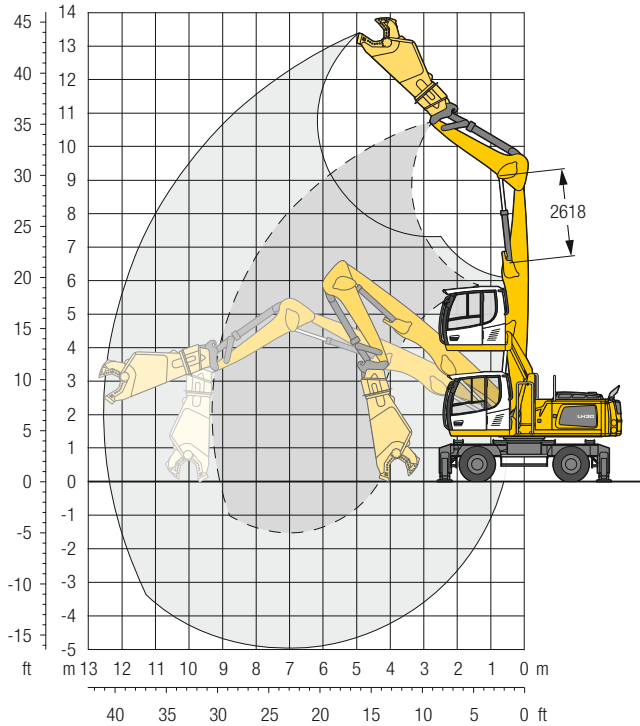

Operating Weight

The operating weight includes the basic machine with 4 point outriggers, hydr. cab elevation, 8 solid tyres plus intermediate rings, straight boom 6.80 m, stick HD with tipping kinematics special 3.20 m, quick coupler SWA 48 and scrap shear Genesis GXT 335R.

Weight 32,900 kg

A heavy counterweight (6,075 kg) is required for this attachment configuration. The stick cylinder must be limited to the measure of 2,618 mm.

Dimensions

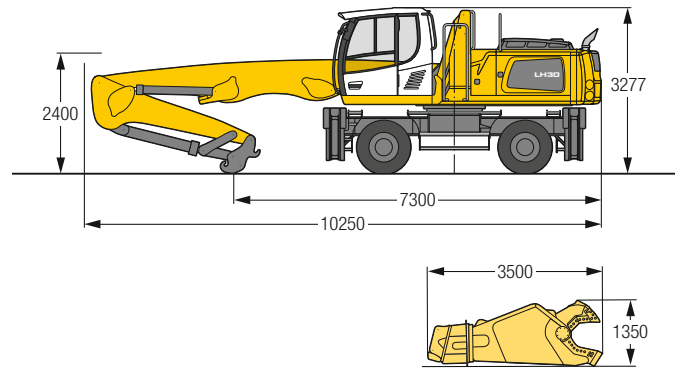

m	Undercarriage	3.0 m		4.5 m		6.0 m		7.5 m		9.0 m		10.5 m		12.0 m		13.5 m		15.0 m		Max. reach			
		Stabilizers raised	4 pt. outriggers down	Stabilizers raised	4 pt. outriggers down	Stabilizers raised	4 pt. outriggers down	Stabilizers raised	4 pt. outriggers down	Stabilizers raised	4 pt. outriggers down	Stabilizers raised	4 pt. outriggers down	Stabilizers raised	4 pt. outriggers down	Stabilizers raised	4 pt. outriggers down	Stabilizers raised	4 pt. outriggers down	Stabilizers raised	4 pt. outriggers down	m	
13.5	Stabilizers raised 4 pt. outriggers down																						
12.0	Stabilizers raised 4 pt. outriggers down					5.0*	5.0*														3.0	4.0*	7.4
10.5	Stabilizers raised 4 pt. outriggers down							3.2	3.8*	1.6	2.7										4.0*	4.0*	9.2
9.0	Stabilizers raised 4 pt. outriggers down							3.3	3.7*	1.7	2.8										0.6	1.6	10.4
7.5	Stabilizers raised 4 pt. outriggers down							3.7*	3.7*	2.9*	2.9*										2.3*	2.3*	11.3
6.0	Stabilizers raised 4 pt. outriggers down							3.2	3.7*	1.7	2.8	0.6	1.5								0.2	1.0	11.9
4.5	Stabilizers raised 4 pt. outriggers down							3.0	3.8*	1.5	2.6	0.5	1.4								1.9*	1.9*	12.3
3.0	Stabilizers raised 4 pt. outriggers down							3.8*	3.8*	3.0*	3.0*	2.3*	2.3*								1.6*	1.6*	12.5
1.5	Stabilizers raised 4 pt. outriggers down					4.1*	4.1*	2.6	4.0*	1.3	2.4	0.4	1.3	–	0.5						–	0.3	12.5
0	Stabilizers raised 4 pt. outriggers down			2.9*	2.9*	4.1*	4.1*	4.0*	4.0*	3.0*	3.0*	2.3*	2.3*	1.5*	1.5*						1.4*	1.4*	12.4
-1.5	Stabilizers raised 4 pt. outriggers down			2.9*	2.9*	4.1*	4.1*	4.0*	4.0*	3.0*	3.0*	2.3*	2.3*	1.5*	1.5*	–	0.4				–	0.2	12.0
-3.0	Stabilizers raised 4 pt. outriggers down			2.9*	2.9*	4.1*	4.1*	4.0*	4.0*	3.0*	3.0*	2.3*	2.3*	1.5*	1.5*	–	0.4				1.2*	1.2*	11.5
-4.5	Stabilizers raised 4 pt. outriggers down			5.9	9.1*	3.1	5.1	1.6	3.0	0.6	1.7	–	0.9	–	0.2						–	0.1	9.3
	Stabilizers raised 4 pt. outriggers down			9.1*	9.1*	6.1*	6.1*	4.3*	4.3*	3.0*	3.0*	2.1*	2.1*	1.2*	1.2*						0.9*	0.9*	
	Stabilizers raised 4 pt. outriggers down			4.3	7.4	2.3	4.2	1.1	2.5	0.3	1.4	–	0.7	–	0.1						–	–	
	Stabilizers raised 4 pt. outriggers down			9.0*	9.0*	6.0*	6.0*	4.1*	4.1*	2.9*	2.9*	1.9*	1.9*	0.9*	0.9*						0.7*	0.7*	
	Stabilizers raised 4 pt. outriggers down			3.4	5.7*	1.7	3.6	0.7	2.1	0.1	1.2	–	0.5	–	0.1						–	0.1	
	Stabilizers raised 4 pt. outriggers down			5.7*	5.7*	5.4*	5.4*	3.7*	3.7*	2.4*	2.4*	1.4*	1.4*	0.3*	0.3*						0.3*	0.3*	
	Stabilizers raised 4 pt. outriggers down			2.9	5.6*	1.4	3.2	0.5	1.9	–	1.0	–	0.4	–	–						–	–	
	Stabilizers raised 4 pt. outriggers down			5.6*	5.6*	4.2*	4.2*	2.8*	2.8*	1.7*	1.7*	0.6*	0.6*								–	–	
	Stabilizers raised 4 pt. outriggers down					1.3	2.5*	0.4	1.5*	–	0.5*	–	0.5*								–	0.3*	
	Stabilizers raised 4 pt. outriggers down					2.5*	2.5*	1.5*	1.5*	0.5*	0.5*										0.3*	0.3*	

Height
 Can be slewed through 360°
 In longitudinal position of undercarriage
 Max. reach
 * Limited by hydr. capacity

The lift capacities on the stick end without attachment are stated in metric tons (t) and are valid on a firm, level supporting surface with blocked oscillating axle. These capacities can be slewed through 360° with the undercarriage in the transverse position. Capacities in the longitudinal position of the undercarriage (+/- 15°) are specified over the steering axle with the stabilizers raised and over the rigid axle with the stabilizers down. Indicated loads based on the ISO 10567 standard and do not exceed 75% of tipping or 87% of hydraulic capacity. The maximum lift capacity for the quick coupler's load hook is 12 t. Without working tool the lift capacity will increase by 3,500 kg and without quick coupler, tipping cylinder, lever and connection link by an additional 805 kg. The lift capacity of the unit is limited by its stability, the lifting capability of the hydraulic elements, or the maximum permissible lifting capacity of the load hook.

In accordance with the harmonised European Standard EN 474-5, hydraulic excavators used for lifting operations must be equipped with pipe fracture safety valves, an overload warning device, a load hook and a lift capacity chart.

LH 30 M – Attachment GSV13

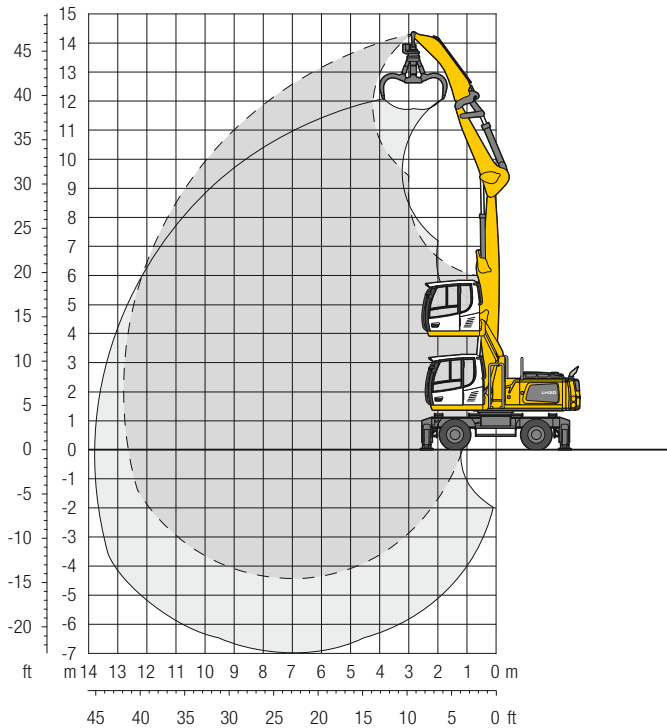

Operating Weight

The operating weight includes the basic machine with 4 point outriggers, hydr. cab elevation, 8 solid tyres plus intermediate rings, straight boom 6.80 m, stick HD with tipping kinematics special 3.20 m, quick coupler SWA 48, stick extension 2.70 m and grab GM 65/0.60 m³ semi-closed tines.

Weight 30,000 kg

A heavy counterweight (6,075 kg) is required for this attachment configuration.

Dimensions

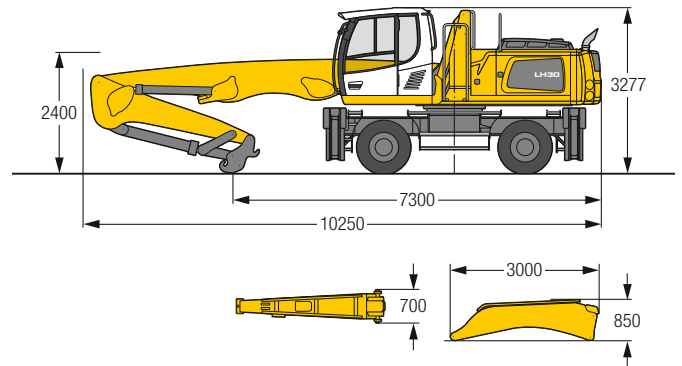

m	Undercarriage	3.0 m		4.5 m		6.0 m		7.5 m		9.0 m		10.5 m		12.0 m		13.5 m		15.0 m		m		
		Stabilizers raised	4 pt. outriggers down	Stabilizers raised	4 pt. outriggers down	Stabilizers raised	4 pt. outriggers down	Stabilizers raised	4 pt. outriggers down	Stabilizers raised	4 pt. outriggers down	Stabilizers raised	4 pt. outriggers down	Stabilizers raised	4 pt. outriggers down	Stabilizers raised	4 pt. outriggers down	Stabilizers raised	4 pt. outriggers down	Stabilizers raised	4 pt. outriggers down	Stabilizers raised
13.5				6.8*	6.8*															5.2*	5.2*	5.6
12.0						6.4*	6.4*	4.4	5.0*											3.8	4.0*	8.1
10.5								4.7	5.9*	3.2	4.3									4.0*	4.0*	9.7
9.0								4.7	5.9*	4.7*	4.7*									2.6	3.4*	10.8
7.5								4.8	5.8*	3.3	4.4	2.2	3.1							3.4*	3.4*	11.7
6.0								5.8*	5.8*	5.1*	5.1*	3.9*	3.9*							2.0	2.9	12.3
4.5								4.7	5.8*	3.2	4.4	2.3	3.2							3.1*	3.1*	12.7
3.0								5.8*	5.8*	5.1*	5.1*	4.4*	4.4*							1.7	2.4	12.9
1.5								6.7	7.0*	4.5	5.9*	3.1	4.2	1.5	2.3					2.9*	2.9*	12.7
0								7.0*	7.0*	5.9*	5.9*	5.1*	5.1*	3.6*	3.6*					1.4	2.2	12.3
-1.5								6.2	7.4*	4.2	5.6	2.9	4.0	4.4*	4.4*	3.6	3.6*			2.9*	2.9*	12.7
-3.0								7.4*	7.4*	6.2*	6.2*	5.2*	5.2*	4.4*	4.4*	3.6	3.6*			2.8*	2.8*	12.7
-4.5								6.9*	6.9*	8.9	10.5*	5.5	7.6	3.8	5.2	2.7	3.8	1.9	2.8	1.2	1.8	12.9
								6.9*	6.9*	10.5*	10.5*	8.0*	8.0*	6.4*	6.4*	5.3*	5.3*	4.4*	4.4*	2.9*	2.9*	12.9
								7.6*	7.6*	7.4	10.6	4.8	6.8	3.4	4.8	2.4	3.5	1.8	2.7	1.3	2.1	12.9
								7.6*	7.6*	11.5*	11.5*	8.4*	8.4*	6.5*	6.5*	5.2*	5.2*	4.3*	4.3*	3.3*	3.3*	12.9
								3.2*	3.2*	6.3	9.4	4.2	6.1	3.0	4.4	2.2	3.3	1.7	2.5	1.3	2.0	12.7
								3.2*	3.2*	11.5*	11.5*	8.3*	8.3*	6.4*	6.4*	5.0*	5.0*	4.0*	4.0*	2.9*	2.9*	12.7
								3.6*	3.6*	5.7	8.7	3.8	5.7	2.7	4.1	2.0	3.1	1.6	2.4	1.2	2.0	12.4
								3.6*	3.6*	9.2*	9.2*	7.7*	7.7*	5.9*	5.9*	4.6*	4.6*	3.5*	3.5*	2.2*	2.2*	12.4
								4.6*	4.6*	5.4	8.3*	3.6	5.4	2.6	3.9	1.9	3.0	1.5	2.4			11.1
								4.6*	4.6*	8.3*	8.3*	6.4*	6.4*	5.0*	5.0*	3.8*	3.8*	2.6*	2.6*			7.4
																				2.6	3.5*	7.4
																				3.5*	3.5*	7.4

Height **Can be slewed through 360°** **In longitudinal position of undercarriage** **Max. reach** * Limited by hydr. capacity

The lift capacities on the end of the stick extension without attachment are stated in metric tons (t) and are valid on a firm, level supporting surface with blocked oscillating axle. These capacities can be slewed through 360° with the undercarriage in the transverse position. Capacities in the longitudinal position of the undercarriage (+/- 15°) are specified over the steering axle with the stabilizers raised and over the rigid axle with the stabilizers down. Indicated loads based on the ISO 10567 standard and do not exceed 75% of tipping or 87% of hydraulic capacity. The lift capacity of the unit is limited by its stability, the lifting capability of the hydraulic elements, or the maximum permissible lifting capacity of the load hook.

In accordance with the harmonised European Standard EN 474-5, hydraulic excavators used for lifting operations must be equipped with pipe fracture safety valves, an overload warning device, a load hook and a lift capacity chart.

LH 30 M – Attachment GK12

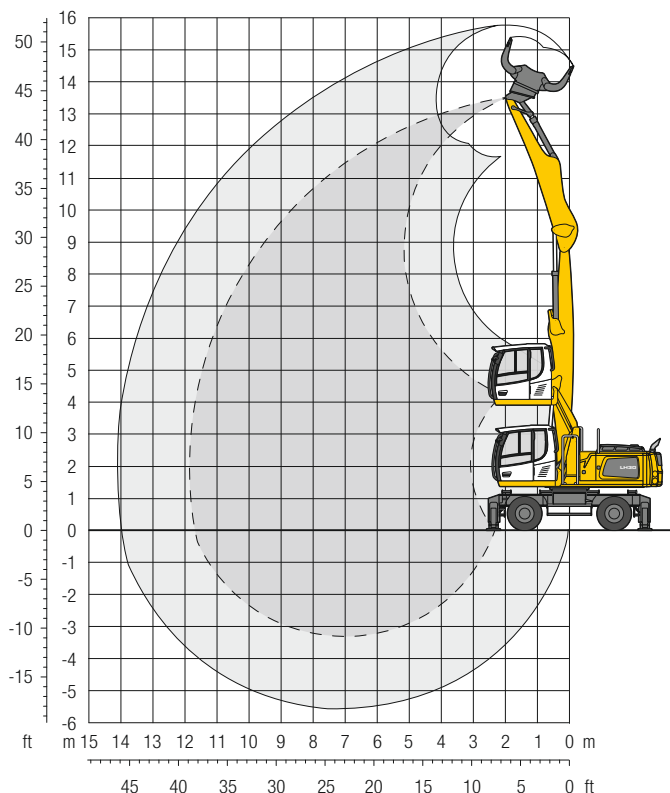

Operating Weight

The operating weight includes the basic machine with 4 point outriggers, hydr. cab elevation, 8 solid tyres plus intermediate rings, straight boom 6.80 m, stick with tipping kinematics 5.00 m and sorting grab SG 30B/0.85 m³ shells.

Weight 29,100 kg

Dimensions

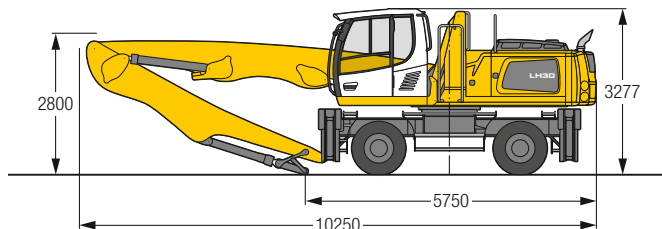

m	Undercarriage	3.0 m		4.5 m		6.0 m		7.5 m		9.0 m		10.5 m		12.0 m		13.5 m		15.0 m		m			
		Stabilizers raised	4 pt. outriggers down	Stabilizers raised	4 pt. outriggers down	Stabilizers raised	4 pt. outriggers down	Stabilizers raised	4 pt. outriggers down	Stabilizers raised	4 pt. outriggers down	Stabilizers raised	4 pt. outriggers down	Stabilizers raised	4 pt. outriggers down	Stabilizers raised	4 pt. outriggers down	Stabilizers raised	4 pt. outriggers down	Stabilizers raised	4 pt. outriggers down	Stabilizers raised	4 pt. outriggers down
13.5	Stabilizers raised 4 pt. outriggers down																				12.1*	12.1*	2.1
12.0	Stabilizers raised 4 pt. outriggers down			8.8	8.9*	5.3	6.7*														5.0	6.1*	6.2
10.5	Stabilizers raised 4 pt. outriggers down			8.9*	8.9*	6.7*	6.7*	5.7	7.6	3.8	5.1										6.1*	6.1*	8.2
9.0	Stabilizers raised 4 pt. outriggers down					7.8*	7.8*	6.7*	6.7*	5.7	7.6	3.9	5.2	2.7	3.7						4.9*	4.9*	9.5
7.5	Stabilizers raised 4 pt. outriggers down					5.8	7.6*	3.9	5.2	7.6*	7.6*	6.6*	6.6*	5.6	5.8*						2.3	3.3	10.5
6.0	Stabilizers raised 4 pt. outriggers down					7.6*	7.6*	6.6*	6.6*	5.7	7.6	3.9	5.2	2.7	3.7						4.4*	4.4*	11.2
4.5	Stabilizers raised 4 pt. outriggers down					5.7	7.6	3.9	5.2	7.7*	7.7*	6.6*	6.6*	5.7	5.8*						1.9	2.7	11.6
3.0	Stabilizers raised 4 pt. outriggers down			8.8*	8.8*	5.5	7.4	3.7	5.0	8.8*	8.8*	8.1*	8.1*	6.8*	6.8*	1.9	2.7				1.6	2.4	11.8
1.5	Stabilizers raised 4 pt. outriggers down	7.0*	7.0*	8.8*	8.8*	8.1*	8.1*	6.8*	6.8*	7.0*	7.0*	5.5	5.9*	4.2	4.9*	4.3	5.0*				3.8	4.0*	11.7
0	Stabilizers raised 4 pt. outriggers down	7.0*	7.0*	10.9*	10.9*	8.6*	8.6*	7.0*	7.0*	5.5	5.9*	4.2	4.9*	3.5	3.9*	4.3	5.0*				1.5	2.2	10.9
-1.5	Stabilizers raised 4 pt. outriggers down	8.4*	8.4*	7.1	10.1	4.6	6.4	3.3	4.5	8.4*	8.4*	12.3*	9.1*	9.1*	7.1	7.2*	5.3	5.9*	4.1	4.8*	1.4	2.1	8.8
-3.0	Stabilizers raised 4 pt. outriggers down	8.4*	8.4*	7.1	10.1	4.6	6.4	3.3	4.5	6.2	9.1	4.2	5.9	3.0	4.3	2.2	3.2	1.7	2.5	3.4	3.7*		
	Stabilizers raised 4 pt. outriggers down			6.2	9.1	4.2	5.9	3.0	4.3	12.8*	12.8*	9.3*	9.3*	6.8	7.2*	5.1	5.8*	4.0	4.6*	1.4	2.1		
	Stabilizers raised 4 pt. outriggers down	1.6*	1.6*	5.7	7.4*	3.8	5.6	2.8	4.1	1.6*	1.6*	7.4*	7.4*	8.9*	8.9*	6.6	6.9*	5.0	5.4*	1.4	2.1		
	Stabilizers raised 4 pt. outriggers down	5.4	7.5*	3.6	5.4	2.7	3.9	2.0	3.0	1.6*	1.6*	7.5*	7.5*	7.8*	7.8*	6.1*	6.1*	4.7*	4.7*	2.7*	2.7*		
	Stabilizers raised 4 pt. outriggers down			3.6	5.3	2.6	3.9			4.7*	4.7*	3.3*	3.3*	2.1	2.4	2.1	2.4	1.6	2.4	1.5	2.3		
	Stabilizers raised 4 pt. outriggers down			6.1*	6.1*	4.8*	4.8*														2.8*	2.8*	
	Stabilizers raised 4 pt. outriggers down																				2.1	3.1	8.8
	Stabilizers raised 4 pt. outriggers down																				3.7*	3.7*	

Height Can be slewed through 360° In longitudinal position of undercarriage Max. reach * Limited by hydr. capacity

The lift capacities on the stick end without attachment are stated in metric tons (t) and are valid on a firm, level supporting surface with blocked oscillating axle. These capacities can be slewed through 360° with the undercarriage in the transverse position. Capacities in the longitudinal position of the undercarriage (+/- 15°) are specified over the steering axle with the stabilizers raised and over the rigid axle with the stabilizers down. Indicated loads based on the ISO 10567 standard and do not exceed 75% of tipping or 87% of hydraulic capacity. The lift capacity of the unit is limited by its stability, the lifting capability of the hydraulic elements, or the maximum permissible lifting capacity of the load hook.

In accordance with the harmonised European Standard EN 474-5, hydraulic excavators used for lifting operations must be equipped with pipe fracture safety valves, an overload warning device, a load hook and a lift capacity chart.

LH 35 M – Attachment GK13

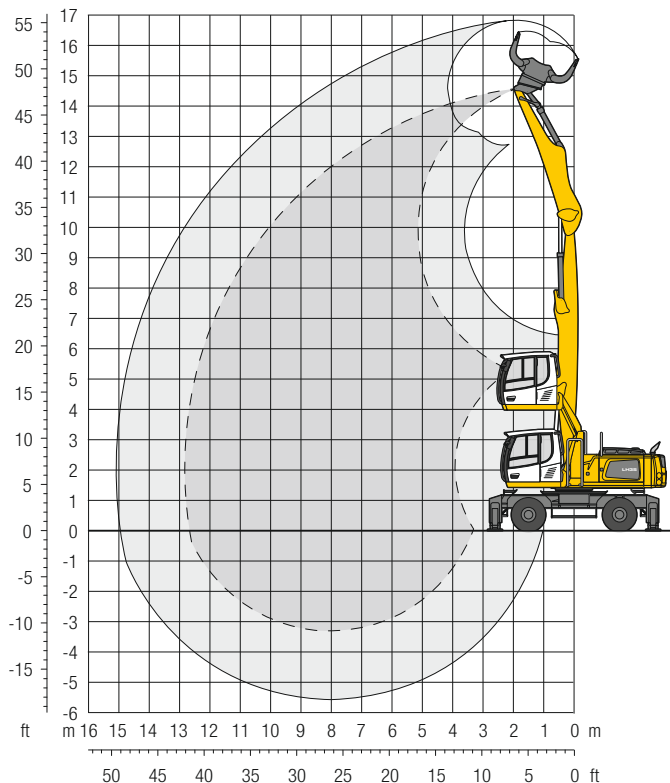

Operating Weight

The operating weight includes the basic machine with 4 point outriggers, hydr. cab elevation, 8 solid tyres plus intermediate rings, straight boom 7.80 m, stick with tipping kinematics 5.00 m and sorting grab SG 30B/0.85 m³ shells.

Weight 33,500 kg

Dimensions

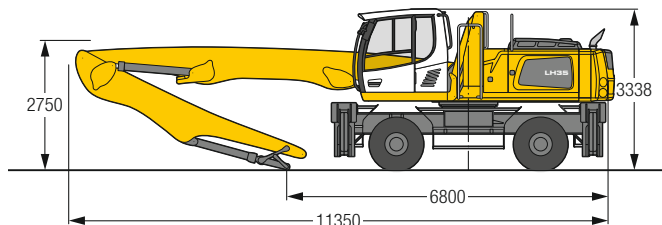

m	Undercarriage	3.0 m		4.5 m		6.0 m		7.5 m		9.0 m		10.5 m		12.0 m		13.5 m		15.0 m		m			
		Stabilizers raised	4 pt. outriggers down	Stabilizers raised	4 pt. outriggers down	Stabilizers raised	4 pt. outriggers down	Stabilizers raised	4 pt. outriggers down	Stabilizers raised	4 pt. outriggers down	Stabilizers raised	4 pt. outriggers down	Stabilizers raised	4 pt. outriggers down	Stabilizers raised	4 pt. outriggers down	Stabilizers raised	4 pt. outriggers down	Stabilizers raised	4 pt. outriggers down	Stabilizers raised	4 pt. outriggers down
13.5	Stabilizers raised 4 pt. outriggers down			8.7*	8.7*																6.8*	6.8*	5.6
12.0	Stabilizers raised 4 pt. outriggers down					7.6	7.8*	5.2	6.6*												4.5	5.3*	8.0
10.5	Stabilizers raised 4 pt. outriggers down					7.5*	7.5*	5.4	6.4*	3.8	4.9										5.3*	5.3*	9.6
9.0	Stabilizers raised 4 pt. outriggers down					7.5*	7.5*	5.4	6.4*	3.9	5.0	2.9	3.7								2.7	3.5	10.8
7.5	Stabilizers raised 4 pt. outriggers down					7.6	7.8*	5.3	6.5*	3.8	4.9	2.9	3.8								4.2*	4.2*	11.6
6.0	Stabilizers raised 4 pt. outriggers down			9.7*	9.7*	7.8*	7.8*	6.5*	6.5*	5.5*	5.5*	4.7*	4.7*								2.3	3.1	12.2
4.5	Stabilizers raised 4 pt. outriggers down			9.7*	9.7*	7.2	8.2*	5.0	6.5	3.7	4.8	2.8	3.7	2.1	2.9						4.0*	4.0*	12.6
3.0	Stabilizers raised 4 pt. outriggers down			10.3	11.6*	8.2*	8.2*	6.7*	6.7*	4.8	5.6*	5.6*	4.7*	3.9*	3.9*						2.1	2.8	12.8
1.5	Stabilizers raised 4 pt. outriggers down			11.6*	11.6*	6.7	8.6*	4.7	6.2	3.5	4.6	2.7	3.6	2.1	2.8						3.8*	3.8*	12.7
0	Stabilizers raised 4 pt. outriggers down			9.0	9.7*	6.1	8.1	4.4	5.8	3.3	4.4	2.6	3.5	2.1	2.8						1.9	2.6	11.9
-1.5	Stabilizers raised 4 pt. outriggers down			9.7*	9.7*	8.9*	8.9*	7.0*	7.0*	5.6*	5.6*	4.6*	4.6*	3.7*	3.7*						3.4*	3.4*	9.7
-3.0	Stabilizers raised 4 pt. outriggers down			3.0*	3.0*	5.6	7.5	4.1	5.5	3.2	4.2	2.5	3.4	2.0	2.7						1.8	2.5	
	Stabilizers raised 4 pt. outriggers down			3.0*	3.0*	8.8*	8.8*	6.8*	6.8*	5.5*	5.5*	4.4*	4.4*	3.4*	3.4*						1.8	2.2*	
	Stabilizers raised 4 pt. outriggers down			3.1*	3.1*	5.2	7.2	3.9	5.3	3.0	4.1	2.4	3.3	2.0	2.7						2.7*	2.7*	
	Stabilizers raised 4 pt. outriggers down			3.1*	3.1*	8.1*	8.1*	6.4*	6.4*	5.1*	5.1*	4.0*	4.0*	3.0*	3.0*						1.8	2.2*	
	Stabilizers raised 4 pt. outriggers down			4.2*	4.2*	5.1	6.8*	3.8	5.1	2.9	4.0	2.4	3.2								2.0	2.3*	
	Stabilizers raised 4 pt. outriggers down			4.2*	4.2*	6.8*	6.8*	5.5*	5.5*	4.4*	4.4*	3.4*	3.4*								2.3*	2.3*	
	Stabilizers raised 4 pt. outriggers down							3.7	4.3*	2.9	3.4*										2.6	2.9*	
	Stabilizers raised 4 pt. outriggers down							4.3*	4.3*	3.4*	3.4*										2.9*	2.9*	

Height Can be slewed through 360° In longitudinal position of undercarriage Max. reach * Limited by hydr. capacity

The lift capacities on the stick end without attachment are stated in metric tons (t) and are valid on a firm, level supporting surface with blocked oscillating axle. These capacities can be slewed through 360° with the undercarriage in the transverse position. Capacities in the longitudinal position of the undercarriage (+/- 15°) are specified over the steering axle with the stabilizers raised and over the rigid axle with the stabilizers down. Indicated loads based on the ISO 10567 standard and do not exceed 75% of tipping or 87% of hydraulic capacity. The lift capacity of the unit is limited by its stability, the lifting capability of the hydraulic elements, or the maximum permissible lifting capacity of the load hook.

In accordance with the harmonised European Standard EN 474-5, hydraulic excavators used for lifting operations must be equipped with pipe fracture safety valves, an overload warning device, a load hook and a lift capacity chart.

LH 35 M – Attachment GA14

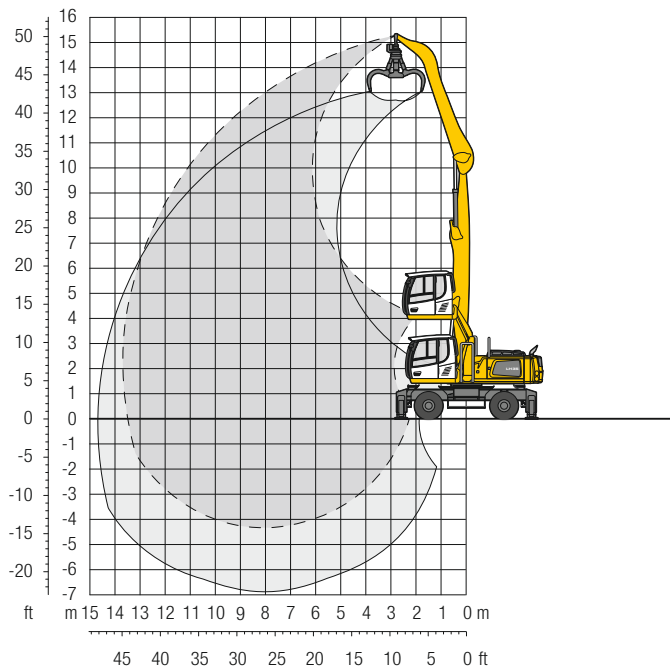

Operating Weight

The operating weight includes the basic machine with 4 point outriggers, hydr. cab elevation, 8 solid tyres plus intermediate rings, straight boom 7.80 m, angled stick 6.00 m and grab GM 65/0.60 m³ semi-closed tines.

Weight 33,100 kg

Dimensions

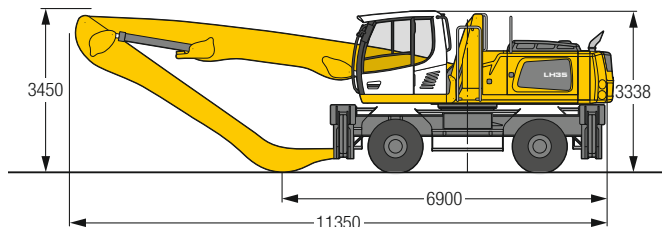

m	3.0 m		4.5 m		6.0 m		7.5 m		9.0 m		10.5 m		12.0 m		13.5 m		15.0 m		m			
	Stabilizers raised	4 pt. outriggers down	Stabilizers raised	4 pt. outriggers down	Stabilizers raised	4 pt. outriggers down	Stabilizers raised	4 pt. outriggers down	Stabilizers raised	4 pt. outriggers down	Stabilizers raised	4 pt. outriggers down	Stabilizers raised	4 pt. outriggers down	Stabilizers raised	4 pt. outriggers down	Stabilizers raised	4 pt. outriggers down	Stabilizers raised	4 pt. outriggers down		
16.5																						
15.0																				7.0*	7.0*	
13.5					6.6*	6.6*														4.8*	4.8*	
12.0					7.3*	7.3*	5.8	6.4*	4.2	4.8*										4.8*	4.8*	
10.5					7.3*	7.3*	5.9	6.3*	4.3	5.4	3.2	4.1								3.9	4.1*	
9.0							6.3*	6.3*	5.6*	5.6*	4.3*	4.3*								4.1*	4.1*	
7.5					7.5*	7.5*	5.8	6.4*	4.3	5.4	3.3	4.2	2.5	3.3						3.1	3.8*	
6.0					7.5*	7.5*	6.4*	6.4*	5.6*	5.6*	4.9*	4.9*	4.3*	4.3*						3.8*	3.8*	
4.5					7.8	7.9*	5.5	6.6*	4.1	5.2	3.2	4.1	2.5	3.2						2.6	3.4	
3.0					7.9*	7.9*	6.6*	6.6*	5.7*	5.7*	5.0*	5.0*	4.3*	4.3*						3.6*	3.6*	
1.5					7.1*	7.1*	10.3*	10.3*	7.3	8.5*	3.9	5.0	3.1	4.0	2.4	3.2				2.3	3.0	
0					7.1*	7.1*	10.3*	10.3*	6.4*	6.4*	5.6*	5.6*	4.9*	4.9*	4.3*	4.3*				3.4*	3.4*	
-1.5					5.6*	5.6*	10.0	12.2*	6.7	8.7	4.9	6.3	3.7	4.8	2.9	3.8	2.4	3.1	1.9	2.5	2.1	2.8
-3.0					5.6*	5.6*	12.2*	12.2*	9.0*	9.0*	7.1*	7.1*	5.9*	5.9*	5.0*	5.0*	4.2*	4.2*	3.3*	3.3*	3.4*	3.4*
-4.5					1.1*	1.1*	8.6*	8.6*	6.1	8.1	4.5	5.9	3.5	4.6	2.8	3.7	2.3	3.0	1.9	2.5	2.0	2.6
					1.1*	1.1*	8.6*	9.2*	9.2*	7.2*	7.2*	5.9*	5.9*	4.9*	4.9*	4.0*	4.0*	3.1*	3.1*	3.4*	3.4*	
					1.6*	1.6*	5.3*	5.3*	5.6	7.6	4.2	5.6	3.3	4.4	2.7	3.6	2.2	2.9	1.9	2.5	1.9	2.5
					1.6*	1.6*	5.3*	5.3*	8.9*	8.9*	7.0*	7.0*	5.6*	5.6*	4.6*	4.6*	3.7*	3.7*	2.6*	2.6*	2.2	2.5*
					2.6*	2.6*	5.3*	5.3*	5.4	7.3	4.1	5.4	3.2	4.3	2.6	3.5	2.2	2.9			1.9	2.2*
					2.6*	2.6*	5.3*	5.3*	8.0*	8.0*	6.4*	6.4*	5.2*	5.2*	4.2*	4.2*	3.2*	3.2*			2.2*	2.2*
							6.0*	6.0*	5.3	6.6*	4.0	5.3	3.1	4.2	2.6	3.4*					2.2	2.5*
							6.0*	6.0*	6.6*	6.6*	5.4*	5.4*	4.4*	4.4*	3.4*	3.4*					2.5*	2.5*

Height Can be slewed through 360° In longitudinal position of undercarriage Max. reach * Limited by hydr. capacity

The lift capacities on the stick end without attachment are stated in metric tons (t) and are valid on a firm, level supporting surface with blocked oscillating axle. These capacities can be slewed through 360° with the undercarriage in the transverse position. Capacities in the longitudinal position of the undercarriage (+/- 15°) are specified over the steering axle with the stabilizers raised and over the rigid axle with the stabilizers down. Indicated loads based on the ISO 10567 standard and do not exceed 75% of tipping or 87% of hydraulic capacity. The lift capacity of the unit is limited by its stability, the lifting capability of the hydraulic elements, or the maximum permissible lifting capacity of the load hook.

In accordance with the harmonised European Standard EN 474-5, hydraulic excavators used for lifting operations must be equipped with pipe fracture safety valves, an overload warning device, a load hook and a lift capacity chart.

LH 35 M – Attachment GA15

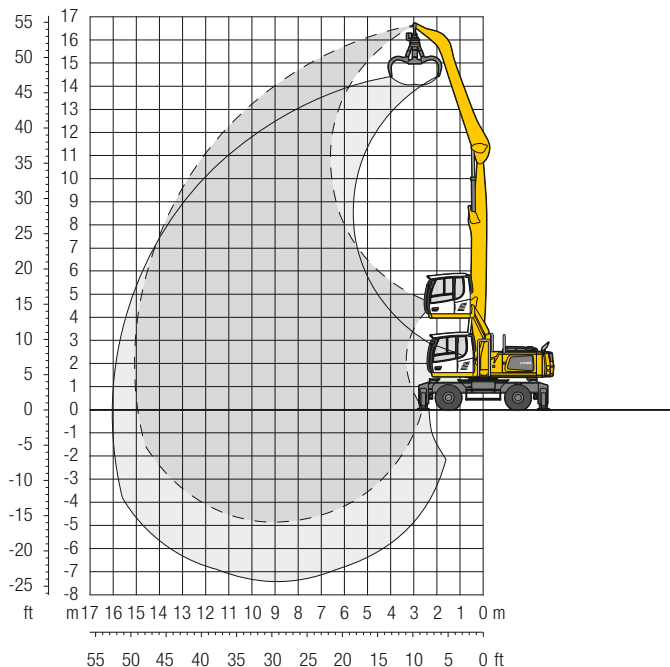

Operating Weight

The operating weight includes the basic machine with 4 point outriggers, hydr. cab elevation, 8 solid tyres plus intermediate rings, straight boom 8.70 m, angled stick 6.50 m and grab GM 65/0.60 m³ semi-closed tines.

Weight 33,500 kg

Dimensions

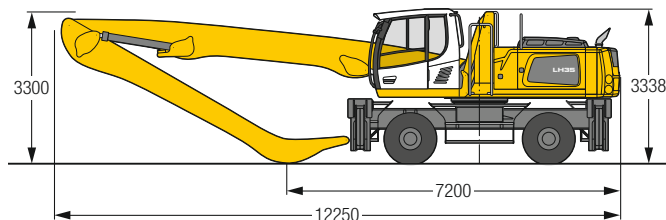

m	Undercarriage	3.0 m		4.5 m		6.0 m		7.5 m		9.0 m		10.5 m		12.0 m		13.5 m		15.0 m		m				
		Stabilizers raised	4 pt. outriggers down	Stabilizers raised	4 pt. outriggers down	Stabilizers raised	4 pt. outriggers down	Stabilizers raised	4 pt. outriggers down	Stabilizers raised	4 pt. outriggers down	Stabilizers raised	4 pt. outriggers down	Stabilizers raised	4 pt. outriggers down	Stabilizers raised	4 pt. outriggers down	Stabilizers raised	4 pt. outriggers down	Stabilizers raised	4 pt. outriggers down	Stabilizers raised	4 pt. outriggers down	
16.5	Stabilizers raised																				7.0*	7.0*	3.8	
16.5	4 pt. outriggers down																					7.0*	7.0*	3.8
15.0	Stabilizers raised					6.2*	6.2*	4.7*	4.7*													4.6*	4.6*	7.5
15.0	4 pt. outriggers down					6.2*	6.2*	4.7*	4.7*													4.6*	4.6*	7.5
13.5	Stabilizers raised							5.9	6.1*	4.2	4.9*											3.6	3.9*	9.7
13.5	4 pt. outriggers down							6.1*	6.1*	4.9*	4.9*											3.9*	3.9*	9.7
12.0	Stabilizers raised							6.0*	6.0*	4.4	5.2*	3.2	4.1									2.8	3.5*	11.3
12.0	4 pt. outriggers down							6.0*	6.0*	5.2*	5.2*	4.6*	4.6*									3.5*	3.5*	11.3
10.5	Stabilizers raised							6.0*	6.0*	4.4	5.2*	3.3	4.2	2.5	3.2							2.3	3.0	12.4
10.5	4 pt. outriggers down							6.0*	6.0*	5.2*	5.2*	4.6*	4.6*	4.1*	4.1*							3.3*	3.3*	12.4
9.0	Stabilizers raised							5.9	6.0*	4.4	5.2*	3.3	4.2	2.5	3.3							2.0	2.6	13.4
9.0	4 pt. outriggers down							6.0*	6.0*	5.2*	5.2*	4.6*	4.6*	4.1*	4.1*							3.2*	3.2*	13.4
7.5	Stabilizers raised					7.3*	7.3*	5.7	6.2*	4.2	5.3*	3.2	4.1	2.5	3.2	1.9	2.6					1.7	2.3	14.0
7.5	4 pt. outriggers down					7.3*	7.3*	6.2*	6.2*	5.3*	5.3*	4.6*	4.6*	4.0*	4.0*	3.5*	3.5*					3.1*	3.1*	14.0
6.0	Stabilizers raised					7.7	7.8*	5.4	6.4*	4.0	5.1	3.1	4.0	2.4	3.1	1.9	2.5					1.6	2.2	14.5
6.0	4 pt. outriggers down					7.8*	7.8*	6.4*	6.4*	5.4*	5.4*	4.7*	4.7*	4.0*	4.0*	3.5*	3.5*					3.0*	3.0*	14.5
4.5	Stabilizers raised	7.6*	7.6*	10.8*	10.8*	7.1	8.2*	5.0	6.5	3.8	4.9	2.9	3.8	2.3	3.0	1.8	2.5					1.5	2.0	14.9
4.5	4 pt. outriggers down	7.6*	7.6*	10.8*	10.8*	8.2*	8.2*	6.6*	6.6*	5.5*	5.5*	4.7*	4.7*	4.0*	4.0*	3.4*	3.4*					2.8*	2.8*	14.9
3.0	Stabilizers raised			9.3	11.8*	6.3	8.3	4.6	6.0	3.5	4.6	2.7	3.6	2.2	2.9	1.8	2.4					1.4	2.0	15.0
3.0	4 pt. outriggers down			11.8*	11.8*	8.6*	8.6*	6.8*	6.8*	5.6*	5.6*	4.7*	4.7*	4.0*	4.0*	3.3*	3.3*	2.6*	2.6*			2.6*	2.6*	15.0
1.5	Stabilizers raised			4.0*	4.0*	5.6	7.5	4.1	5.5	3.2	4.3	2.6	3.4	2.1	2.8	1.7	2.3	1.4	2.0			1.4	1.9	15.0
1.5	4 pt. outriggers down			4.0*	4.0*	8.6*	8.6*	6.8*	6.8*	5.5*	5.5*	4.6*	4.6*	3.8*	3.8*	3.2*	3.2*	2.3*	2.3*			2.3*	2.3*	15.0
0	Stabilizers raised	0.7*	0.7*	3.1*	3.1*	5.0	7.0	3.8	5.2	3.0	4.1	2.4	3.3	2.0	2.7	1.6	2.3					1.4	2.0	14.9
0	4 pt. outriggers down	0.7*	0.7*	3.1*	3.1*	8.2*	8.2*	6.5*	6.5*	5.3*	5.3*	4.4*	4.4*	3.6*	3.6*	2.9*	2.9*					2.0*	2.0*	14.9
-1.5	Stabilizers raised			3.5*	3.5*	4.8	6.7	3.6	4.9	2.8	3.9	2.3	3.2	1.9	2.6	1.6	2.2					1.4	1.7*	14.6
-1.5	4 pt. outriggers down			3.5*	3.5*	7.3*	7.3*	5.9*	5.9*	4.8*	4.8*	4.0*	4.0*	3.2*	3.2*	2.5*	2.5*					1.7*	1.7*	14.6
-3.0	Stabilizers raised			4.2*	4.2*	4.6	6.0*	3.5	4.8	2.7	3.8	2.2	3.1	1.9	2.6							1.6	1.8*	13.5
-3.0	4 pt. outriggers down			4.2*	4.2*	6.0*	6.0*	5.0*	5.0*	4.2*	4.2*	3.4*	3.4*	2.7*	2.7*							1.8*	1.8*	13.5
-4.5	Stabilizers raised							3.4	3.9*	2.7	3.2*	2.2	2.6*									2.1	2.4*	11.0
-4.5	4 pt. outriggers down							3.9*	3.9*	3.2*	3.2*	2.6*	2.6*									2.4*	2.4*	11.0

Height **Can be slewed through 360°** **In longitudinal position of undercarriage** **Max. reach** * Limited by hydr. capacity

The lift capacities on the stick end without attachment are stated in metric tons (t) and are valid on a firm, level supporting surface with blocked oscillating axle. These capacities can be slewed through 360° with the undercarriage in the transverse position. Capacities in the longitudinal position of the undercarriage (+/- 15°) are specified over the steering axle with the stabilizers raised and over the rigid axle with the stabilizers down. Indicated loads based on the ISO 10567 standard and do not exceed 75% of tipping or 87% of hydraulic capacity. The lift capacity of the unit is limited by its stability, the lifting capability of the hydraulic elements, or the maximum permissible lifting capacity of the load hook.

In accordance with the harmonised European Standard EN 474-5, hydraulic excavators used for lifting operations must be equipped with pipe fracture safety valves, an overload warning device, a load hook and a lift capacity chart.

LH 30 C LC – Attachment GK10

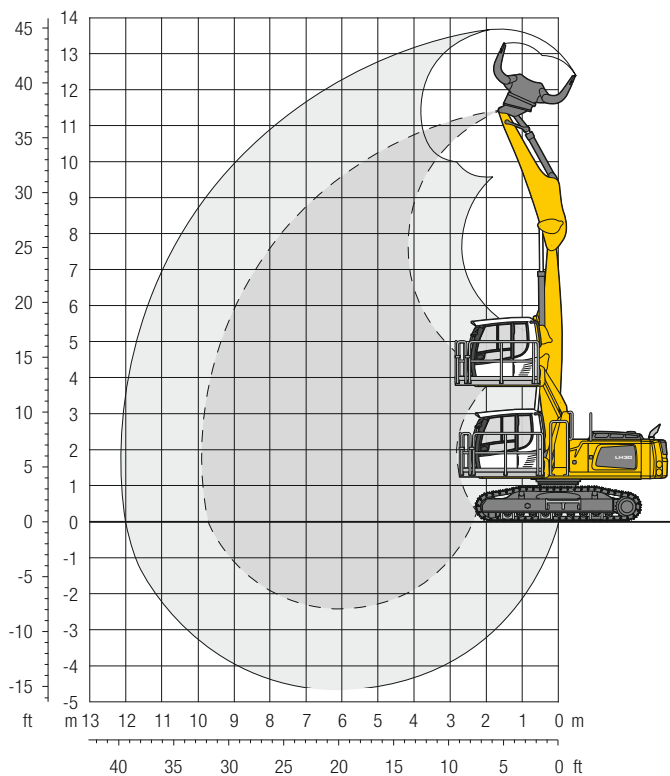

Operating Weight and Ground Pressure

The operating weight includes the basic machine with hydr. cab elevation, straight boom 5.80 m, stick with tipping kinematics 4.00 m and sorting grab SG 30B/0.85 m³ tines.

Weight	29,600 kg
Pad width	600 mm
Ground pressure	on request

Dimensions

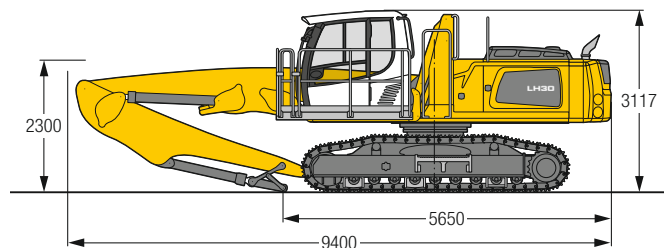

m	Undercarriage	3.0 m		4.5 m		6.0 m		7.5 m		9.0 m		10.5 m		12.0 m		13.5 m		15.0 m		m		
		LC	LC	LC	LC	LC	LC	LC	LC	LC	LC	LC	LC	LC	LC	LC	LC	LC	LC	LC	LC	LC
10.5	LC	12.2*	12.2*																	8.7*	8.7*	4.4
9.0	LC			10.6*	10.6*	7.5	8.9*													6.2	6.5*	6.7
7.5	LC			10.2*	10.2*	7.6	8.6*	5.3	7.5*											4.7	5.7*	8.0
6.0	LC			10.6*	10.6*	7.6	8.8*	5.3	7.5*											3.9	5.3*	8.9
4.5	LC	10.5*	10.5*	11.5	11.6*	7.3	9.2*	5.2	7.6*	3.9	6.0									3.5	5.1*	9.5
3.0	LC	19.8*	19.8*	10.8	12.9*	7.0	9.7*	5.0	7.7*	3.8	5.9									3.3	5.1*	9.8
1.5	LC	2.5*	2.5*	10.0	13.5*	6.6	9.8*	4.8	7.6*	3.7	5.8*									3.2	4.5*	9.9
0	LC	3.2*	3.2*	9.6	12.7*	6.4	9.3*	4.7	7.1*	3.7	5.1*									3.3	3.8*	9.7
-1.5	LC			9.4	10.4*	6.3	7.9*	4.6	5.9*											3.8	4.2*	8.7

Height **Can be slewed through 360°** **In longitudinal position of undercarriage** **Max. reach** * Limited by hydr. capacity

The lift capacities on the stick end without attachment are stated in metric tons (t) and can be slewed through 360° on a firm, level supporting surface. Capacities are valid for 600 mm wide triple grouser pads. Indicated loads based on the ISO 10567 standard and do not exceed 75% of tipping or 87% of hydraulic capacity. The lift capacity of the unit is limited by its stability, the lifting capability of the hydraulic elements, or the maximum permissible lifting capacity of the load hook.

In accordance with the harmonised European Standard EN 474-5, hydraulic excavators used for lifting operations must be equipped with pipe fracture safety valves, an overload warning device, a load hook and a lift capacity chart.

LH 30 C LC – Attachment GA10

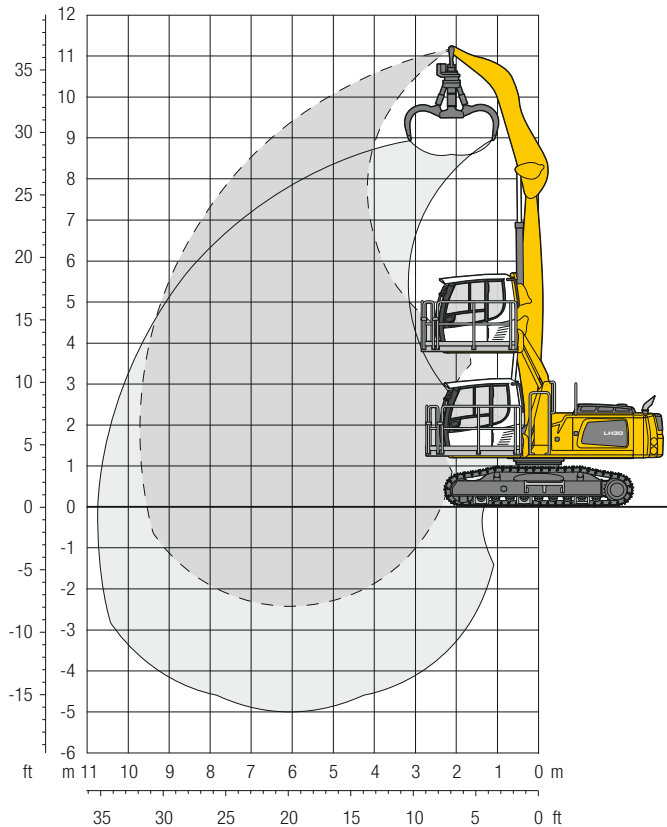

Operating Weight and Ground Pressure

The operating weight includes the basic machine with hydr. cab elevation, straight boom 5.80 m, angled stick 4.00 m and grab GM 65/0.60 m³ semi-closed tines.

Weight	28,600 kg
Pad width	600 mm
Ground pressure	on request

Dimensions

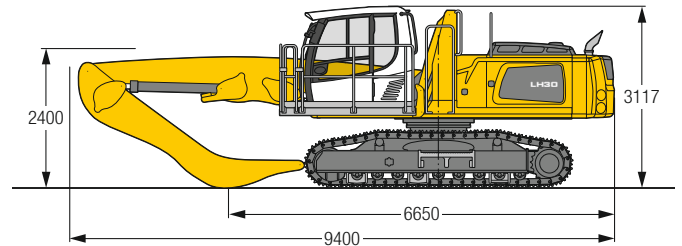

m	Undercarriage	3.0 m		4.5 m		6.0 m		7.5 m		9.0 m		10.5 m		12.0 m		13.5 m		15.0 m		m		
		LC	LC	LC	LC	LC	LC	LC	LC	LC	LC	LC	LC	LC	LC	LC	LC	LC	LC	LC	LC	LC
10.5	LC	10.9*	10.9*																	8.4*	8.4*	4.1
9.0	LC			10.5*	10.5*	7.8	7.9*													6.4*	6.4*	6.4
7.5	LC			10.5*	10.5*	7.9	8.9*	5.5	7.2*											5.1	5.8*	7.8
6.0	LC			10.9*	10.9*	7.8	9.1*	5.5	7.8*											4.3	5.5*	8.8
4.5	LC	13.5*	13.5*	11.7	11.9*	7.6	9.5*	5.4	7.9*	4.1	6.2									3.9	5.4*	9.3
3.0	LC	20.1*	20.1*	11.0	13.2*	7.2	10.0*	5.3	8.0*	4.0	6.2									3.7	5.5*	9.7
1.5	LC	5.0*	5.0*	10.3	13.9*	6.9	10.2*	5.1	7.9	4.0	6.1									3.6	5.2*	9.7
0	LC	4.9*	4.9*	9.9	13.1*	6.7	9.7*	5.0	7.4*	3.9	5.4*									3.6	4.5*	9.6
-1.5	LC			9.8	10.7*	6.6	8.3*	4.9	6.2*											4.1	4.5*	8.7

Height Can be slewed through 360° In longitudinal position of undercarriage Max. reach * Limited by hydr. capacity

The lift capacities on the stick end without attachment are stated in metric tons (t) and can be slewed through 360° on a firm, level supporting surface. Capacities are valid for 600 mm wide triple grouser pads. Indicated loads based on the ISO 10567 standard and do not exceed 75% of tipping or 87% of hydraulic capacity. The lift capacity of the unit is limited by its stability, the lifting capability of the hydraulic elements, or the maximum permissible lifting capacity of the load hook.

In accordance with the harmonised European Standard EN 474-5, hydraulic excavators used for lifting operations must be equipped with pipe fracture safety valves, an overload warning device, a load hook and a lift capacity chart.

LH 30 C EW – Attachment GA12

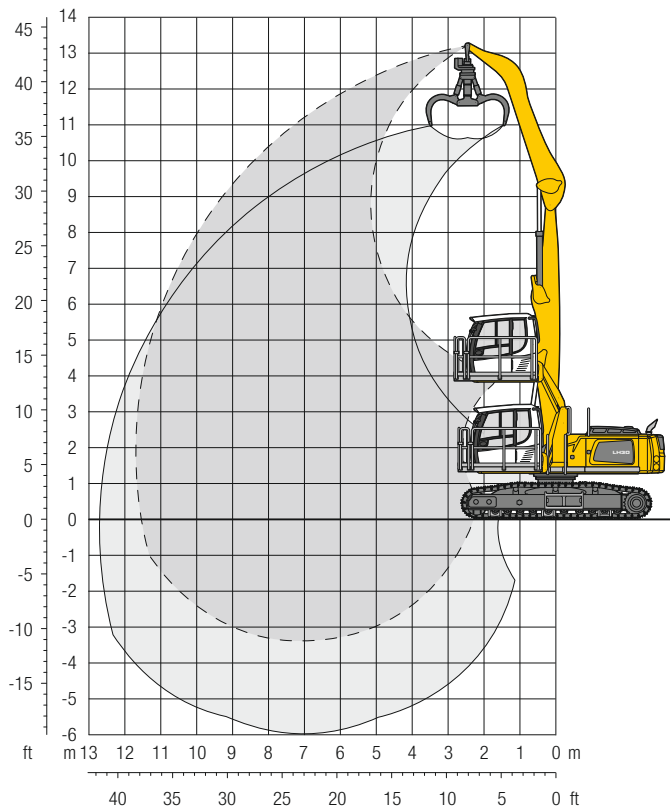

Operating Weight and Ground Pressure

The operating weight includes the basic machine with hydr. cab elevation, straight boom 6.80 m, angled stick 5.00 m and grab GM 65/0.60 m³ semi-closed tines.

Weight	30,600 kg
Pad width	600 mm
Ground pressure	on request

Dimensions

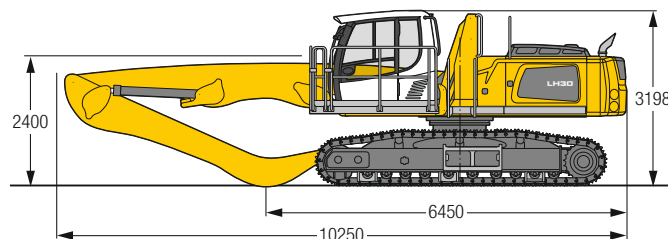

m	Undercarriage	3.0 m		4.5 m		6.0 m		7.5 m		9.0 m		10.5 m		12.0 m		13.5 m		15.0 m		m		
		Can be slewed through 360°	In longitudinal position of undercarriage	Can be slewed through 360°	In longitudinal position of undercarriage	Can be slewed through 360°	In longitudinal position of undercarriage	Can be slewed through 360°	In longitudinal position of undercarriage	Can be slewed through 360°	In longitudinal position of undercarriage	Can be slewed through 360°	In longitudinal position of undercarriage	Can be slewed through 360°	In longitudinal position of undercarriage	Can be slewed through 360°	In longitudinal position of undercarriage	Can be slewed through 360°	In longitudinal position of undercarriage	Can be slewed through 360°	In longitudinal position of undercarriage	
15.0	EW																					
13.5	EW																					
12.0	EW			8.2*	8.2*															6.2*	6.2*	5.7
10.5	EW					8.0*	8.0*	5.9*	5.9*											5.1*	5.1*	7.8
9.0	EW					7.9*	7.9*	7.0*	7.0*	5.4*	5.4*									4.6*	4.6*	9.2
7.5	EW					8.0*	8.0*	6.9*	6.9*	6.1*	6.1*									4.3*	4.3*	10.2
6.0	EW			9.9*	9.9*	8.3*	8.3*	7.1*	7.1*	6.2*	6.2*	5.1	5.3*							4.2*	4.2*	10.9
4.5	EW	9.5*	9.5*	11.3*	11.3*	8.9*	8.9*	7.3*	7.3*	6.2*	6.2*	5.1	5.3*							4.2*	4.2*	11.4
3.0	EW	19.5*	19.5*	12.6*	12.6*	9.4*	9.4*	7.6*	7.6*	6.3*	6.3*	5.0	5.2*							4.2	4.3*	11.7
1.5	EW	2.4*	2.4*	13.2*	13.2*	9.7*	9.7*	7.6*	7.6*	6.1	6.2*	4.9	5.0*							3.9*	3.9*	11.7
0	EW	2.7*	2.7*	9.3*	9.3*	9.4*	9.4*	7.3*	7.3*	5.8*	5.8*	4.5*	4.5*							3.4*	3.4*	11.5
-1.5	EW			8.6*	8.6*	8.4*	8.4*	6.6*	6.6*	5.2*	5.2*	3.7*	3.7*							3.1*	3.1*	11.0
-3.0	EW					6.6*	6.6*	5.3*	5.3*	4.0*	4.0*									3.9*	3.9*	9.1

Height **Can be slewed through 360°** **In longitudinal position of undercarriage** **Max. reach** * **Limited by hydr. capacity**

The lift capacities on the stick end without attachment are stated in metric tons (t) and can be slewed through 360° on a firm, level supporting surface. Capacities are valid for 600 mm wide triple grouser pads. Indicated loads based on the ISO 10567 standard and do not exceed 75% of tipping or 87% of hydraulic capacity. The lift capacity of the unit is limited by its stability, the lifting capability of the hydraulic elements, or the maximum permissible lifting capacity of the load hook.

In accordance with the harmonised European Standard EN 474-5, hydraulic excavators used for lifting operations must be equipped with pipe fracture safety valves, an overload warning device, a load hook and a lift capacity chart.

LH 30 C EW – Attachment GA14

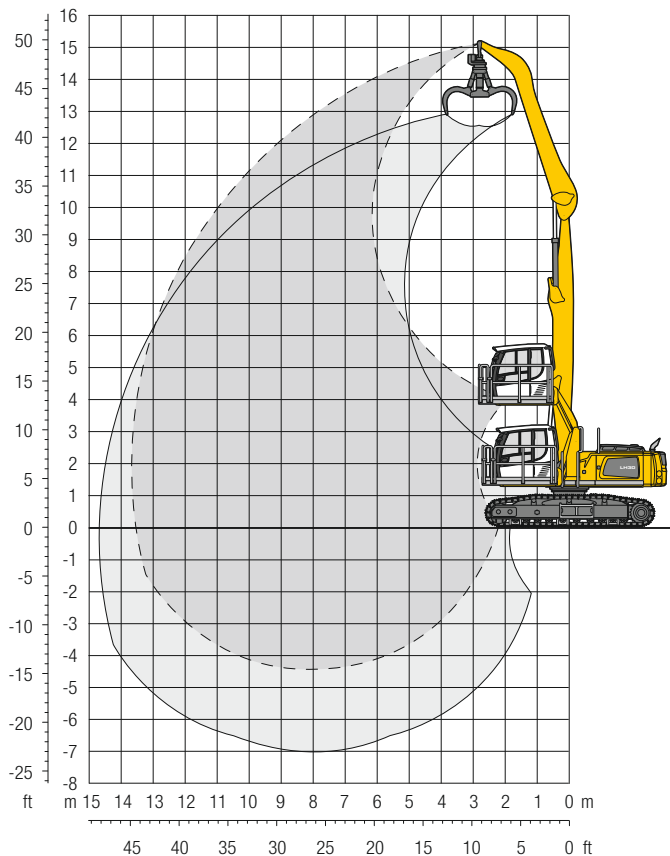

Operating Weight and Ground Pressure

The operating weight includes the basic machine with hydr. cab elevation, straight boom 7.80 m, angled stick 6.00 m and grab GM 65/0.60 m³ semi-closed tines.

Weight	31,000 kg
Pad width	600 mm
Ground pressure	on request

Dimensions

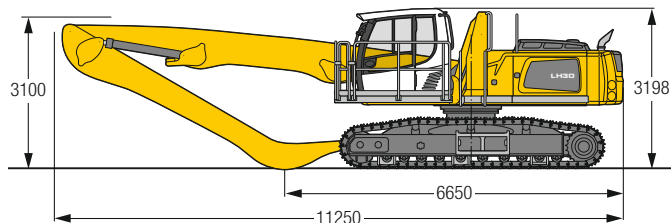

m	Undercarriage	3.0 m		4.5 m		6.0 m		7.5 m		9.0 m		10.5 m		12.0 m		13.5 m		15.0 m		m			
		8.2*	8.2*			6.4*	6.4*			6.3*	6.3*	4.4*	4.4*										
15.0	EW																				7.8*	7.8*	3.3
13.5	EW																				5.0*	5.0*	7.0
12.0	EW																				4.2*	4.2*	9.1
10.5	EW																				3.8*	3.8*	10.6
9.0	EW																				3.6*	3.6*	11.7
7.5	EW																				3.5*	3.5*	12.5
6.0	EW																				3.4*	3.4*	13.0
4.5	EW																				3.3	3.4*	13.4
3.0	EW																				3.2	3.2*	13.6
1.5	EW																				2.9*	2.9*	13.7
0	EW																				2.6*	2.6*	13.5
-1.5	EW																				2.2*	2.2*	13.2
-3.0	EW																				2.5*	2.5*	12.0

Height **Can be slewed through 360°** **In longitudinal position of undercarriage** **Max. reach** * **Limited by hydr. capacity**

The lift capacities on the stick end without attachment are stated in metric tons (t) and can be slewed through 360° on a firm, level supporting surface. Capacities are valid for 600 mm wide triple grouser pads. Indicated loads based on the ISO 10567 standard and do not exceed 75% of tipping or 87% of hydraulic capacity. The lift capacity of the unit is limited by its stability, the lifting capability of the hydraulic elements, or the maximum permissible lifting capacity of the load hook.

In accordance with the harmonised European Standard EN 474-5, hydraulic excavators used for lifting operations must be equipped with pipe fracture safety valves, an overload warning device, a load hook and a lift capacity chart.

LH 30 C EW – Attachment GK12

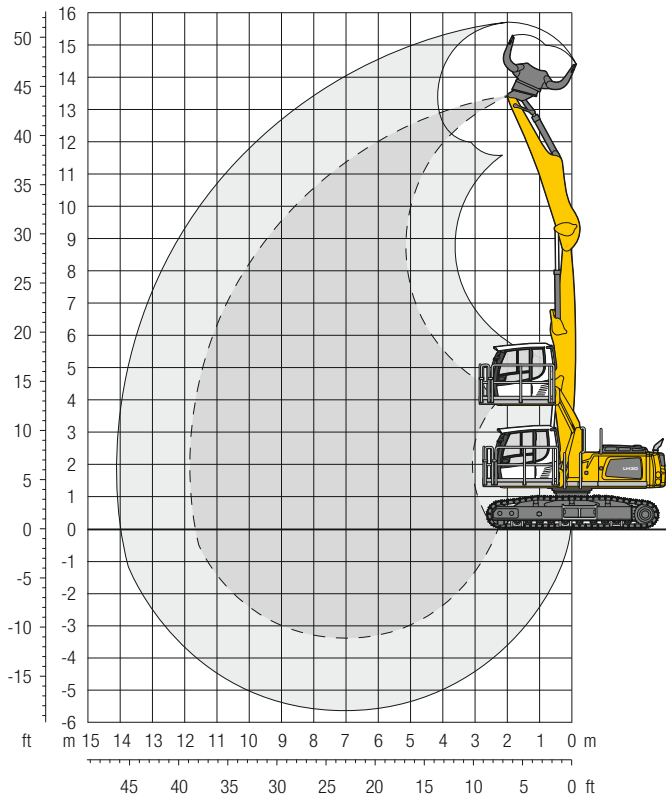

Operating Weight and Ground Pressure

The operating weight includes the basic machine with hydr. cab elevation, straight boom 6.80 m, stick with tipping kinematics 5.00 m and sorting grab SG 30B/0.85 m³ tines.

Weight	31,600 kg
Pad width	600 mm
Ground pressure	on request

Dimensions

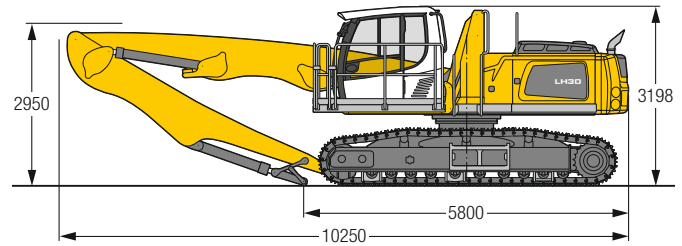

m	Undercarriage	3.0 m		4.5 m		6.0 m		7.5 m		9.0 m		10.5 m		12.0 m		13.5 m		15.0 m		m		
		EW	EW	EW	EW	EW	EW	EW	EW	EW	EW	EW	EW	EW	EW	EW	EW	EW	EW	EW	EW	EW
12.0	EW			8.8*	8.8*															6.3*	6.3*	6.0
10.5	EW					7.9*	7.9*	6.5*	6.5*											5.0*	5.0*	8.1
9.0	EW					7.6*	7.6*	6.6*	6.6*	5.9*	5.9*									4.4*	4.4*	9.4
7.5	EW					7.7*	7.7*	6.6*	6.6*	5.8*	5.8*									4.1*	4.1*	10.4
6.0	EW			8.8*	8.8*	8.0*	8.0*	6.8*	6.8*	5.8*	5.8*	4.9	5.0*							4.0*	4.0*	11.1
4.5	EW	6.8*	6.8*	10.6*	10.6*	8.6*	8.6*	7.0*	7.0*	5.9*	5.9*	4.8	5.0*							3.9*	3.9*	11.6
3.0	EW	18.0*	18.0*	12.3*	12.3*	9.1*	9.1*	7.2*	7.2*	5.9*	5.9*	4.7	4.9*							3.7*	3.7*	11.8
1.5	EW			12.9*	12.9*	9.3*	9.3*	7.3*	7.3*	5.8*	5.8*	4.6	4.7*							3.3*	3.3*	11.8
0	EW	1.5*	1.5*	7.5*	7.5*	9.0*	9.0*	7.0*	7.0*	5.5*	5.5*	4.2*	4.2*							2.8*	2.8*	11.7
-1.5	EW			7.4*	7.4*	8.0*	8.0*	6.2*	6.2*	4.8*	4.8*	3.4*	3.4*							2.8*	2.8*	11.0
-3.0	EW					6.3*	6.3*	4.9*	4.9*	3.6*	3.6*									3.5*	3.5*	9.1

Height Can be slewed through 360° In longitudinal position of undercarriage Max. reach * Limited by hydr. capacity

The lift capacities on the stick end without attachment are stated in metric tons (t) and can be slewed through 360° on a firm, level supporting surface. Capacities are valid for 600 mm wide triple grouser pads. Indicated loads based on the ISO 10567 standard and do not exceed 75% of tipping or 87% of hydraulic capacity. The lift capacity of the unit is limited by its stability, the lifting capability of the hydraulic elements, or the maximum permissible lifting capacity of the load hook.

In accordance with the harmonised European Standard EN 474-5, hydraulic excavators used for lifting operations must be equipped with pipe fracture safety valves, an overload warning device, a load hook and a lift capacity chart.

Working Tools

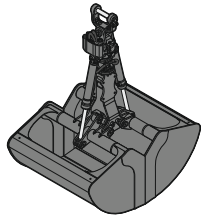

Shells for Loose Material

Shells for loose material with cutting edge (without teeth)

Grab model GM 20C

Width of shells	mm	1,190	1,500	1,750	2,000	2,250	2,500
Capacity	m ³	1.20	1.50	1.75	2.00	2.25	2.50
Weight	kg	1,495	1,625	1,730	1,830	1,935	2,065

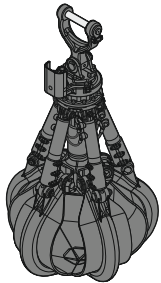

Multi-Tine Grab

open

semi-closed

closed

Grab model GM 64 (4 tines)

Capacity	m ³	0.40	0.60	0.40	0.60	0.40	0.60
Weight	kg	800	910	940	1,060	1,100	1,265

Grab model GM 65 (5 tines)

Capacity	m ³	0.40	0.60	0.40	0.60	0.40	0.60
Weight	kg	1,175	1,310	1,350	1,490	1,365	1,605

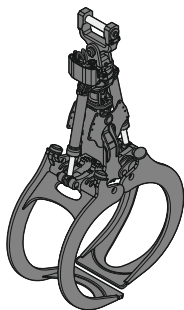

Wood Grab

Grab model GM 20B round-shaped (complete overlapping, vertical cylinders)

Size	m ²	1.00	1.30	1.50	1.70	1.90
Cutting width	mm	810	810	810	810	810
Height of grab, closed	mm	2,572	2,675	2,720	2,812	2,897
Weight	kg	1,545	1,575	1,595	1,625	1,760

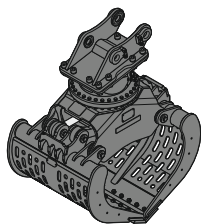

Sorting Grab

ribbed

perforated

ribbed

perforated

ribbed

perforated

Grab model SG 30B

Width of shells	mm	1,000	1,000	1,200	1,200	1,400	1,400
Capacity	m ³	0.75	0.85	0.90	1.00	1.05	1.15
Max. closing force	kN	80	80	80	80	80	80
Weight incl. adapter plate SWA	kg	1,765	1,685	1,875	1,760	1,980	1,835

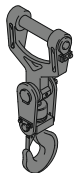

Load Hook with Suspension

Max. load	t	12.5
Height with suspension	mm	930
Weight	kg	135

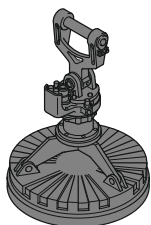



Magnet Devices / Lifting Magnets

Generator	kW	13/17	13/17
Electromagnets with suspension			
Power	kW	8.8	10
Diameter of magnet	mm	1,250	1,350
Weight	kg	1,310*	1,700*

* only magnet plate

Equipment

 Undercarriage	30 M	35 M	30 C
4-wheel steering		+	
Trailer coupling	+	+	
Track pads, variants			+
Individual control outriggers	+	+	
Shuttle axle lock, automatic	•	•	
Outrigger monitoring system	+	+	
Dozer blade	+	+	
Tyres, variants	+	+	
Protection for travel drive	+	+	
Protection for piston rods, outriggers	+	+	
Two lockable storage compartments	•	•	
Undercarriage, variants			+

 Uppercarriage	30 M	35 M	30 C
Uppercarriage rear light, 2 pieces, LED	+	+	+
Uppercarriage right side light, 1 piece, LED	•	•	•
Refuelling system with filling pump	+	+	+
Railing on uppercarriage	+	+	+
Generator	+	+	+
Main battery switch for electrical system	•	•	•
Warning beacon on uppercarriage, LED	+	+	+
Protection for headlights	+	+	+
Protection for rear lights	+	+	+
Tool equipment, extended	+	+	+

 Hydraulic System	30 M	35 M	30 C
Electronic pump regulation	•	•	•
Liebherr hydraulic oil from -20 °C to +40 °C	•	•	•
Liebherr hydraulic oil, biologically degradable	+	+	+
Magnetic rod in hydraulic tank	•	•	•
Bypass filter	+	+	+
Preheating hydraulic oil	+	+	+

 Engine	30 M	35 M	30 C
Fuel anti-theft device	+	+	+
Air pre-filter with dust discharge	+	+	+
Automatic engine shut-down (time adjustable)	+	+	+
Preheating fuel	+	+	+
Preheating coolant	+	+	+
Preheating engine oil *	+	+	+

 Cooling System	30 M	35 M	30 C
Radiator, large-mesh, for dust-intensive operation	•	•	•
Reversible fan drive, fully automatic	+	+	+
Protective grid in front of cooler intake	•	•	•



Operator's Cab

	30 M	35 M	30 C
Stabilizer, proportional control on left joystick	•	•	
Cab lights rear, halogen	+	+	+
Cab lights rear, LED	+	+	+
Cab lights front, halogen	+	+	+
Cab lights front, halogen (under rain cover)	•	•	•
Cab lights front, LED	+	+	+
Cab lights front, LED (under rain cover)	+	+	+
Left arm console, folding	•	•	•
Armrest adjustable	•	•	•
Slewing gear brake Comfort, button on the left or right joystick	+	+	+
Operator's seat Comfort	•	•	•
Operator's seat Premium	+	+	+
Driving alarm			
(acoustic signal is emitted during travel, can be switched ON/OFF)	+	+	+
Fire extinguisher	+	+	+
Footrest	+	+	+
Horn, button on left joystick	•	•	•
Joystick steering (max. 12 km/h)	•	•	
Joystick and wheel steering (slim version)	+	+	
Cab elevation, hydraulic (LHC)	•	•	•
Cab elevation, rigid (LFC)	+	+	+
Automatic air conditioning	•	•	•
Wheel steering (slim version)	+	+	
LiDAT, vehicle fleet management	•	•	•
Proportional control	•	•	•
Radio Comfort, control via display with handsfree set	+	+	+
Preparation for radio installation	•	•	•
Back-up alarm			
(acoustic signal is emitted traveling backward, can not be switched off)	+	+	
Warning beacon on cab, LED	+	+	+
Windows made from impact-resistant laminated safety glass	+	+	+
Windscreen wiper, roof	+	+	+
Windshield wiper, entire windscreen	•	•	•
Top guard	+	+	+
Front guard, adjustable	+	+	+
Sun visor	+	+	+
Flashing light (xenon)	+	+	+



Attachment

	30 M	35 M	30 C
Boom lights, 2 pieces, halogen	•	•	•
Boom lights, 2 pieces, LED	+	+	+
Stick lights, 2 pieces, halogen	•	•	•
Stick lights, 2 pieces, LED	+	+	+
Filter system for working tool	+	+	+
Height limitation and stick shutoff, electronically	+	+	+
Boom cylinder cushioning	+	+	+
Stick camera (with separate monitor), bottom side, with protection	+	+	+
Liebherr multi coupling system	+	+	+
Liebherr quick coupler, hydraulic	+	+	+
Pipe fracture safety valves hoist cylinders	•	•	•
Pipe fracture safety valves stick cylinders	•	•	•
Quick coupling system LIKUFIX	+	+	+
Quick coupling system MH 40B	+	+	+
Protection for piston rods, hoist cylinder	+	+	+
Overload warning device	+	+	+



Complete Machine

	30 M	35 M	30 C
Lubrication			
Lubrication undercarriage, manually – decentralised (grease points)	•	•	
Lubrication undercarriage, manually – centralised (one grease point)	+	+	
Central lubrication system for uppercarriage and attachment, automatically	•	•	•
Central lubrication system for undercarriage, automatically	+	+	
Central lubrication system, extension for tool attachment	+	+	+
Special coating			
Special coating, variants	+	+	+
Monitoring			
Rear view monitoring with camera	•	•	•
Side view monitoring with camera	•	•	•

• = Standard, + = Option

* = country-dependent

Options and / or special attachments, supplied by vendors other than Liebherr, are only to be installed with the knowledge and approval of Liebherr in order to retain warranty.

The Liebherr Group of Companies



Wide Product Range

The Liebherr Group is one of the largest construction equipment manufacturers in the world. Liebherr's high-value products and services enjoy a high reputation in many other fields. The wide range includes domestic appliances, aerospace and transportation systems, machine tools and maritime cranes.

Exceptional Customer Benefit

Every product line provides a complete range of models in many different versions. With both their technical excellence and acknowledged quality, Liebherr products offer a maximum of customer benefits in practical applications.

State-of-the-art Technology

To provide consistent, top quality products, Liebherr attaches great importance to each product area, its components and core technologies. Important modules and components are developed and manufactured in-house, for instance the entire drive and control technology for construction equipment.

Worldwide and Independent

Hans Liebherr founded the Liebherr family company in 1949. Since that time, the enterprise has steadily grown to a group of more than 130 companies with over 41,000 employees located on all continents. The corporate headquarters of the Group is Liebherr-International AG in Bulle, Switzerland. The Liebherr family is the sole owner of the company.

www.liebherr.com

Liebherr-Hydraulikbagger GmbH

Liebherrstraße 12, D-88457 Kirchdorf/Iller
☎ +49 7354 80-0, Fax +49 7354 80-7294
www.liebherr.com, E-Mail: info.lhb@liebherr.com
www.facebook.com/LiebherrConstruction