

Product Information Log Loader

LH 60 M Timber

Litronic®

Operating Weight

42,600 – 45,500 kg *

Engine

200 kW / 272 HP

Stage V

Stage IIIA (equivalent)

*Without attachment



LIEBHERR

Performance

Power Plus Speed –
Redefined Performance

Economy

Good Investment –
Savings for Long-term



Reliability

Durability and Sustainability –
Quality Down to the Last Detail

Comfort

Perfection at a Glance –
When Technology is Comfortable

Maintainability

Efficiency Bonus –
Even with Maintenance and Service



Well Thought Out to the Last Detail





Twin Engine Travel Drive

- Higher driving performance thanks to greater pulling power at max. speed
- More efficient driving without gear shifting for fluid working operation
- Powerful, robust, reliable and quiet



Rigid Cab Elevation LFC 120

- New, clever, space-saving access system with integrated treads and 10° inclination for easy access and more safety



Mudguards

- Robust construction of hot-dip galvanised steel for a long service life in tough timber applications
- Integrated rubber flaps provide maximum splash protection when driving forward or in reverse

Convincing in Operation



Performance

Enhanced Driving Performance

With an engine output of 200 kW, the system has maximum torque for high speeds at its disposal. The stepless drivetrain also maintains the speed at a constant level in the optimum range for maximum acceleration with consistently high pulling power. In this way, a high level of driving performance can be consistently drawn upon even on gradients.

Convincing Dynamics

The combination of 200 kW engine output and a high pump delivery rate guarantees maximum acceleration and the highest speed of the working movements.

4-Wheel Steering

The standard 4-wheel steering provides great agility and manoeuvrability of the log loader, even in the tight space of a timber yard. Furthermore, the 4-wheel steering increases driving stability and improves the driving in one lane.

Economy

LSC Hydraulic System

The cleverly engineered machine control system assures optimum adaptation of the hydraulics to the respective deployment scenario. Here, the new 2-circuit Liebherr-Synchron-Comfort-system (LSC) with LUDV technology (flow distribution independent of load pressure) provides optimum distribution of the pump delivery rate with superimposed movements a less fuel consumption compared with the previous model. Speed and strength are there when they are needed.

Liebherr-Power Efficiency (LPE)

LPE optimises the interaction of the drive components in terms of efficiency and enables machine operation in the area of the lowest specific fuel use for less consumption and greater efficiency with the same performance.

Reliability

Quality and Competence

Our experience, understanding of customer needs and the technical implementation of these findings guarantee the success of the product. For decades, Liebherr has been inspirational with its knowledge of production and system solutions. Key components such as the diesel engine, electronic components, slew ring, swivel drive and hydraulic cylinders are developed and produced by Liebherr itself. The great depth of in-house manufacturing guarantees maximum quality and ensures that components are optimally configured to each other.

Protective Devices

Especially in tough timber application the material handlers are used heavily. The optional protective devices extend the component service life and guarantee high machine availability with maximum safety for people and machine.

Intelligent Self Diagnostics

The clever control electronics permanently monitor the vital functions of the machine to guarantee a high level of machine availability. Components which are critical for safety are designed with redundancy to guarantee maximum safety.

Comfort

Proportional Control

In timber yards, where space is tight, precision and fine control are especially important. The 4-way mini-joystick with its proportional control make for efficient use of the machine. Functions such as support and joystick steering are controlled via the two mini-joysticks. Clearing operations can be carried out in this way with ease and precision using both hands on the joystick.

Slewing Gear Brake Comfort

The standard slewing gear brake comfort control allows the selection between the mode manual, semiautomatic and automatic.

This standard slewing gear brake in the manual mode can be opened and closed with the button on the joystick.

In the semiautomatic mode the slewing gear brake can also be closed manually but automatically opened again when the uppercarriage is moved via the joystick control.

The automatic mode allows the slewing gear brake to be closed automatically when the predefined time, set by the operator, has passed and the uppercarriage has stopped moving. It can be opened automatically as soon as the uppercarriage is moved via the joystick control.

By opening and closing the slewing gear brake automatically the operator can work faster and more safely with less effort.

Maintainability

Service-based Machine Design

The service-based machine design guarantees short servicing times, thus minimizing maintenance costs due to the time it saves. All the maintenance points are easily accessible from the ground and easy to reach due to the large, wide-opening service doors. The enhanced service concept places the maintenance points close to each other and reduces their number to a minimum. This means that service work can be completed even more quickly and efficiently.

SCRFilter for stage V

The SCR filter system includes a DOC catalyst, an SCR catalyst and an SCR-coated particulate filter. The DOC catalyst requires no maintenance and the coated particulate filter is regenerated passively ensuring that the system is reliable and easy to use. The maintenance intervals can be extended to more than 4,500 operating hours.

Technical Data



Diesel Engine

Rating per ISO 9249	200 kW (272 HP) at 1,800 RPM
Model	Liebherr D944
Type	4 cylinder in-line
Bore/Stroke	130/150 mm
Displacement	8.0 l
Engine operation	4-stroke diesel Common-Rail turbo-charged and after-cooled reduced emissions
Air cleaner	dry-type air cleaner with pre-cleaner, primary and safety elements
Engine idling	sensor controlled
Electrical system	
Voltage	24 V
Batteries	2 x 180 Ah/12 V
Alternator	three-phase current 28 V/140 A
Stage V	
Harmful emissions values	according to regulation (EU) 2016/1628
Emission control	Liebherr-SCRFilter technology
Fuel tank	518 l
Urea tank	65 l
Power Band	
Harmful emissions values	in accordance with ECE-R.96 (Stage IIIA equivalent)
Category	H
Fuel tank	518 l



Cooling System

Diesel engine	water-cooled compact cooling system consisting cooling unit for water, hydraulic oil and charge air with stepless thermostatically controlled fan
----------------------	--



Hydraulic Controls

Power distribution	via control valves with integrated safety valves, simultaneous actuation of chassis and equipment. Swing drive in separate closed circuit
Servo circuit	
Equipment and swing	with electro-hydraulic pilot control and proportional joystick levers
Chassis	electroproportional via foot pedal
Additional functions	via switch or electroproportional foot pedals
Proportional control	proportionally acting transmitters on the joysticks for additional hydraulic functions



Hydraulic System

Hydraulic pump	for equipment and travel drive	2 Liebherr axial piston variable displacement pumps (double construction)
Max. flow		2 x 302 l/min.
Max. pressure for swing drive		350 bar
		reversible axial piston variable displacement pump, closed-loop circuit
Max. flow		199 l/min.
Max. pressure		370 bar
Hydraulic pump regulation and control		2 circuit Liebherr-Synchron-Comfort-system (LSC) with electronic engine speed sensing regulation, pressure and flow compensation, automatic oil flow optimizer
Hydraulic tank		265 l
Hydraulic system		890 l
Hydraulic oil filter		2 main return filters with integrated partial micro filtration (5 µm)
MODE selection		adjustment of engine and hydraulic performance via a mode pre-selector to match application, e.g. for especially economical and environmentally friendly operation or for maximum material handling and heavy-duty jobs
S (Sensitive)		mode for precision work and lifting through very sensitive movements
E (Eco)		mode for especially economical and environmentally friendly operation
P (Power)		mode for high performance with low fuel consumption
P+ (Power-Plus)		mode for highest performance and for very heavy duty applications, suitable for continuous operation
Engine speed and performance setting		stepless alignment of engine output and hydraulic power via engine speed
Option		Tool Control: 20 preadjustable pump flows and pressures for add-on attachments



Swing Drive

Drive	Liebherr axial piston motor in a closed system, Liebherr planetary reduction gear
Swing ring	Liebherr, sealed race ball bearing swing ring, internal teeth
Swing speed	0 – 8.0 RPM stepless
Swing torque	118 kNm
Holding brake	wet multi-disc (spring applied, pressure released)
Operation holding brake	slewing gear brake Comfort



Operator's Cab

Cab	TOPS safety cab structure (tip-over protection) with individual windscreens or featuring a slide-in subpart under the ceiling, work headlights integrated in the ceiling, a door with a sliding window (can be opened on both sides), large stowing and depositing possibilities, shock-absorbing suspension, sounddamping insulating, tinted laminated safety glass, separate shades for the sunroof window and windscreen
Operator's seat Comfort	air cushioned operator's seat with 3D-adjustable armrests, headrest, lap belt, seat heater, adjustable seat cushion inclination and length, lockable horizontal suspension, automatic weight adjustment, adjustable suspension stiffness, pneumatic lumbar vertebrae support and passive seat climatisation with active coal
Operator's seat Premium (Option)	in addition to operator's seat comfort: active electronic weight adjustment (automatic re-adjustment), pneumatic low frequency suspension and active seat climatisation with active coal and ventilator
Control system	joysticks with control consoles and swivel seat, folding left control console
Operation and displays	large high-resolution operating unit, self-explanatory, colour display with touchscreen, video-compatible, numerous setting, control and monitoring options, e.g. air conditioning control, fuel consumption, machine and attachment parameters
Air-conditioning	automatic air-conditioning, recirculated air function, fast de-icing and demisting at the press of a button, air vents can be operated via a menu; recirculated air and fresh air filters can be easily replaced and are accessible from the outside; heating-cooling unit, designed for extreme outside temperatures, sensors for solar radiation, inside and outside temperatures
Refrigerant	R134a
Global warming potential	1,430
Quantity at 25 °C*	1,400 – 2,000 g
CO ₂ equivalent*	2.002 – 2.86 t
Vibration emission**	
Hand/arm vibrations	< 2.5 m/s ²
Whole-body vibrations	< 0.5 m/s ²
Measuring inaccuracy	according with standard EN 12096:1997

Undercarriage

Drive	transfer gearbox with 2 Liebherr axial piston motor and functional brake valve on both sides
Travel speed	
Joystick steering	0 – 10.0 km/h stepless (creeper speed) 0 – 20.0 km/h stepless
Driving operation	automotive driving using accelerator pedal, cruise control function: storage of variable accelerator pedal positions
Axes	70 t drive axles; manual or automatic hydraulically controlled front axle oscillation lock
Four wheel steering	standard
Steering reversal control	standard
Service brake	two circuit travel brake system with accumulator; disc brake
Holding brake	disc brake
Stabilization	stabilizer blade rear
Option	stabilizer blade rear and front



Equipment

Type	high-strength steel plates at highly stressed points for the toughest requirements. Complex and stable mountings of equipment and cylinders
Hydraulic cylinders	Liebherr cylinders with special seal system as well as shock absorption
Bearings	sealed, low maintenance



Complete Machine

Lubrication	Liebherr central lubrication system for upper-carriage and equipment, automatically
Option	Liebherr central lubrication system for under-carriage, automatically
Steps system	safe and durable access system with anti-slip steps main components hot-galvanised
Noise emission	
ISO 6396	L _{PA} (inside cab) = 70 dB(A) (Stage V)
2000/14/EC	L _{WA} (surround noise) = 103 dB(A) (Stage V)
ISO 6396	L _{PA} (inside cab) = not specified (Power Band)
2000/14/EC	L _{WA} (surround noise) = not specified (Power Band)

* depending on configuration

** for risk assessment according to 2002/44/EC see ISO/TR 25398:2006

Dimensions

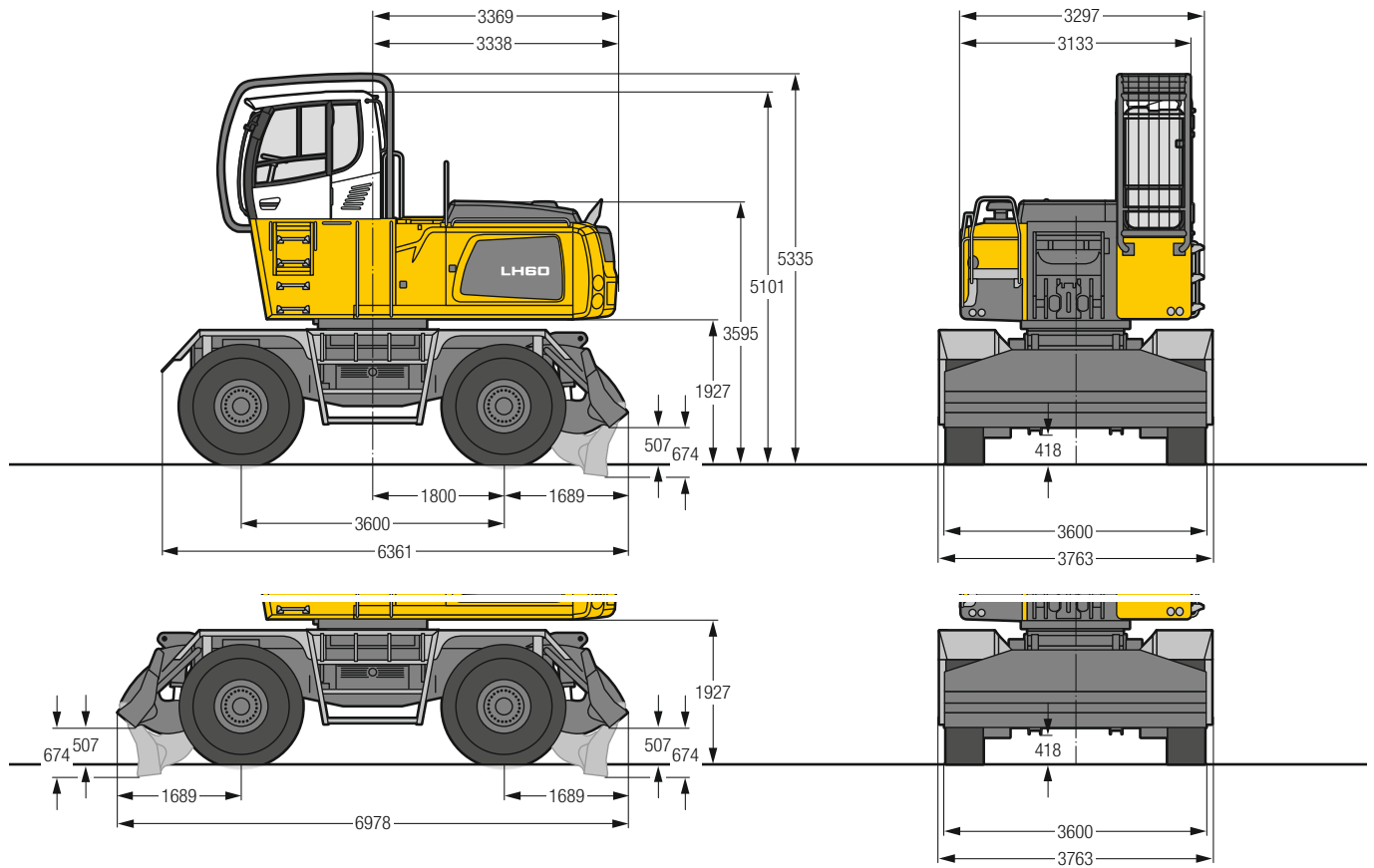

Turn Radius

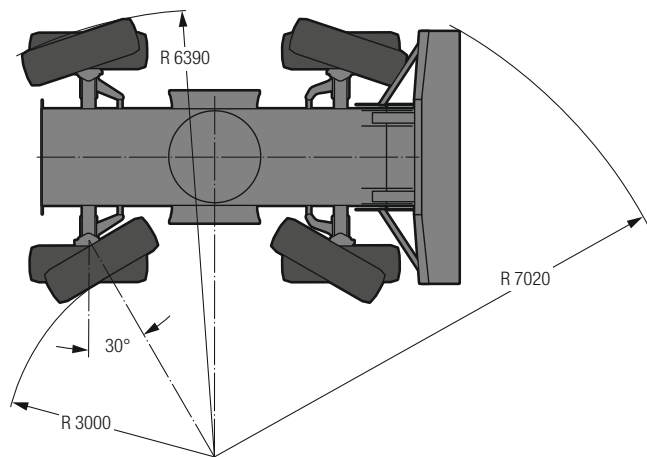

Tyres 18.00-25

Choice of Cab Elevation

Cab Elevation LFC (Rigid Elevation)

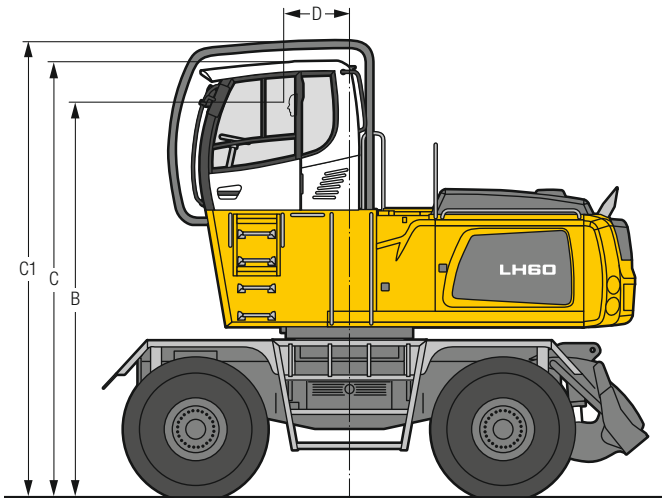

Increase type	LFC 120
Height	1,200 mm
B	4,627 mm
C	5,101 mm
C1	5,335 mm
D	770 mm

A rigid cab elevation has a fixed eye level height. For a lower transport height, the shell of the cab can be removed and replaced by a transport device. On this machine dimension C is 4,205 mm.

Cab Protection

Integral Guard

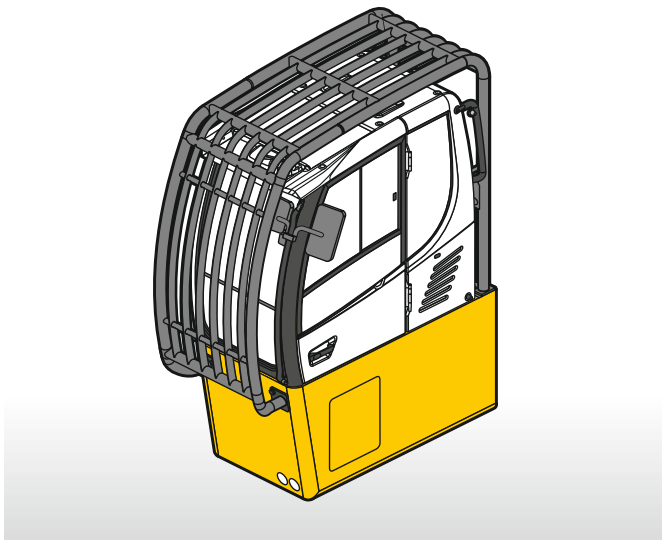

Equipment GA11

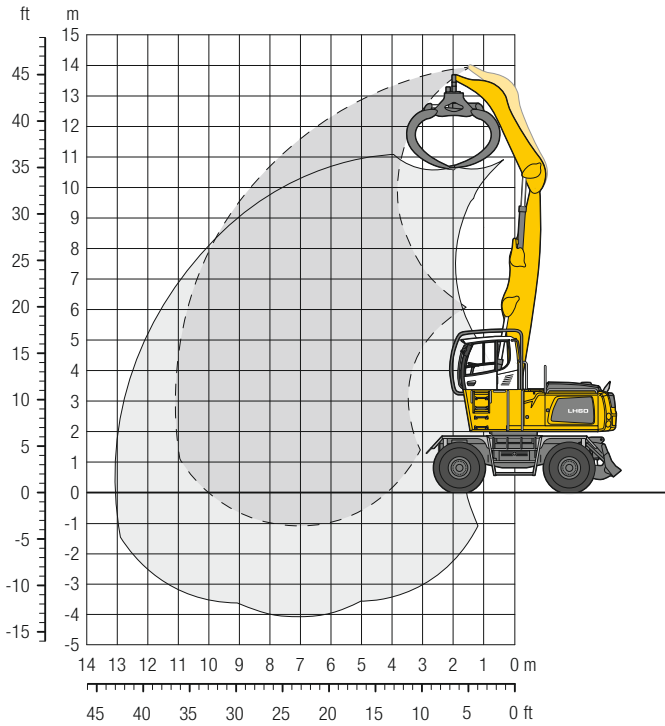

Operating Weight

The operating weight includes the basic machine with stabilizer blade, rigid cab elevation, 4 pneumatic tyres, straight boom 7.00 m, angled stick 4.50 m and wood grab GMH 50/3.20 m².

Weight	44,800 kg
--------	-----------

Dimensions

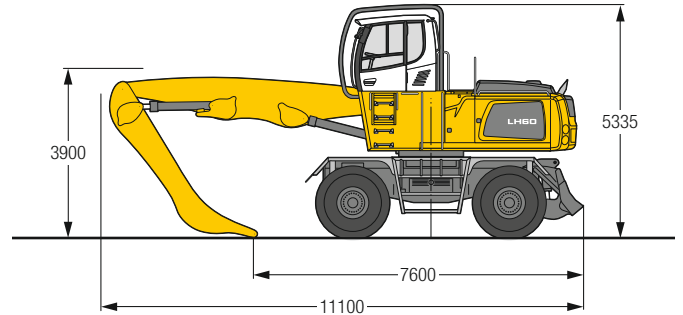

m	Undercarriage	3.0 m		4.5 m		6.0 m		7.5 m		9.0 m		10.5 m		13.5 m		m
		Stabilizers raised (drive operation)	Stabilizers raised	Stabilizers raised (drive operation)	Stabilizers raised	Stabilizers raised (drive operation)	Stabilizers raised	Stabilizers raised (drive operation)	Stabilizers raised	Stabilizers raised (drive operation)	Stabilizers raised	Stabilizers raised (drive operation)	Stabilizers raised	Stabilizers raised (drive operation)	Stabilizers raised	
13.5	Stabilizers raised (drive operation)	12.9*	12.9*											12.3*	12.3*	3.3
	Stabilizers raised	12.9*	12.9*											12.3*	12.3*	
	Stabilizer blade down	12.9*	12.9*											12.3*	12.3*	
12.0	Stabilizers raised (drive operation)			12.3*	12.3*	10.0*	10.0*							9.0*	9.0*	6.4
	Stabilizers raised			12.3*	12.3*	10.0*	10.0*							9.0*	9.0*	
	Stabilizer blade down			12.3*	12.3*	10.0*	10.0*							9.0*	9.0*	
10.5	Stabilizers raised (drive operation)			12.9*	12.9*	11.8	12.0*	8.2	9.7*					7.1	8.0*	8.1
	Stabilizers raised			12.9*	12.9*	12.0*	12.0*	9.7*	9.7*					8.0*	8.0*	
	Stabilizer blade down			12.9*	12.9*	12.0*	12.0*	9.7*	9.7*					8.0*	8.0*	
9.0	Stabilizers raised (drive operation)			13.4*	13.4*	11.7	13.2*	8.2	10.2	6.1	7.6			5.7	7.2	9.3
	Stabilizers raised			13.4*	13.4*	13.2*	13.2*	10.2	11.9*	7.6	8.6*			7.2	7.5*	
	Stabilizer blade down			13.4*	13.4*	13.2*	13.2*	10.7	11.9*	7.9	8.6*			7.5	7.5*	
7.5	Stabilizers raised (drive operation)			14.4*	14.4*	11.5	14.2*	8.1	10.1	6.0	7.6			5.0	6.2	10.1
	Stabilizers raised			14.4*	14.4*	14.2*	14.2*	10.1	12.2*	7.6	9.5			6.2	7.3*	
	Stabilizer blade down			14.4*	14.4*	14.2*	14.2*	10.6	12.2*	7.9	10.7*			6.5	7.3*	
6.0	Stabilizers raised (drive operation)	15.2*	15.2*	17.4	18.6*	11.0	14.0	7.8	9.8	5.9	7.4	4.6	5.9	4.5	5.7	10.7
	Stabilizers raised	15.2*	15.2*	18.6*	18.6*	13.8	15.1*	9.8	12.3	7.4	9.3	5.8	7.3	5.6	7.1	
	Stabilizer blade down	15.2*	15.2*	18.6*	18.6*	14.4	15.1*	10.3	12.6*	7.8	10.8*	6.1	8.3*	5.9	7.3*	
4.5	Stabilizers raised (drive operation)			16.1	21.2*	10.4	13.3	7.5	9.5	5.8	7.3	4.6	5.8	4.3	5.4	11.0
	Stabilizers raised			20.2	21.2*	13.0	16.0*	9.4	11.9	7.2	9.1	5.7	7.2	5.3	6.7	
	Stabilizer blade down			21.2*	21.2*	13.7	16.0*	9.9	13.0*	7.5	10.9*	6.0	9.2*	5.6	7.5*	
3.0	Stabilizers raised (drive operation)			14.9	19.9	9.8	12.7	7.2	9.2	5.6	7.1	4.5	5.7	4.1	5.3	11.1
	Stabilizers raised			18.6	21.9*	12.3	15.9	9.0	11.5	7.0	8.9	5.6	7.1	5.2	6.6	
	Stabilizer blade down			19.8	21.9*	13.0	16.6*	9.5	13.2*	7.3	10.9*	5.9	8.9*	5.4	7.8*	
1.5	Stabilizers raised (drive operation)			11.2*	11.2*	9.4	12.2	6.9	8.9	5.4	6.9	4.4	5.6	4.1	5.3	11.0
	Stabilizers raised			11.2*	11.2*	11.8	15.3	8.7	11.1	6.8	8.7	5.5	7.0	5.2	6.6	
	Stabilizer blade down			11.2*	11.2*	12.4	16.4*	9.1	13.0*	7.1	10.5*	5.8	8.3*	5.5	7.4*	
0	Stabilizers raised (drive operation)			11.1*	11.1*	9.2	12.0	6.8	8.8	5.3	6.8			4.6	5.9	10.1
	Stabilizers raised			11.1*	11.1*	11.5	15.0	8.5	10.9	6.7	8.6			5.8	7.4	
	Stabilizer blade down			11.1*	11.1*	12.1	15.1*	8.9	12.0*	7.0	9.6*			6.1	7.9*	

Height **Can be slewed through 360°** **In longitudinal position of undercarriage** **Max. reach** * Limited by hydr. capacity

The lift capacities on the stick end without attachment are stated in metric tons (t) and are valid on a firm, level supporting surface with blocked oscillating axle. These capacities can be slewed through 360° with the undercarriage in the transverse position. Capacities in the longitudinal position of the undercarriage (+/- 15°) are specified over the steering axle with the stabilizers raised and over the rigid axle with the stabilizers down. Indicated loads based on the ISO 10567 standard and do not exceed 75% (according to EN 474-5 in drive operation only 60%) of tipping or 87% of hydraulic capacity. The lift capacity of the unit is limited by its stability, the lifting capability of the hydraulic elements, or the maximum permissible lifting capacity of the load hook.

In accordance with the harmonised European Standard EN 474-5, hydraulic excavators used for lifting operations must be equipped with pipe fracture safety valves, an overload warning device, a load hook and a lift capacity chart.

Attachments

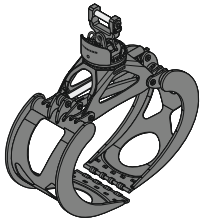

Wood Grab

Grab model GMH 50 round-shaped (overlapping, horizontal cylinders)

Size	m ²	2.50	2.50	2.80	3.20	3.60
Cutting width	mm	870	1,000	1,000	1,000	1,000
Height of grab, closed	mm	2,416	2,416	2,521	2,649	2,814
Weight	kg	2,100	2,175	2,260	2,315	2,370



Wood Grab

Grab model GMH 50 heart-shaped (tip-to-tip closing, straight design, horizontal cylinders)

Size	m ²	2.20	2.50	2.80	3.20	3.60
Cutting width	mm	870	1,000	1,000	1,000	870
Height of grab, closed	mm	2,606	2,737	2,852	2,986	3,108
Weight	kg	2,190	2,250	2,340	2,380	2,470

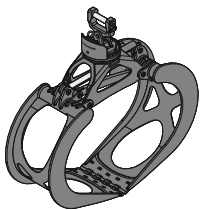

Wood Grab

Grab model GMH 50 combi-shaped (tip-to-tip closing, horizontal cylinders)

Size	m ²	3.20	3.20	3.60		
Cutting width	mm	870	1,000	1,000		
Height of grab, closed	mm	2,766	2,766	2,877		
Weight	kg	2,280	2,325	2,345		

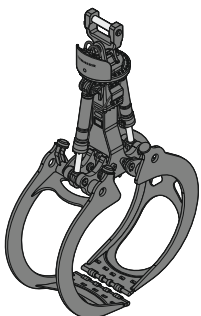

Wood Grab

Grab model GMH 80 round-shaped (complete overlapping, vertical cylinders)

Size	m ²	1.60	1.90	2.20	2.50	
Cutting width	mm	870	870	870	870	
Height of grab, closed	mm	2,908	2,984	3,062	3,140	
Weight	kg	2,260	2,305	2,340	2,380	

Equipment

Undercarriage

Stabilizer and dozer blade, rear	•
Stabilizer and dozer blade, rear and front	+
4-wheel steering	•
Trailer coupling	+
Mudguards (rear and front)	•
Shuttle axle lock, automatic	•
Protection for oscillating axle cylinders	+
Two lockable storage compartments	•

Uppercarriage

Uppercarriage right side light, 1 piece, LED	•
Railing on uppercarriage	+
Main battery switch for electrical system	•
Amber beacon, at uppercarriage, LED double flash	+
Protection for counterweight (both sides)	+
Protection for headlights	+
Protection for uppercarriage (both sides)	+
Protection for rear lights	+
Tool equipment, extended	•

Hydraulic System

Electronic pump regulation	•
Liebherr hydraulic oil from -20 °C to +40 °C	•
Liebherr hydraulic oil, biologically degradable	+
Magnetic rod in hydraulic tank	•
Bypass filter	+
Preheating hydraulic oil	+

Engine

Fuel anti-theft device	+
Air pre-filter with dust discharge	+
Automatic engine shut-down (time adjustable)	+
Preheating fuel	+
Preheating coolant	+
Preheating engine oil *	+

Cooling System

Radiator, large-mesh, for dust-intensive operation	•
Reversible fan drive, fully automatic	+
Protective grid in front of cooler intake	•



Operator's Cab

Stabilizer, control lever, left console	+
Stabilizer, proportional control on left joystick	•
Front headlights integral protective grid, left side, halogen	+
Front headlights integral protective grid, left side, LED	+
Cab lights rear, halogen	+
Cab lights rear, LED	+
Cab lights front, halogen	•
Cab lights front, LED	+
Armrest adjustable	•
Slewing gear brake Comfort, button on the left or right joystick	•
Driver profile, personalised (max. 5 drivers)	+
Operator's seat Comfort	•
Operator's seat Premium	+
Driving alarm (acoustic signal is emitted during travel, can be switched ON/OFF)	+
Fire extinguisher	+
Horn, button on left joystick	•
Joystick and wheel steering (slim version)	•
Cab elevation, rigid (LFC)	•
Automatic air conditioning	•
LIDAT, vehicle fleet management	•
Proportional control	•
Radio Comfort, control via display with handsfree set	+
Preparation for radio installation	•
Amber beacon, on cabin, LED double flash	+
Windows made from impact-resistant laminated safety glass	+
Windscreen wiper, roof	+
Windshield wiper, entire windscreen	•
Integral guard	•
Sun visor	+
Left control console, folding	•



Equipment

Boom lights, 2 pieces, halogen	•
Boom lights, 2 pieces, LED	+
Stick lights, 2 pieces, halogen	•
Stick lights, 2 pieces, LED	+
Boom shutoff (retract/extend), electronically	•
Equipment with electro-hydraulic end position control	•
Pressure warning mechanism hoist cylinder	•
Filter system for attachment	+
Electronic lift limitation	+
Boom cylinder cushioning	•
Stick camera (with separate monitor), bottom side, with protection	+
Load torque limitation	+
Pipe fracture safety valves hoist cylinders	•
Pipe fracture safety valves stick cylinders	•
Protection for piston rods, hoist cylinder	+
Protection for piston rods, stick cylinder	+
Retract stick without pressure	+
Overload warning device	+



Complete Machine

Lubrication	
Lubrication undercarriage, manually – decentralised (grease points)	•
Central lubrication system for uppercarriage and equipment, automatically	•
Central lubrication system for undercarriage, automatically	+
Central lubrication system, extension for attachment	+
Special coating	
Special coating, variants	+
Monitoring	
Rear view monitoring with camera	•
Side view monitoring with camera	•

• = Standard, + = Option

* = country-dependent

Options and/or special equipments, supplied by vendors other than Liebherr, are only to be installed with the knowledge and approval of Liebherr in order to retain warranty.

The Liebherr Group of Companies



Wide Product Range

The Liebherr Group is one of the largest construction equipment manufacturers in the world. Liebherr's high-value products and services enjoy a high reputation in many other fields. The wide range includes domestic appliances, aerospace and transportation systems, machine tools and maritime cranes.

Exceptional Customer Benefit

Every product line provides a complete range of models in many different versions. With both their technical excellence and acknowledged quality, Liebherr products offer a maximum of customer benefits in practical applications.

State-of-the-art Technology

To provide consistent, top quality products, Liebherr attaches great importance to each product area, its components and core technologies. Important modules and components are developed and manufactured in-house, for instance the entire drive and control technology for construction equipment.

Worldwide and Independent

Hans Liebherr founded the Liebherr family company in 1949. Since then, the family business has steadily grown to a group of more than 130 companies with nearly 44,000 employees located on all continents. The corporate headquarters of the Group is Liebherr-International AG in Bulle, Switzerland. The Liebherr family is the sole owner of the company.

www.liebherr.com