

ENGINE

Agco Power 44 AWF 4-cylinder, turbocharged and intercooled diesel engine, Stage IV

Displacement	4,4 l
Output	106 (145) kW (hp)/1900 rpm
Torque (max.)	580 Nm / 1500 rpm
Torque (/ 1000 rpm)	575 Nm
Capacity of the fuel tank	150 l
Capacity of the AdBlue tank	40 l

ELECTRIC APPLIANCES

Alternator with a multi-groove flat belt and automatic tightening	24V/100 Ah
Starter	4,5 kW
Batteries (under the cabin, easy to maintain)	2 x 170 Ah
Electric engine heater	1100 W

AXLES

ZF axles, automatic friction locks in the front and rear axles. A 100 % gear lock, which can be switched on even while the drive is on, is available as an option.

Frame oscillation \pm 400 mm. Automatic Oscillation Control System AOC.

TRANSMISSION AND GEARBOX

Hydrostatic transmission, 4-wheel drive. Range gearbox, 2-stage Power Shift electric control. Drive controls both in the front and rear as standard.

DRIVE SPEED FORWARD/REVERSE

1. gear	0...10 km/h
2. gear	0...46 km/h

WHEELS

Front and rear tyres 580/65B34	Nokia TRI/TL
Rim DW20-34, reinforced by flanging, valve guards	

BRAKES

Oil pressure operated brakes in oil bath on the front and rear

Parking brake	Range gearbox operates as parking brake, electric control.
---------------	--

STEERING

Hydrostatic LS Orbitrol steering

Steering angle of the articulated joint	\pm 42°
Turning radius from the centre of the tyre	5,25 m

Steering is also possible via the left control lever

HYDRAULICS

Danfoss valves, versatile and precise control systems

Variable displacement axial piston pump, max. flow	252 l/min
Electric output power control available as an option	
Max operating pressure (normal/turbo hydraulics)	225 bar / 245 bar
Filling capacity of the hydraulic system	220 l

CABIN

ROPS and FOPS tested

Noise level LpA / LWA	67,5 dBA / 101,5 dBA
-----------------------	----------------------

The working environment of the operator is spacious and low-noise with excellent all-round visibility. The ergonomic, operator-friendly cabin is comfortable, and it enables the operator to control the machine easily and safely. It's high capacity heater and climate control ensures a pleasant working temperature throughout the whole year.

Steering column, with two articulated joints and height adjustment, provides a pleasant driving position, and can, as required, be turned out of the way to the front. The seat swivels freely, and its sturdy armrests are easy to adjust for operators of different sizes and varying operating habits.

The control panel, which is located beside the armrest, includes the switches for the most important functions of the machine. The cabin can be hydraulically tipped in two stages with a manually operated pump for easy service access.

FRONT LOADER

Mechanical self-leveling, position indicator for the bucket.

Operating pressure (normal/turbo hydraulics)	225 bar / 245 bar
Lifting force at the lowest position (normal/turbo hydraulics)	7000 kp / 7500 kp
Lifting force at the highest position (normal/turbo hydraulics)	5300 kp / 5600 kp
Loading height (bottom of the level bucket)	3790 mm
Recommended bucket volume (depending on the density of the material being loaded)	SAE 1900 l

MAIN DIMENSIONS

Length/width	9380 mm / 2600 mm
Cabin height/backhoe height	3200 mm / 4340 mm
Ground clearance	510 mm
Weight (without buckets and depending on the configuration) ca.	12 300 kg

BACKHOE UNIT

Knuckle boom, straight backhoe available as an option

Operating pressure (normal/turbo hydraulics)	225 bar / 245 bar
Digging reach	6410 mm
Digging depth	4450 mm
Loading height (bottom of the level bucket)	3910 mm
Swing angle of the backhoe	180 + 54°
Lifting force at max. reach (normal/turbo hydraulics)	1600 kp / 1750 kp
Slewing torque	4320 kpm
Recommended bucket volume	SAE 410 l

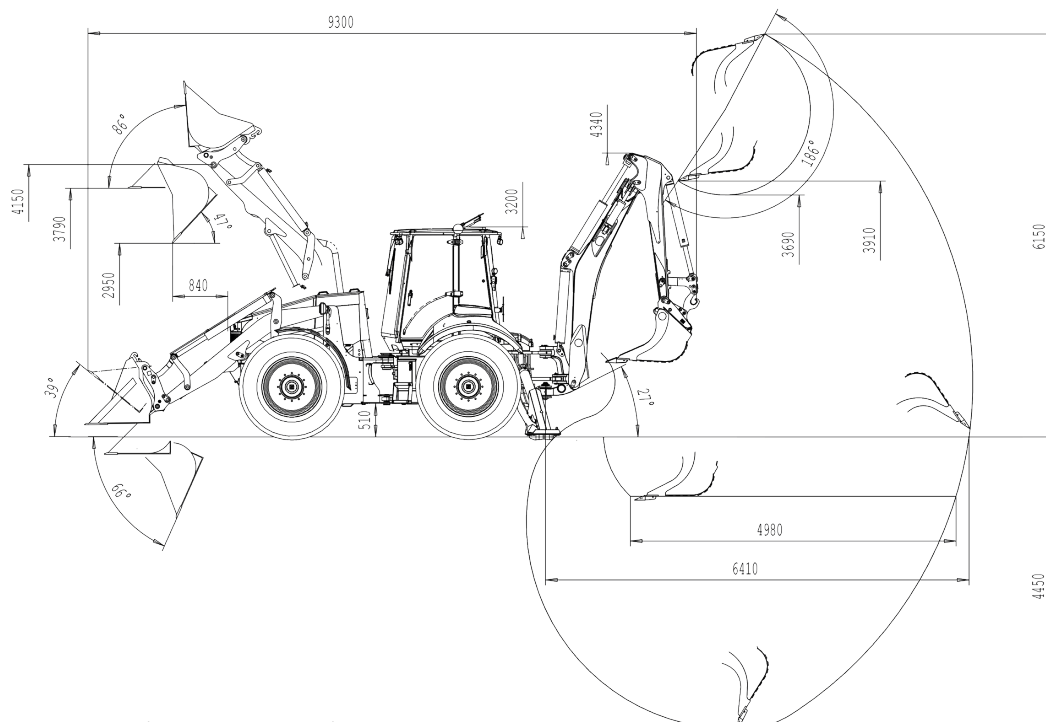

We reserve the right to make alterations.