

# Technical Description Wheel Loader

# L 564 2plus2

**Tipping Load** 15285 kg  
**Bucket Capacity** 4,0 - 8,5 m<sup>3</sup>  
**Operating Weight** 22,4 t  
**Engine Output** 183 kW (249 HP)



# LIEBHERR

# Technical Data



## Engine

|                                    |  |             |
|------------------------------------|--|-------------|
| Libherr diesel engine              | D 926 TI-E A2  |             |
|                                    | 6-cylinder, inline engine, water-cooled exhaust-turbo charged with intercooler       |             |
| Power output according to ISO 9249 | 183 kW (249 HP)  | at 2000 RPM |
| Max. torque                        | 1074 Nm  | at 1200 RPM |
| Displacement                       | 9,96 litres  |             |
| Bore/Stroke                        | 122/142 mm   |             |
| Air cleaner                        | Dry type with main and safety element, pre-cleaner, service indicator on LCD display |             |
| Electrical system                  |  |             |
| Operating voltage                  | 24 V   |             |
| Battery                            | 2 x 143 Ah/12 V  |             |
| Alternator                         | Three-phase AC, 28 V/55 A  |             |
| Starter motor                      | 24 V/5,4 kW  |             |



## Travel Gear

|                                   |   |             |
|-----------------------------------|---|-------------|
| Stepless hydrostatic travel drive |   |             |
| Type "2plus2"                     | Variable-pitch swashplate pump and two axial piston motors in closed circuit with one axle transfer case  |             |
| Filtering system                  | Suction-side filter for the closed circuit  |             |
| Control                           | By travel and inching pedal. The inching pedal makes it possible to control the tractive and thrust forces steplessly at full engine speed. The Liebherr joystick is used to control forward and reverse travel |             |
| Travel speeds                     | Stage 1   | 0–10,0 km/h |
|                                   | Stage 2 and A2  | 0–20,0 km/h |
|                                   | Stage A3  | 0–40,0 km/h |
|                                   | Forwards and in reverse with tyre size 26.5R25  |             |



## Axles

|                 |  |  |
|-----------------|--|--|
| All-wheel drive |  |  |
| Front axle      | Fixed  |  |
| Rear axle       | Centre pivot, with 13° oscillating angle to each side. Obstacles up to 560 mm in height can be driven over (with all four wheels remaining in contact with the ground) |  |
| Differentials   | Automatic limited-slip differentials with 45 % locking action in both axles  |  |
| Final drive     | Planetary final drive in the wheel hubs  |  |
| Track width     | 2230 mm with all types of tyres  |  |



## Brakes

|                              |   |  |
|------------------------------|---|--|
| Wear-free service brake      | Self-locking of the hydrostatic travel drive (acting on all four wheels) and additional pump-accumulator brake system with wet multi-disc brakes located in the wheel hubs. Two separate brake circuits |  |
| Parking brake                | Electro-hydraulically actuated spring-loaded brake system on the transmission.  |  |
| Braking system complies with | German road-vehicle construction and use regulations.   |  |



## Tyres

|                 |                                      |  |
|-----------------|--------------------------------------|--|
| Available sizes | 23.5R25                              |  |
|                 | 26.5R25                              | Tubeless radial or cross-ply tyres on well-base rims |
| Special tyres   | By arrangement with the manufacturer |  |



## Steering

|                       |  |  |
|-----------------------|--|--|
| Design                | "Load-sensing" variable axial piston pump. Central pivot with two double-acting, damped steering cylinders |  |
| Angle of articulation | 40° (to each side)   |  |
| Emergency steering    | Electro-hydraulic emergency steering system  |  |



## Attachment Hydraulics

|                         |   |  |
|-------------------------|---|--|
| Design                  | "Load-sensing" variable axial piston pump with output control and pressure cutoff   |  |
| Max. flow               | 290 l/min.  |  |
| Max. operating pressure | 325 bar   |  |
| Cooling                 | Hydraulic oil cooling using thermostatically controlled fan and oil cooler  |  |
| Filtering               | Return-line filter in the hydraulic reservoir   |  |
| Control                 | "Liebherr-Joystick" with hydraulic servo control  |  |
| Lift circuit            | Lifting, neutral, lowering and float positions controlled by Liebherr joystick with detent; automatic lifting-limit circuit |  |
| Tilt circuit            | Tilt back, neutral, dump automatic bucket positioning   |  |



## Attachments

|                            |   |          |
|----------------------------|---|----------|
| Geometry                   | Powerful Z-pattern linkage with tilt cylinder and cast steel cross-tube |          |
| Bearings                   | Sealed  |          |
| Cycle time at nominal load | Lifting   | 5,6 sec. |
|                            | Dumping   | 2,0 sec. |
|                            | Lowering (empty)  | 3,5 sec. |



## Operator's Cab

|                             |   |  |
|-----------------------------|---|--|
| Design                      | ROPS/FOPS cab resiliently mounted on rear section of vehicle and noise-damped; lockable door with sliding window and 180° opening angle; emergency exit; toughened safety glass windows, tinted; adjustable steering column and joystick bracket as standard equipment; ROPS roll-over protection according to DIN/ISO 3471/EN 474-3 and FOPS falling objects protection according to DIN/ISO 3449/EN 474-1 |  |
| Operator's seat             | 6 way adjustable seat with seat belt, adjustable for operator's weight  |  |
| Cab heating and ventilation | With defrosting, fresh-air filter, air-recirculated-air mode and heater supplied from engine's cooling system. Air conditioning is standard equipment   |  |



## Noise Emission

|            |                       |           |
|------------|-----------------------|-----------|
|            | In the operator's cab |           |
|            | Without blower        | 69 dB(A)  |
| ISO 6396   | Max. blower output    | 71 dB(A)  |
| 2000/14/EC | Outside cab           | 105 dB(A) |



## Capacities

|                                      |        |
|--------------------------------------|--------|
| Fuel tank                            | 330 l  |
| Engine oil (including filter change) | 18 l   |
| Pump distributor gears               | 2,5 l  |
| Transmission "2plus2"                | 11,5 l |
| Front axle/wheel hubs                | 51 l   |
| Rear axle/wheel hubs                 | 51 l   |
| Hydraulic tank                       | 120 l  |
| Hydraulic system, total              | 240 l  |
| Air condition system (R134a)         | 1800 g |

# Dimensions

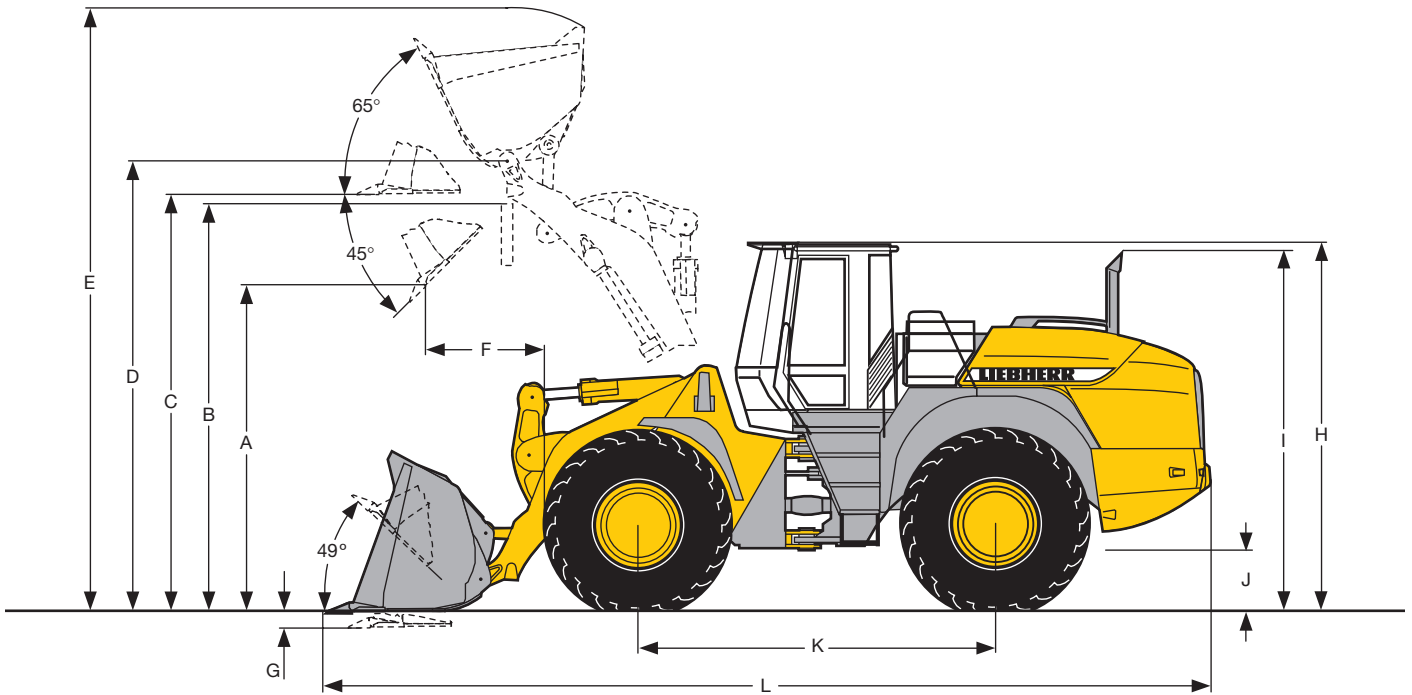

| Bucket Type  | Loading Bucket   |       |       |       |       |       | Rock Bucket |       |
|--|------------------|-------|-------|-------|-------|-------|-------------|-------|
|  | T                | T     | E     | T     | E     | T     | T           |       |
| Cutting tools  |                  |       |       |       |       |       |             |       |
| Bucket capacity  | m <sup>3</sup>   | 4,0   | 4,0   | 4,0   | 4,5   | 4,5   | 5,0         | 3,5   |
| Bucket width   | mm               | 3000  | 3000  | 3000  | 3000  | 3000  | 3000        | 3000  |
| Specific material weight                               | t/m <sup>3</sup> | 1,8   | 1,8   | 1,8   | 1,6   | 1,6   | 1,4         | 2,0   |
| A Dumping height at max. lift height and 45° discharge | mm               | 3150  | 3220  | 3210  | 3160  | 3155  | 3080        | 3330  |
| B Dump-over height                                     | mm               | 3900  | 3900  | 3900  | 3900  | 3900  | 3900        | 3900  |
| C Max. height of bucket bottom                         | mm               | 4025  | 4025  | 4025  | 4025  | 4025  | 4025        | 4025  |
| D Max. height of bucket pivot point                    | mm               | 4355  | 4355  | 4355  | 4355  | 4355  | 4355        | 4355  |
| E Max. operating height                                | mm               | 6010  | 5855  | 5855  | 5945  | 5945  | 6025        | 5745  |
| F Reach at max. lift height and 45° discharge          | mm               | 1250  | 1180  | 1190  | 1240  | 1245  | 1325        | 1095  |
| G Digging depth  | mm               | 100   | 100   | 100   | 100   | 100   | 100         | 100   |
| H Height above cab                                     | mm               | 3540  | 3540  | 3540  | 3540  | 3540  | 3540        | 3540  |
| I Height above exhaust                                 | mm               | 3450  | 3450  | 3450  | 3450  | 3450  | 3450        | 3450  |
| J Ground clearance                                     | mm               | 550   | 550   | 550   | 550   | 550   | 550         | 550   |
| K Wheelbase  | mm               | 3450  | 3450  | 3450  | 3450  | 3450  | 3450        | 3450  |
| L Overall length                                       | mm               | 8730  | 8630  | 8450  | 8710  | 8530  | 8830        | 8510  |
| Turning circle radius over outside bucket edge         | mm               | 6990  | 6930  | 6890  | 6955  | 6915  | 6990        | 6895  |
| Lifting force (SAE)                                    | kN               | 245   | 245   | 245   | 245   | 245   | 245         | 245   |
| Breakout force (SAE)                                   | kN               | 170   | 185   | 185   | 172   | 172   | 156         | 206   |
| Tipping load, straight*                                | kg               | 16800 | 17410 | 17190 | 17290 | 17090 | 17190       | 17490 |
| Tipping load, articulated at 37°*                      | kg               | 15020 | 15500 | 15290 | 15400 | 15180 | 15280       | 15580 |
| Tipping load, articulated at 40°*                      | kg               | 14750 | 15285 | 15095 | 15180 | 15005 | 15095       | 15335 |
| Operating weight*                                      | kg               | 22480 | 22450 | 22700 | 22600 | 22800 | 22700       | 22400 |

\* The figures shown here are valid with Michelin XHA 26.5R25 tyres and include all lubricants, a full fuel tank, the ROPS/FOPS cab and the operator.

Different tyres and optional equipment will change the operating weight and overturning loads.



= Rehandling bucket



= Loading bucket with back grading edge

T = Welded-on tooth holder with add-on teeth

E = Four-piece, bolt-on reversible cutting edge

The attachments are secured directly to the lifting arms.

# Attachments

## Light Material Bucket

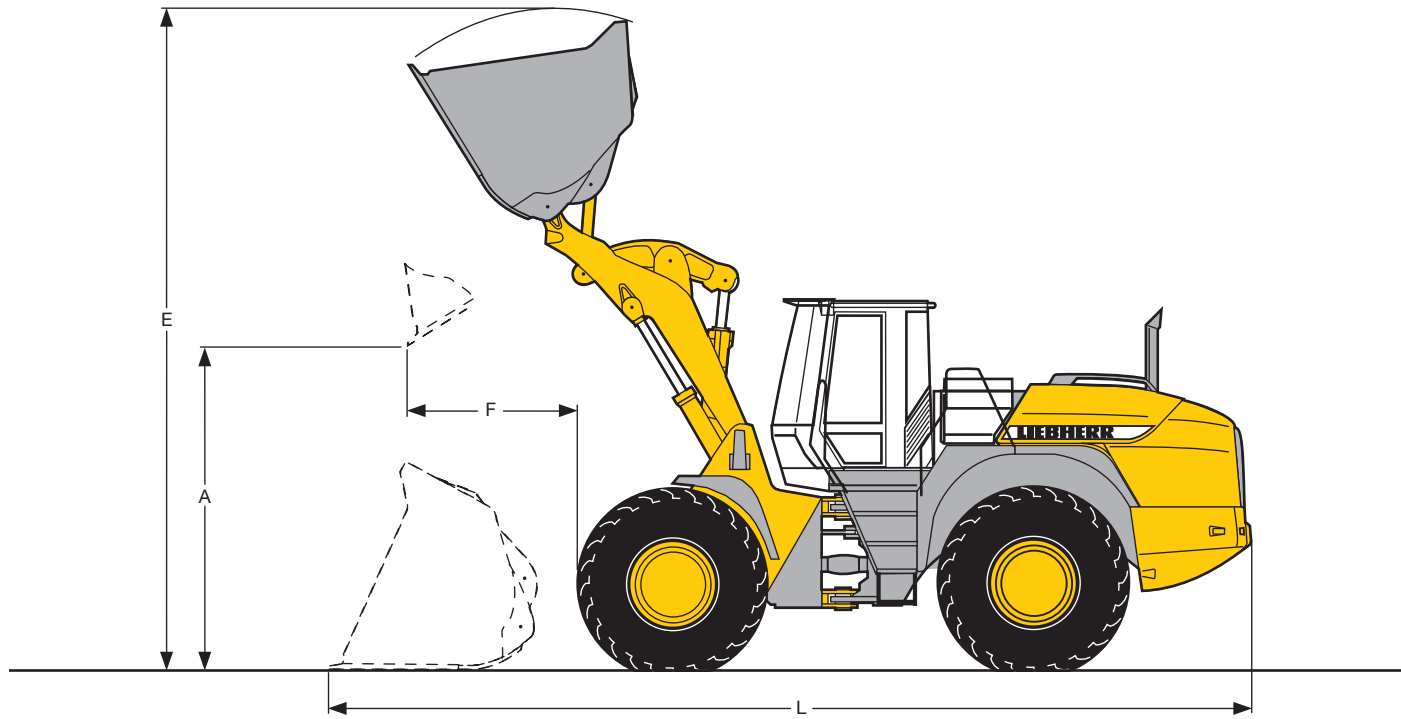

### Light Material Bucket with Bolt-On Cutting Edge

|   |                                    |                  |       |       |
|---|------------------------------------|------------------|-------|-------|
|   | Bucket capacity                    | m <sup>3</sup>   | 6,5   | 8,5   |
|   | Bucket width                       | mm               | 3200  | 3500  |
|   | Specific material weight           | t/m <sup>3</sup> | 1,0   | 0,8   |
| A | Dumping height at max. lift height | mm               | 2950  | 2810  |
| E | Max. operating height              | mm               | 6210  | 6410  |
| F | Reach at maximum lift height       | mm               | 1380  | 1530  |
| L | Overall length                     | mm               | 8840  | 9070  |
|   | Tipping load, straight*            | kg               | 15770 | 15360 |
|   | Tipping load, articulated at 40°*  | kg               | 13840 | 13480 |
|   | Operating weight*                  | kg               | 23000 | 23300 |

\* The figures shown here are valid with Michelin XHA 26.5R25 tyres and include all lubricants, a full fuel tank, the ROPS/FOPS cab and the operator.

Different tyres and optional equipment will change the operating weight and overturning loads.

The attachments are secured directly to the lifting arms.

# Attachments

## High-Dump Bucket

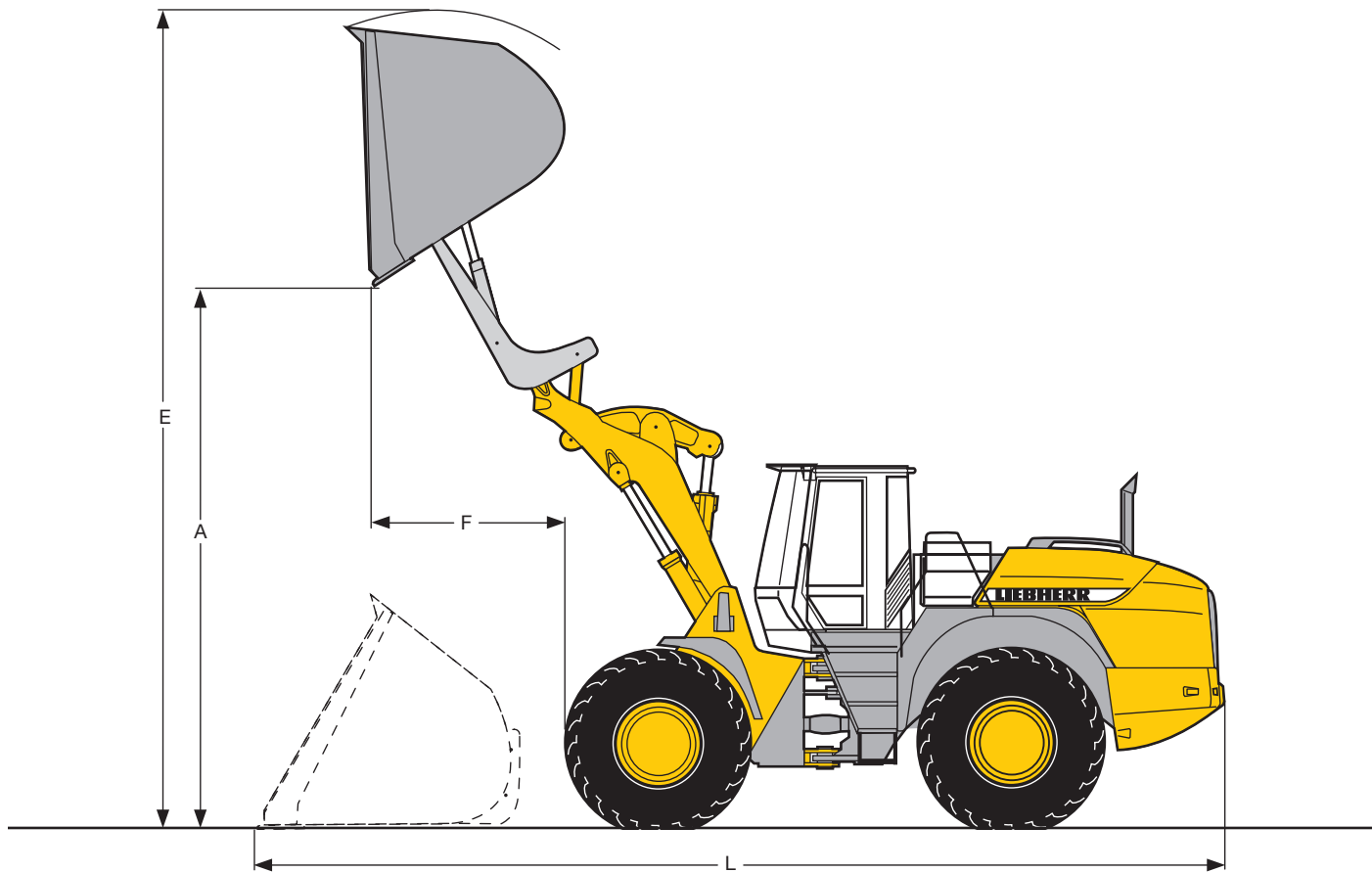

### High-Dump Bucket with Bolt-On Cutting Edge

|   |                                    |                  |       |
|---|------------------------------------|------------------|-------|
|   | Bucket capacity                    | m <sup>3</sup>   | 6,5   |
|   | Bucket width                       | mm               | 3200  |
|   | Specific material weight           | t/m <sup>3</sup> | 0,8   |
| A | Dumping height at max. lift height | mm               | 5300  |
| E | Max. operating height              | mm               | 7600  |
| F | Reach at maximum lift height       | mm               | 1840  |
| L | Overall length                     | mm               | 9370  |
|   | Tipping load, straight*            | kg               | 12100 |
|   | Tipping load, articulated at 40°*  | kg               | 10600 |
|   | Operating weight*                  | kg               | 24500 |

\* The figures shown here are valid with Michelin XHA 26.5R25 tyres and include all lubricants, a full fuel tank, the ROPS/FOPS cab and the operator.

Different tyres and optional equipment will change the operating weight and overturning load.

The attachments are secured directly to the lifting arms.

# Tipping Load

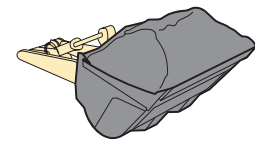
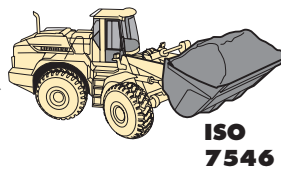
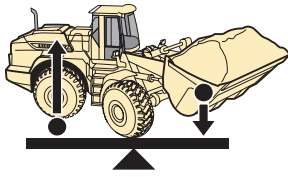

## What is tipping load?

Load at centre of gravity of working equipment, so that the wheel loader just begins to tip over the front axle. This the most unfavourable static-load position for the wheel loader. Liftings arms horizontal, wheel loader fully articulated at centre pivot.

## Pay load.

The pay load must not exceed 50 % of the tipping load when articulated. This is equivalent to a static stability-margin factor of 2,0.

## Bucket capacity.

The bucket volume is determined from the pay load.

$$\text{Pay load} = \frac{\text{Tipping load, articulated}}{2}$$

$$\text{Bucket capacity} = \frac{\text{Pay load (kg)}}{\text{Specific bulk weight of material (t/m}^3\text{)}}$$

## Selection of Buckets



### Rock Bucket

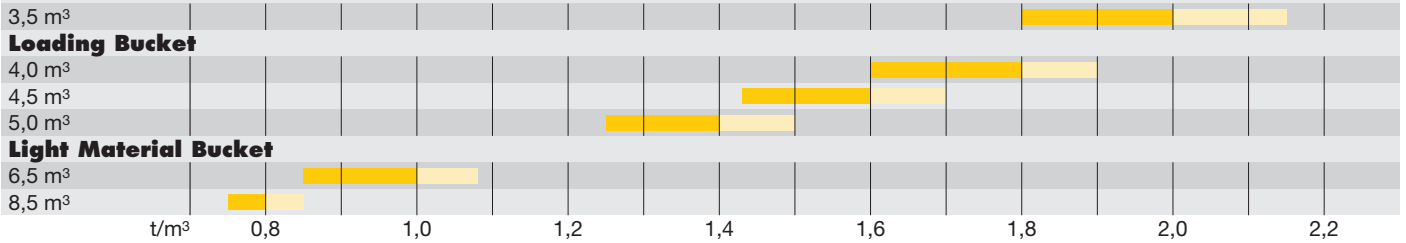

## Bulk Material Densities and Bucket Filling Factors

|                  | t/m <sup>3</sup> | %   |                       | t/m <sup>3</sup> | %   |                | t/m <sup>3</sup> | %   |
|------------------|------------------|-----|-----------------------|------------------|-----|----------------|------------------|-----|
| Gravel, moist    | 1,9              | 105 | Clay, natural         | 1,6              | 110 | Granite        | 1,8              | 95  |
| dry              | 1,6              | 105 | dry                   | 1,4              | 110 | Limestone,     |                  |     |
| wet, 6–50 mm     | 2,0              | 105 | wet                   | 1,65             | 105 | hard           | 1,65             | 95  |
| dry, 6–50 mm     | 1,7              | 105 | Clay and gravel,      |                  |     | soft           | 1,55             | 100 |
| crushed stone    | 1,5              | 100 | dry                   | 1,4              | 110 | Sandstone      | 1,6              | 100 |
| Sand, dry        | 1,5              | 110 | wet                   | 1,6              | 100 | Slate          | 1,75             | 100 |
| moist            | 1,8              | 115 | Earth, dry            | 1,3              | 115 | Bauxite        | 1,4              | 100 |
| wet              | 1,9              | 110 | wet excavated         | 1,6              | 110 | Gypsum, broken | 1,8              | 100 |
| Gravel and sand, |                  |     | Topsoil               | 1,1              | 110 | Coke           | 0,5              | 110 |
| dry              | 1,7              | 105 | Weathered rock        |                  |     | Slag, broken   | 1,8              | 100 |
| wet              | 2,0              | 100 | 50 % rock, 50 % earth | 1,7              | 100 | Coal           | 1,1              | 110 |
| Sand and clay    | 1,6              | 110 | Basalt                | 1,95             | 100 |                |                  |     |

## Tyre Sizes

|                         |    | Width over tyres |      | Change in vertical dimensions |    | Use                 |
|-------------------------|----|------------------|------|-------------------------------|----|---------------------|
|                         |    | mm               | mm   | mm                            | mm |                     |
| 23.5R25 Dunlop PG 120   | L5 | 2837             | + 5  |                               |    | Stone               |
| 26.5R25 Dunlop T7 LD    | L3 | 2910             | + 35 |                               |    | Gravel              |
| 26.5R25 Michelin XHA    | L3 | 2930             | 0    |                               |    | Gravel              |
| 23.5R25 Michelin X-MINE | L5 | 2870             | + 10 |                               |    | Scap material/Waste |
| 23.5R25 Michelin XLD D2 | L5 | 2850             | - 15 |                               |    | Stone/Mining spoil  |
| 705/70R25 Michelin XLD  | L3 | 2950             | - 70 |                               |    | Gravel              |
| 23.5R25 Good Year GP2B  | L2 | 2850             | - 20 |                               |    | Sand                |
| 26.5R25 Good Year RL2+  | L2 | 2930             | + 35 |                               |    | Gravel              |

Before operating the vehicle with tire foam filling or tire protection chains, please discuss this with Liebherr-Werk Bischofshofen.

# Equipment



## Basic Machine

|   | S | O |
|---|---|---|
| Liebherr-2plus2-travelgear                          | • |   |
| Ride control  | • |   |
| Liebherr shock absorbing element                    |   | x |
| Automatic travel mode                               | • |   |
| Kick-Down   | • |   |
| 20 km/h speed limiting                              |   | • |
| Electronical theft protection                       |   | • |
| Creep speed/Cruise control                          | • |   |
| Electronic crowding force control                   | • |   |
| Combined inching-braking system                     | • |   |
| Multi-disc limited slip differentials in both axles | • |   |
| Air cleaner system with pre-filter                  | • |   |
| Particle protection for radiator                    | • |   |
| Reversible fan drive                                |   | • |
| Emergency steering system                           | • |   |
| Bio degradedable hydraulic oil                      |   | • |
| Headlights  | • |   |
| Tail lights   | • |   |
| Working area lights at front                        | • |   |
| Working area lights at rear                         | • |   |
| Battery master switch                               | • |   |
| Pre-heat system for cold starting                   | • |   |
| Towing hitch  | • |   |
| Lockable doors, service flap an engine hood         | • |   |
| Toolbox with toolkit                                | • |   |
| Dust filter system                                  |   | • |
| Protective ventilation system                       | • |   |
| Amber beacon  | • |   |
| Acoustical warning device for travel in reverse     | • |   |
| Exhaust pipe – special steel                        | • |   |
| Noise suppression package “101”                     |   | • |
| Automatic central lubrication system                |   | • |
| Road ballast  |   | x |



## Operator's Cab

|   | S | O |
|---|---|---|
| Driver's cab with reduced overall height – 90 mm            |   | • |
| Noise-damped ROPS/FOPS cab with tinted safety glass         | • |   |
| Joystick steering   | • |   |
| 2in1 steering system – changeable                           |   | • |
| Hot-water heater with defroster and recirculated-air system | • |   |
| Adjustable steering column                                  | • |   |
| Liebherr joystick control – adjustable                      | • |   |
| Air conditioning system                                     | • |   |
| Liebherr operator's seat – adjustable in 6 ways             | • |   |
| Air sprung operator's seat with seat belt                   |   | • |
| Sliding window  | • |   |
| Emergency exit  | • |   |
| Floor mat   | • |   |
| Wash/wipe system for windscreen and rear window             | • |   |
| Interior rear-view mirror                                   | • |   |
| Sun visor   | • |   |
| Bottle holder   | • |   |
| Clothes hook  | • |   |
| Storage box with cooling funktion                           | • |   |
| Storage compartment   | • |   |
| Plug  | • |   |
| Ashtray   | • |   |
| Horn  | • |   |
| Provision for radio including loudspeaker                   |   | • |
| Radio set   |   | • |
| Tool kit  | • |   |
| Operator's package  | • |   |



## Instruments for:

|                                       | S | O |
|---------------------------------------|---|---|
| Diesel engine pre-heat                | • |   |
| Engine oil temperature                | • |   |
| Fuel reserve                          | • |   |
| Timer for hours of operation          | • |   |
| Travel speed ranges and gear selected | • |   |
| Forward – reverse travel              | • |   |
| Forward travel                        | • |   |

|                          | S | O |
|--------------------------|---|---|
| Reverse travel           |   | • |
| Speedometer              |   | • |
| Rev. counter             |   | • |
| Clock                    |   | • |
| Safety belt              |   | x |
| Flashing turn indicators |   | • |
| High-beam headlights     |   | • |
| Diagnosis system         |   | • |



## Warning Lights for:

|  | S | O |
|--|---|---|
| Engine oil pressure                    | • |   |
| Engine overheat                        | • |   |
| Parking brake                          | • |   |
| Hydraulic oil temperature              | • |   |
| Air cleaner blockage                   | • |   |
| Battery charge                         | • |   |
| Flow through emergency steering system | • |   |
| Road travel                            |   | x |



## Audible Warnings for:

|                             | S | O |
|-----------------------------|---|---|
| Engine oil pressure         | • |   |
| Engine overheat             | • |   |
| Overheat of hydraulic fluid | • |   |
| Emergency steering system   |   | x |



## Function Keys for:

|                                      | S | O |
|--------------------------------------|---|---|
| Speed range selection                | • |   |
| Air conditioning                     | • |   |
| Hazard warning flashers              | • |   |
| Parking brake                        | • |   |
| Electronic tractive force adaptation | • |   |
| Creep speed                          | • |   |
| Ride control                         | • |   |
| Automatic bucket positioner          | • |   |
| Hoist kick-out                       | • |   |
| Additional hydraulics                | • |   |
| Float position                       | • |   |
| Headlights                           | • |   |
| Working lights front                 | • |   |
| Working lights rear                  | • |   |
| Road travel                          | • |   |
| Wash/wipe system for rear window     | • |   |
| Amber beacon                         | • |   |
| Mode switch                          | • |   |
| Blower                               | • |   |
| Heater                               | • |   |
| Adjusting the crowding force counter | • |   |



## Equipment

|   | S | O |
|---|---|---|
| Z-bar linkage   | • |   |
| Z-bar linkage “High Lift”                                       |   | x |
| Industrial Z-bar linkage  |   | • |
| Parallel linkage  |   | x |
| Hydraulic servo control of working hydraulics                   | • |   |
| Automatic bucket positioner – adjustable                        | • |   |
| Automatic hoist kick out – adjustable                           | • |   |
| Float position  | • |   |
| Loading buckets with and without teeth, or bolt-on cutting edge |   | • |
| High-dump bucket  |   | • |
| Light material bucket   |   | • |
| Fork carrier and lift forks                                     |   | • |
| Hydraulic quick-change device                                   |   | • |
| 3rd hydraulic control circuit                                   |   | • |
| 3rd and 4th hydraulic control circuits                          |   | • |
| Comfort control   |   | • |
| Country-specific versions                                       |   | • |

S = Standard, O = Option, X = not available

# The Liebherr Wheel Loaders

## Stereoloader



|                  |                | <b>L 506</b> | <b>L 507</b> | <b>L 508</b> | <b>L 509</b> | <b>L 512</b> | <b>L 514</b> |
|------------------|----------------|--------------|--------------|--------------|--------------|--------------|--------------|
| Tipping load     | kg             | 3215         | 3465         | 3895         | 4440         | 4615         | 5305         |
| Bucket capacity  | m <sup>3</sup> | 0,8          | 0,9          | 1,0          | 1,1          | 1,3          | 1,5          |
| Operating weight | kg             | 4810         | 4930         | 5310         | 5740         | 7000         | 7700         |
| Engine output    | kW/HP          | 44/60        | 46/63        | 49/67        | 52/71        | 59/80        | 72/98        |

## Wheel Loader



|                  |                | <b>L 524</b> | <b>L 534</b> | <b>L 538</b> | <b>L 544 2plus2</b> |
|------------------|----------------|--------------|--------------|--------------|---------------------|
| Tipping load     | kg             | 7005         | 8625         | 9000         | 10600               |
| Bucket capacity  | m <sup>3</sup> | 2,0          | 2,4          | 2,5          | 3,0                 |
| Operating weight | kg             | 10100        | 12100        | 12380        | 15300               |
| Engine output    | kW/HP          | 81/110       | 100/136      | 100/136      | 121/165             |



|                  |                | <b>L 554 2plus2</b> | <b>L 564 2plus2</b> | <b>L 574 2plus2</b> | <b>L 580 2plus2</b> |
|------------------|----------------|---------------------|---------------------|---------------------|---------------------|
| Tipping load     | kg             | 12270               | 15285               | 16690               | 17850               |
| Bucket capacity  | m <sup>3</sup> | 3,5                 | 4,0                 | 4,5                 | 5,0                 |
| Operating weight | kg             | 17300               | 22450               | 24220               | 24740               |
| Engine output    | kW/HP          | 145/198             | 183/249             | 195/265             | 195/265             |

01.03

## Environmental protection can help you earn money!

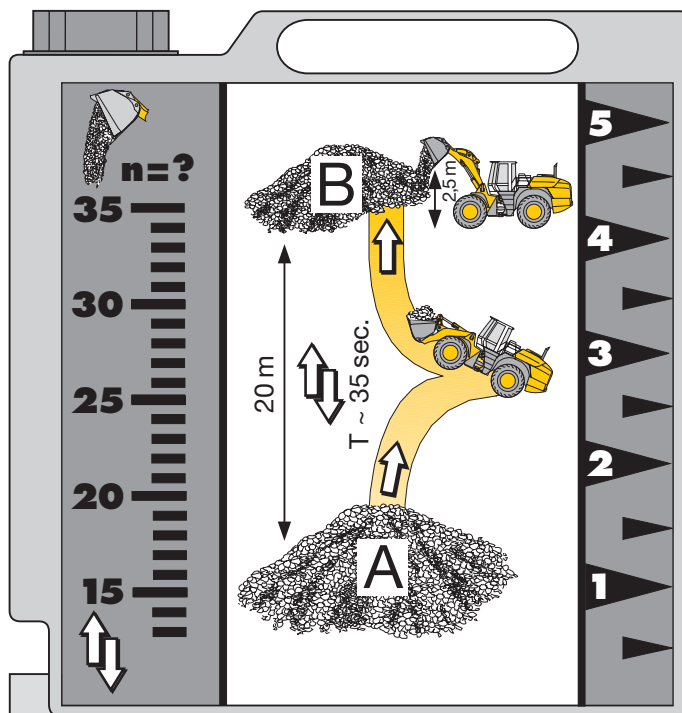

### The Liebherr Standard Consumption Test - easy to reproduce and practical.

Every Liebherr dealer will provide you with this measuring-tank kit free of charge or, on request, will carry out the standard fuel consumption test on your premises. It's so easy: you simply determine the number of loading cycles that can be carried out with 5 litres of diesel. The material is taken from pile A and carried over a distance of 20 metres to point B. The time needed for each working cycle should be 35 seconds. Discharge at point B should take place from a height of 2,5 m. The working cycles continue until the 5 litres of diesel in the external measuring tank have been used up. The loader's fuel consumption per operating hour is calculated as follows:

$$\frac{400}{\text{Number of loading cycles}} = \text{consumption per hour}$$

### Values for the Liebherr Wheel Loaders

|                           | Numbers of working cycles | Litres/100 tons | Litres/hour |
|---------------------------|---------------------------|-----------------|-------------|
| L 524: 2,0 m <sup>3</sup> | n = 48                    | 2,9             | 8,3         |
| L 534: 2,4 m <sup>3</sup> | n = 40                    | 2,8             | 10,0        |
| L 538: 2,5 m <sup>3</sup> | n = 40                    | 2,8             | 10,0        |
| L 544: 3,0 m <sup>3</sup> | n = 35                    | 2,6             | 11,4        |
| L 554: 3,5 m <sup>3</sup> | n = 33                    | 2,4             | 12,1        |
| L 564: 4,0 m <sup>3</sup> | n = 24                    | 2,9             | 16,7        |
| L 574: 4,5 m <sup>3</sup> | n = 23                    | 2,7             | 17,4        |
| L 580: 5,0 m <sup>3</sup> | n = 22                    | 2,7             | 18,2        |

Liebherr-Werk Bischofshofen GmbH

Postfach 49, A-5500 Bischofshofen

+43 (0)6462 888-0, Fax +43 (0)6462 888-385

www.liebherr.com, E-Mail: info@lbh.liebherr.com