

GET IN AND GO

The wheel loaders and telescopic wheel loaders
KL10.5/KL12.5/KL18.5/KL19.5/KL25.5/KL25.5T



KRAMER
on the safe side



A broad range of application areas

Discover the all-wheel wheel loaders and telescopic wheel loaders in the 1 - 4.5 tonne class

The compact equipment is the main segment of Kramer-Werke GmbH. The efficient machines have been planned down to the finest detail and impress with the tried-and-tested design principle, which provides unbeatable manoeuvrability. Due to their narrow and low design, the machines are also in demand where large machines can't fit: tight access roads, work in stables, warehouses or other confined conditions are ideal for using these machines.



On the safe side with Kramer

Rich in tradition, the Kramer brand has been established on the market for many years and in particular stands for one value: **Safety**. The high quality of the innovative machines is only one aspect of this. As a company, Kramer is also a reliable choice for customers and dealers because the experience and innovative power of the company ensures for investment and future security. In short – you are always on the safe side with Kramer: **“Kramer – on the safe side!”**

➔ **ON THE SAFE SIDE**

Table of contents

Vehicle structure

One-piece vehicle frame
Advantages at a glance
Types of steering

04

Wheel loaders and telescopic wheel loaders at a glance

Wheel loader: KL10.5, KL12.5,
KL18.5, KL19.5, KL25.5
Telescopic wheel loader: KL25.5T

08

Compact design

Dimensions
Power to weight ratio

10

Machine components and accessories

Attachments, quick coupler system
Hydraulics
Loader units

12

Machine Highlights

Engines
Drive system
Hydraulics

16

Cabin concept

Setup
Equipment
Operating elements

20

Drive train and tyres

Engines
Drive
Tyres

22

Technical Data and Dimensions

28

Operating and performance data wheel

LOADERS AND TELESCOPIC WHEEL LOADERS	KL10.5	KL12.5	KL18.5	KL19.5
Engine output (optional) [kW]	23	23 (27)	34.3	34.3 (41.1)
Bucket capacity [m³]	0.25	0.35	0.45	0.55
Bucket tipping load [kg]	1,080	1,250	1,800	1,980
Payload on pallet forks S=1.25 [kg]	650	750	1,200	1,600
Operating weight [kg]	1,555	1,620	2,645	3,450

	KL19.5L	KL25.5	KL25.5L	KL25.5T
Engine output (optional) [kW]	34.3 (41.1)	34.3 (41.1)	34.3 (41.1)	34.3 (41.1)
Bucket capacity [m³]	0.55	0.65	0.65	0.65
Bucket tipping load [kg]	1,780	2,340	2,140	2,500
Payload on pallet forks S=1.25 [kg]	1,450	1,750	1,600	1,650
Operating weight [kg]	3,550	3,800	3,900	4,150

Why split what belongs together?

Kramer – A unique system

The Kramer brand stands for all wheel steer loaders, telescopic wheel loaders and telehandlers with extreme manoeuvrability, all-terrain mobility and high efficiency. The wheel loaders impress with their high level of stability thanks to the time-tested and proven, one-piece vehicle frame.

Due to this special vehicle setup, there is no shifting of the centre of gravity through steering movements. Only the wheels move when steering due to the Ackermann steering. Thus, high stability is given even with a tight turning circle, on uneven ground conditions and with maximum payloads.

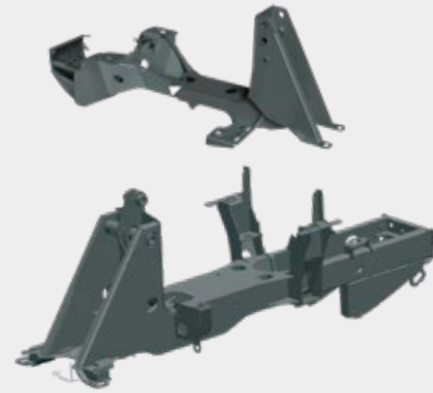

The benefits at a glance

High level of stability

The wheel loaders and telescopic wheel loaders are designed with a one-piece chassis that prevents shifts in the centre of gravity – even with a full steering lock. This makes the vehicles with a high level of stability convincing – even in uneven ground conditions.

Enormous manoeuvrability

The all-wheel steering and the steering angle of 38 degrees on the front and rear axle allow you a high degree of manoeuvrability. Some steering manoeuvres therefore become unnecessary, resulting in shorter cycle times.

Constant payload

The undivided chassis prevents the distance between the counterweight and the loader unit from changing. The result: constant leverage that makes working safe in all load situations. In the process, the payload always stays the same, self-contained of the steering angle.

Undivided chassis for a high level of stability...

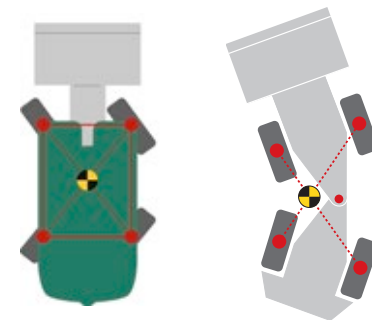

...without a shift in the centre of gravity.

Turning made easy with all-wheel steering...

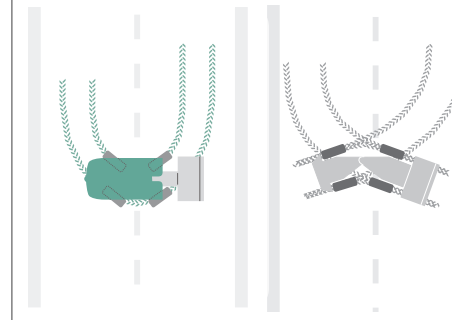

...instead of time-consuming manoeuvring with an articulated joint.

Constant leverage for constant payload

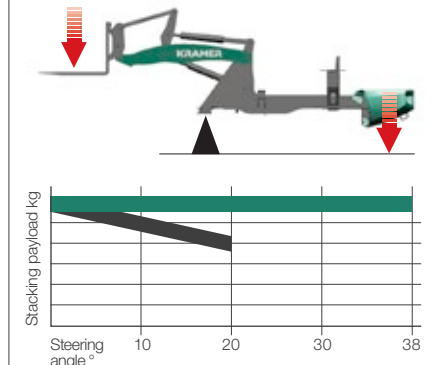

■ Kramer
■ Competition (articulated)

Flexibility in application

The right type of steering system for any application

The undivided vehicle frame forms the basis for two different types of steering. A wheel loader's design principle decides how it is used and for which application areas. The steering system is the crucial factor here.

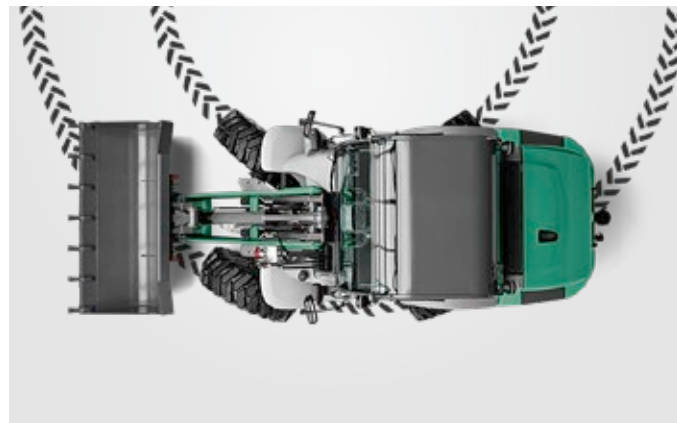

All-wheel steering

- 2 x 38 degree steering angle on the front and rear axle ensure quick work processes
- Optimised routes
- Tight turning circle



Front wheel steering*

- Safe and familiar road travel at high speed
- Easy guidance of special attachments
- Familiar steering system
- Ideal for trailer and road operation

* Optionally available for the models: KL18.5, KL19.5, KL25.5 and KL25.5T

All-wheel and articulated steering in a comparison

Example: 360° turning manoeuvre over outer edge of tyres

With the all-wheel steering, the turning circle is much smaller compared to the articulated steering (see green line). This is achieved by the steering lock on the front and rear axle, while only the front carriage moves with the articulated steering.

■ All-wheel steering

■ Articulated steering (competition)

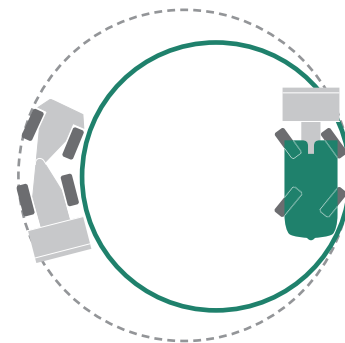

All-wheel steering is particularly manoeuvrable in tight spaces.



Front wheel steering for increased stability during transport trips.

Made for the application

Discover the product range of the compact class

The wheel loaders: KL10.5, KL12.5

Both mini-wheel loaders are the smallest Kramer models and form their own performance category. When designing and developing, the focus was on the simple and intuitive operation, which makes everyday work much easier for the operator. With its very compact design, they are great helpers when working in confined spaces. The machines are versatile in use thanks to their overall height of less than 2 m and also allow for applications inside buildings, such as working in stables. The machines can easily be transported on 3.5 tonne trailers thanks to their very low dead weight.



Technology, performance and comfort: the Kramer wheel loaders set standards.

The wheel loaders and telescopic wheel loaders: KL18.5, KL19.5, KL25.5, KL25.5T

The wheel loaders and telescopic wheel loaders of the compact class are agile in their movements, dynamic in their power delivery and slim in their design. With an optimised power to weight ratio, a low shipping weight and constantly high payload, they are the ideal helpers when it comes to stacking, loading material or feeding animals.

With the Kramer telescope technology of the KL25.5T, even greater lift heights and reaches are reached comfortably, safely and precisely. This significantly improves productivity and economic efficiency.



Top performance of the telescopic wheel loader:

+ 50% lift and dumping height

+ 42% stacking height

+ 38% load-over height

e.g. for storing straw and hay, stacking round bales, filling high-sided feed mixers or trailers



Compact dimensions and optimal power to weight ration

Power in a perfect proportion

The compact wheel loaders and telescopic wheel loaders from Kramer are among the most versatile machines on the farm. Tasks such as bale handling, silage cutting, materials handling or feeding and cleaning work can be taken care of efficiently and quickly. The machines are small enough to go anywhere and strong enough for their application.

The design principle of the undivided vehicle frame is responsible for the extremely compact dimensions. In addition, excellent power ratings are achieved from the ratio of operating weight, payload and tipping load, which are unparalleled in this vehicle class.



Compact dimensions

Low overall height and optimal overall length

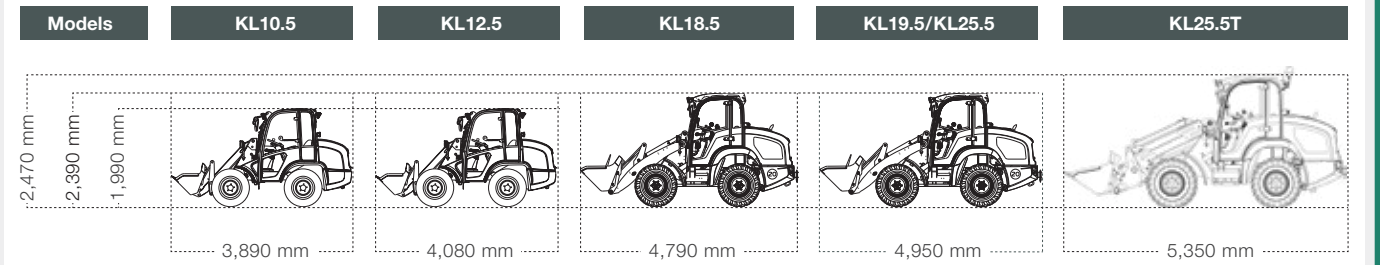

Operation data and power ratings	KL10.5	KL12.5	KL18.5	KL19.5	KL25.5	KL25.5T
Bucket capacity [m³]	0.25	0.35	0.45	0.55	0.65	0.65
Bucket tipping load [kg]	1,080	1,250	1,800	1,980	2,340	2,500
Payload on pallet forks S=1.25 [kg]	650	750	1,200	1,600	1,750	1,650/1,600
Operating weight [kg]	1,555 / 1,725*	1,620 / 1,790*	2,645 / 2,685*	3,450 / 3,600*	3,800	3,800 / 4,350*

* Cab

Top performance of the dimensions and power to weight ration:

- Perfect ratio between payload and operating weight
- Easy transport on 3.5 t trailer (KL10.5, KL12.5, KL18.5)
- Economic use that saves time and fuel thanks to the small turning radius
- Economic power to weight ratio



Low overall height of less than 2.5 m for versatile applications

A variety of tasks















Always the right attachments

Regardless of what challenges your application holds for you: with the different attachments, you will always have a handle on the situation. Thanks to the hydraulic quickhitch system, you can adapt your Kramer wheel loader to any situation in no time. Standard attachments can even be changed in less than 10 seconds.

The attachment is based on your needs. You can find out more about our attachments at: www.kramer.de/attachments



Product range of attachments

			
Pallet fork	Pallet forks, fold-down	Pallet forks, hydraulic parallel adjustment	Standard bucket with rip-out teeth
			
Standard bucket without rip-out teeth	Standard bucket without rip-out teeth with screwed-on blade	Bale spear	Round bale fork
			
Dung fork	Multifunctional fork	Silage grab bucket model A	Load hook, slip-on
			
Rotary sweeper	Snowplough model A	Snowplough model B	

Exact specifications and availabilities of attachments vary by model and country. Your competent Kramer dealer will be happy to help you.

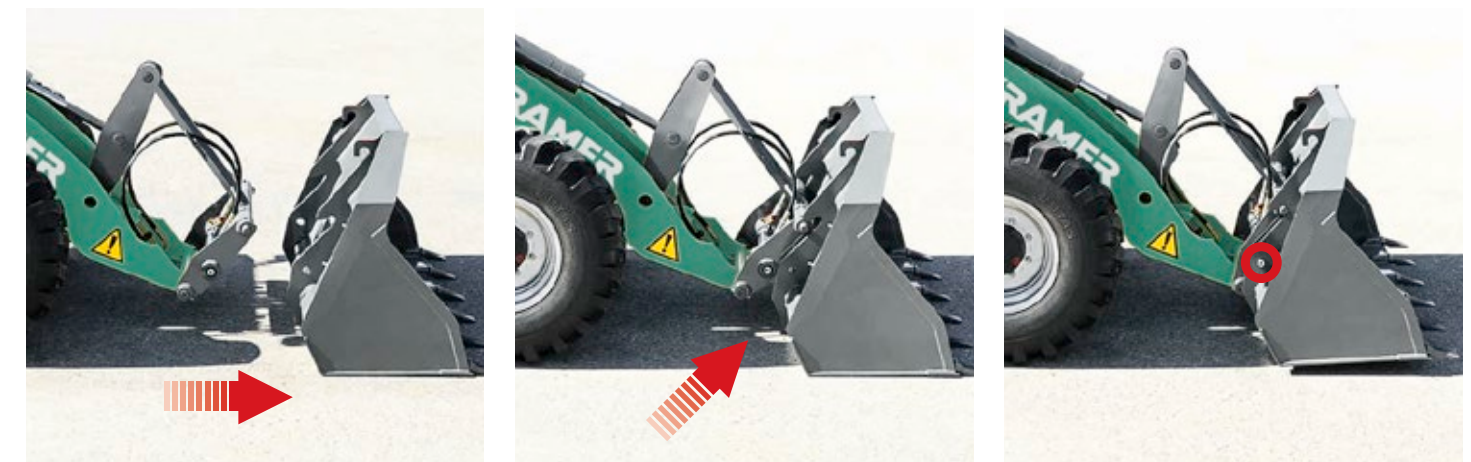

Hydraulic quick-change system - The Kramer quickhitch system: approach the attachment, pick up the attachment hydraulically from the operator's seat and lock it using the touch slide on the joystick. The lock cylinder is located above the the pivot point of the quickhitch plate and is thus not in the contamination area.

Powerful hydraulics

For sensitively controlling the machine

Connect and disconnect different attachments, sensitive control, quick work cycles and all of this with a low noise level in the cab: the technology behind the work hydraulics of our machines makes this possible.

The work hydraulics are powered by powerful gear pumps, which ensure quick work cycles of the loader unit and allow for the operation of special attachments via the 3rd control circuit, if necessary with continuous function.

Pressure release of 3rd control circuit:
easily couple and uncouple
attachments with
hydraulic additional function



Powerflow

The work hydraulics and drive system are optimally coordinated with each other. Powerflow was designed and developed for special attachments with an increased power requirement. Powerflow is optionally available and offers extra power potential.



Concept solution for system bearer	KL10.5	KL12.5	KL18.5	KL19.5	KL25.5	KL25.5T
3rd control circuit [l/min]*	20	20	56	56	56	56
Rear control circuit [l/min]*	-	40	-	-	-	-
Power flow performance hydraulics [l/min]*	-	60	-	90	90	90

*Max. pump values

Load stabiliser

The load stabiliser is optionally available and attenuates the movements of the loader unit when driving in ground conditions as well as on public roads, thereby preventing the vehicle from shaking. The ride comfort is improved and the driving safety is increased.

The load stabiliser can always be switched on or off under load for precise control. It is possible to continuously enable or disable the load stabiliser for certain applications.

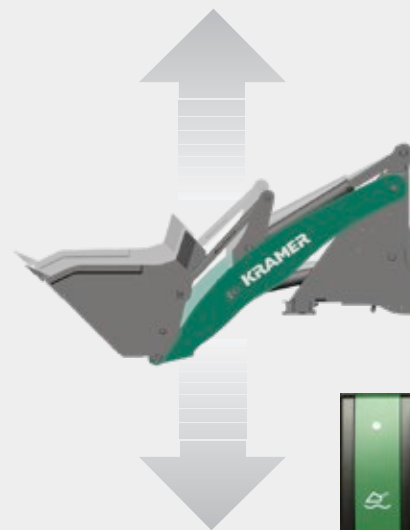

Different loader units

Work easily with large loads

Depending on requirements, three different loader units are available to you. Of course, a hydraulic quickhitch facility from Kramer with four large sized pins is offered here. The quickhitch system time-tested and proven thousands of times allows for a quick changing of attachments.

The two mini-wheel loaders KL10.5 and KL12.5 have a loader unit with Z-kinematics. The box profile design allows for the best view of the attachment and the quickhitch plate.

Z-kinematics of KL10.5 and KL12.5 :
loads are automatically kept level when
raising and lowering



Standard loader unit (P-kinematics)



The parallel-guided loader unit ensures constant lift capacity and a safe operation in materials handling. Due to the 50° tilt back angle and the tilt-out angle of 45°, the wheel loader does not lose any material in bucket application, even when it is very full, tilt out angle allows for a complete emptying of the bucket.

- Precise and safe working possible
- High tear-out forces
- Precise parallel guidance over the entire lift height

Extended loader unit (P-kinematics)



Specific customer wishes can be met even more flexibly due to the extended loader unit. Among other things, the range, payload and lift height change compared to the standard loader unit.

- Optimal view of the quickhitch facility and the attachment
- Increased lift height
- Extension of the loader unit by 190 mm (KL19.5, KL25.5)

Telehandler system (Z-kinematics)



The view of the attachment is exceptional thanks to the compact modular design of the telehandler system. The advantages of Z-kinematics: in the case of equal size cylinders, Hydraulic ram positioning creates a higher tearout force since pressure is applied to the piston side of the hydraulic cylinder when filling the bucket.

- High tear-out forces
- Good view of the quick coupler frame and the attachment
- Additional load-over and stacking height as well as range and dumping width

Machine highlights of the KL10.5 / KL12.5

The compact genius among wheel loaders

Excellent performance values
with compact dimensions and low dead weight.

Loader unit with Z-kinematics:
for high lift capacities and tear-out forces and an exact parallel guidance over the entire lift height.

Work efficiently
thanks to the hydraulic quickhitch system and load stabiliser.

Flexible in application
with a standard 3rd control circuit.
The optional Powerflow for the KL12.5 adds a powerful drive to the hydraulic attachments.

Large selection of tyre options
for a wide range of application areas.

Undivided vehicle frame with all-wheel steering
for extreme manoeuvrability and a high level of stability.

Canopy version (open cabin)
is available as a standard. Functionality and ergonomics are the focus here. An enclosed cabin for the KL12.5 is optionally available.

Compact dimensions
thanks to a vehicle width of 1.20 m and a vehicle height of less than 2 m.

Powerful engines
from Yanmar for a performance-adjusted engine version and an economical cost ratio. A 27 kW engine is optionally available for the KL12.5.

Four wheel hub motors
for sensitive work and high pushing power.

Excellent traction
thanks to the optional 100% connectable differential lock for the KL12.5.

Powerflow



Load stabiliser



Wheel hub motor



Differential lock



Machine highlights of the KL18.5 - KL25.5T

Sturdy on the outside and intelligent on the inside

Smart Ballast (KL18.5)



Powerflow



High speed



End position damping (KL25.5)



The hydraulically activated quickhitch facility makes the Kramer an all-rounder in seconds without leaving the operator's seat. Efficient work with a parallel-guided loader unit with P-kinematics for wheel loaders and with Z-kinematics for the telescopic wheel loader.

More reach and lift height due to a telescoping loader unit.

Reduced operating costs through optimum power to weight ratio and compact dimensions.

Fatigue-free work thanks to the spacious and ergonomic cabin, which is installed as a standard (KL25.5) or optionally.

Gentle retraction and extension thanks to the final position dampening in the retract and extension.

High reliability through easily accessible maintenance points and time-tested and proven components.

High bucket apron, long bucket bottom as well as a large tilt in and tilt back angle for a safe and quick material transport with high volumetric efficiency.

Smart Ballast (KL18.5) easily and quickly adjust the payload and weight of the machine.

Flexible in application with a 3rd control circuit, unpressurised return flow with drain line and front outlet.

Variable drive system - with two types of steering (all-wheel steering and optional front wheel steering) and up to 30 km/h.

Wide and safe entry thanks to the undivided vehicle frame and all-wheel steering for enhanced stability and manoeuvrability.

Excellent traction thanks to 100% connectable differential lock in the front axle (option for KL18.5, KL19.5) and the right tyres for every application.



Working comfortably

For ideal working conditions

Simple operation and functionality are the focus of the machine series. From the operator's seat to the steering wheel, all detail where consequently aligned with the needs of the operator. The operator has plenty of room and everything is always in view here.

The compact wheel and telescopic wheel loaders from Kramer have proven to be real space miracles in terms of cabin technology and their equipment ensures fatigue-free working for many hours. The clearly arranged operator's controls create an environment in which the operator's controls can work comfortably, focused and productively. The joystick, as the heart of the machine, provides secure, simple and intuitive operation.

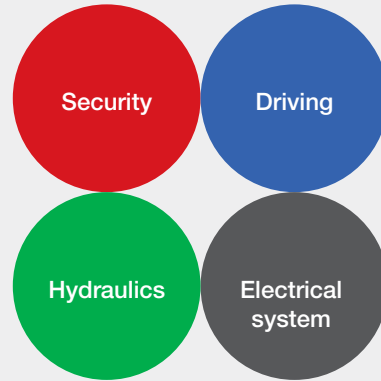

Colour-coding of the switches:
four colours for even more safety.



Panoramic cabin for an excellent overview of the attachment and the working environment.

Technical highlights

Simple operation – Innovative cabin design

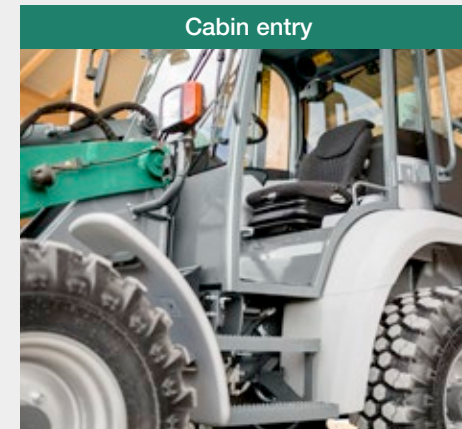

The cabin can be accessed through the large entry area. The undivided vehicle frame also makes it possible to comfortably enter at maximum steering lock. The entry is designed like steps. The grab handles are in an ergonomically favourable position to guarantee the operator a safe entry and exit.

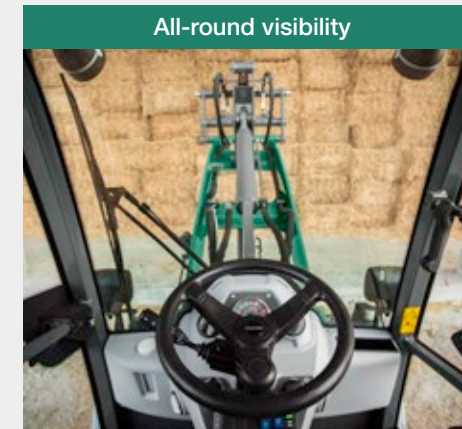

The central seat position of the operator offers a 360° all-round visibility. "Blind spots" are avoided thanks to the particularly clearly arranged design. You can even see everything to the rear. Even when the telehandler system is extended on the KL25.5T, the operator has a perfect view of the attachment.



The joystick shows its strengths above all when things get dark. In the night design, the different touch buttons and wheels light up in different colours. The operator can then immediately identify the respective function and his vehicle is safely under control. The control lever for the 3rd control circuit follows the tilt-in and tilt-out movement of the joystick.

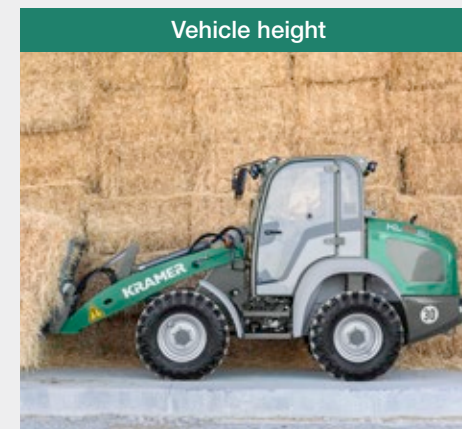

The machines offer the best previous conditions for low headrooms. The compact and low design of the wheel loaders and telescopic wheel loaders of less than 2.50 m allows for the ideal application of the machines in confined farm yards and stables.

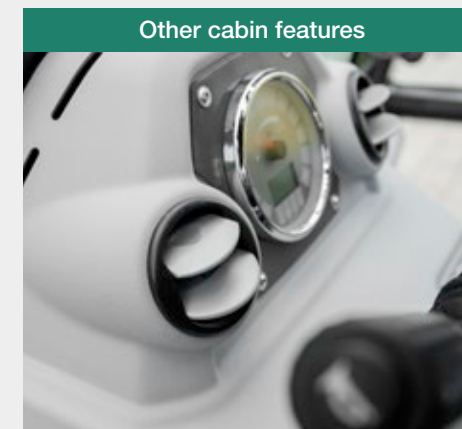

The combined brake-inch pedal allows for precise manoeuvring, even at high engine speed. The powerful heater with window ventilation and heating nozzles in the footwell ensures comfortable working, even on cold days. A fully integrated air-conditioning system is optionally available.*

* not for KL10.5 and KL12.5



The respective functional group is very quick and easy to identify due to the colour-coded switches. Red = safety, green = hydraulics, blue = travel and grey = electrical system. This ensures the operator a convenient and safe operation without the risk of being confused. The result is increased working efficiency for the operator.

Powerful engines

Efficient fuel consumption

Both mini wheel loaders KL10.5 and KL12.5 have a 23 kW Yanmar engine as a standard. In addition, the KL12.5 model is available with an optional 27 kW engine. Both engines meet the exhaust emission stage IIIA.

The models KL18.5 to KL25.5T are also equipped with Yanmar engines. The engines with 34.3 kW (standard) and 41.1 kW (option for KL19.5, KL25.5, KL25.5T) have a diesel oxidation catalytic converter (DOC) and diesel particle filter (DPF), thereby fulfilling the exhaust level V. The engines offer full performance, despite a low rpm and a high torque increase.

Top performance of the engines:

- performance-adjusted engine version with an economical cost ratio
- modern exhaust aftertreatment with DOC + DPF
- optional engines with increased performance available

Overview of engines	KL10.5	KL12.5	KL18.5	KL19.5	KL25.5	KL25.5T
	Standard	Standard (Option)	Standard	Standard (Option)	Standard (Option)	Standard (Option)
Engine manufacturer	Yanmar	Yanmar	Yanmar	Yanmar	Yanmar	Yanmar
Output [kw/hp]	23/31	23/31 (27/37)	34.3/46	34.3/46 (41.1/55)	34.3/46 (41.1/55)	34.3/46 (41.1/55)
Exhaust aftertreatment system	-	-	DOC+DPF	DOC+DPF	DOC+DPF	DOC+DPF
Exhaust fumes level (EU exhaust fumes standard)	Level IIIA	Level IIIA	Stage V	Stage V	Stage V	Stage V



Optimised running smoothness: economical and powerful engines in all Kramer models.

Exhaust fume aftertreatment systems

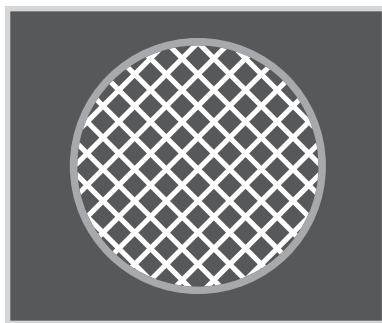

Diesel oxidation catalytic converter (DOC)

Catalytic converters are used these days to reduce emissions in many cars and lorries. The diesel oxidation catalytic converter has the same functionality. Without the movement of mechanical parts, it triggers chemical processes that reduce emissions.

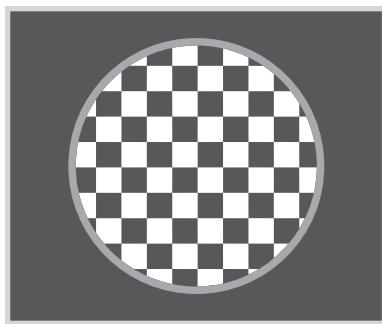

Diesel particle filter (DPF)

The diesel particulate filter is used in connection with an oxidation catalytic converter to remove most of the nitrogen oxides, soot particles and non-combusted hydrocarbons from the combusted diesel fuel. The diesel particulate filter contains a porous honeycomb structure that catches the soot when it passes through. When the soot has accumulated to a certain extent, the machine's electronic system triggers fuel injections, which brings the non-combusted fuel into the oxidation catalytic converter, which is located before the filter. There it triggers an exothermic reaction that heats the exhaust fumes so much that the soot in the diesel particulate filter is combusted. This process is also known as regeneration.

Performance curve of Yanmar 3TNV88; 24.1 kW; stage IIIA (standard)

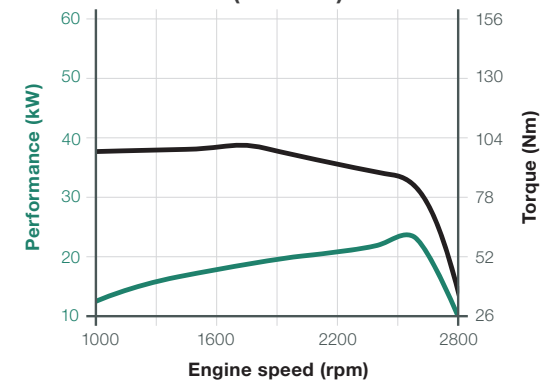

Performance curve of Yanmar 3TNV84; 26.7 kW; stage IIIA (option)

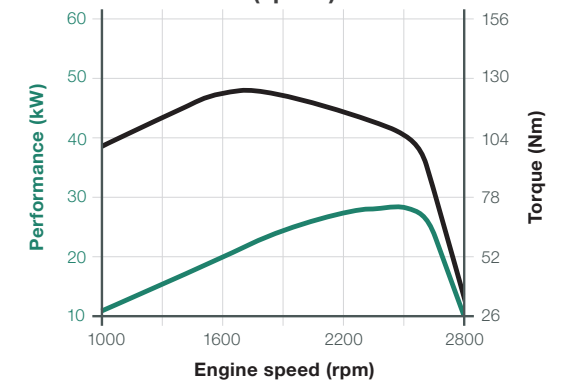

Performance curve of Yanmar 4TNV88C; 34.3 kW; stage V (standard)

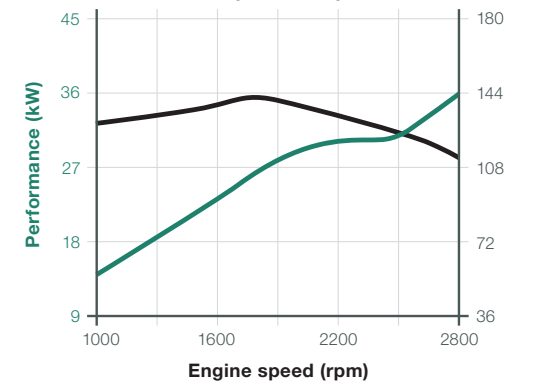

Performance curve of Yanmar 4TNV86CT; 41.1 kW; stage V (option)

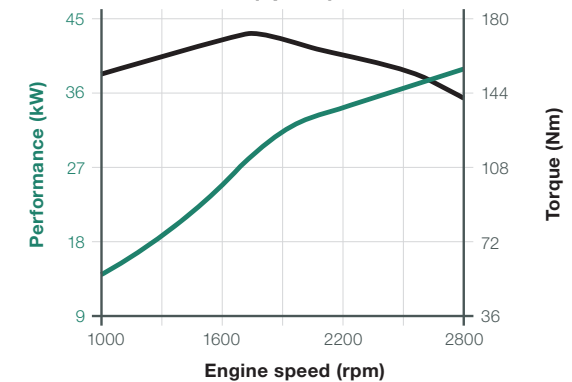

Time-tested and proven drive system

Always safely on the go

Wheel loader: KL10.5, KL12.5

The machines are driven by four wheel hub motors that achieve an incomparable dynamics and allow for a very compact design. At the same time, the centre of gravity sits lower, which in turn increases stability of the machines. The degree of efficiency of the drive with the four wheel hub motors also provides for a high degree of flexibility of the vehicle for quick work cycles.



Wheel loaders and telescopic wheel loaders: KL18.5, KL19.5, KL25.5, KL25.5T

A variable, hydrostatic axial piston transmission provides for a powerful and variable driving behaviour with a travel speed from 0 to 20 km/h (optionally up to 30 km/h). The speed and pushing power are thus perfectly coordinated. In addition, movements accurate down to the millimetre can be made very gentle and jerk-free.



Top performance of the drive system:

- variable hydrostatic high-speed gearbox
- maximum pushing power and tractive force in all driving and working situations
- low noise level and reduced consumption thanks to the demand-oriented coordination of the drive system and engine version
- traction on every surface due to various tyre options and the differential lock

Two freely selectable speed levels

The speed levels can be easily changed while driving. The change occurs conveniently through a switch on the dashboard. The symbol is shown immediately in the central digital display.

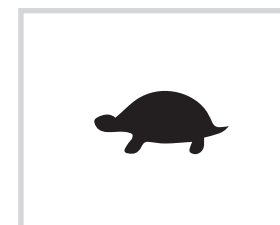

Turtle: 0 - 5 km/h

Available with
• Hydrostat

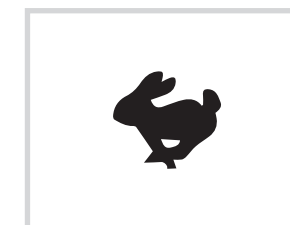

Hare: 0 - 20 (30 km/h)*

Available with
• Hydrostat
(maximum speed
20 or 30 km/h)

* High-speed engine

Tyre product range



- High running performance
- High level of traction
- Good mobility on soft ground
- Good self-cleaning

Construction machine tread - Continental
KL10.5, KL12.5



- Good winter serviceability
- High running performance
- Noise-optimised
- For applications on and off of the road

Municipal tread - Continental
KL10.5, KL12.5



- Good self-cleaning
- Ideal for loamy ground
- High level of traction
- Smooth running on the road

Traction tread - Mitas Premium
KL18.5 - KL25.5T



- Good self-cleaning
- Good flank protection
- High running performance

Universal tread - Mitas
KL10.5, KL12.5



- High running performance
- Good self-cleaning
- Good mobility on soft ground
- High level of traction

Traction tread - Alliance
KL18.5 - KL25.5T



- Smooth running on the road
- Good resistance
- Well-suited in sand and gravel

Multi-purpose tread - Alliance
KL18.5 - KL25.5T



- Good track guiding
- High level of driving safety
- Good self-cleaning
- High running performance

Traction tread - Mitas
KL10.5, KL12.5



- High lift capacity
- High level of traction
- Excellent stability and improved driving comfort
- High level of running smoothness

Multi-purpose tread - Michelin
KL18.5 - KL25.5T



- High level of traction
- Well-suited in sand and gravel
- Good resistance

Multi-purpose tread - Nokian
KL18.5 - KL25.5T



- Good self-cleaning
- Good lateral stability
- High running performance, especially when used on hard and aggressive substrates
- High level of traction

Industrial tread - Michelin
KL10.5 - KL12.5



- Good resistance
- Smooth running on the road
- High level of traction
- For applications on and off of the road

Multi-purpose tread - Mitas
KL18.5 - KL25.5T

Choosing the right tyres is crucial when it comes to using your wheel loader. Exact tyre specifications and availabilities vary by model and country. Your competent Kramer dealer will be happy to help you.



Top Performance

Telescopic wheel loaders

- extra 50% lift height and dumping height
- extra 42% stacking height
- extra 38% load-over height

e.g. for storing straw and hay, stacking round bales, filling high-sided feed mixers or trailers

Dimensions and power to weight ration

- perfect ratio between payload and operating weight
- easy transport on 3.5 t trailer (KL10.5, KL12.5, KL18.5)
- economic use that saves time and fuel thanks to the small turning radius
- economic power to weight ratio

Loader unit

- load stabiliser for more driving comfort and safety
- more flexibility thanks to different loader units
- a thousand-time-tested and proven quickhitch system for the quick application of different attachments
- ideal bucket geometry for optimal handling of bulk material

Engine

- performance-adjusted engine version with an economical cost ratio
- the latest exhaust aftertreatment with DOC + DPF
- optional engines with increased performance available

Drive

- variable hydrostatics high-speed gearbox
- maximum pushing power and tractive force in all driving and working situations
- low noise level and reduced consumption thanks to the demand-oriented coordination of the drive system and engine version
- traction on every surface due to various tyre options and the differential lock

Technical Data

Engine	Unit	KL10.5	KL12.5	KL18.5	KL19.5	KL25.5	KL25.5T
Make	–	Yanmar	Yanmar	Yanmar	Yanmar	Yanmar	Yanmar
Type/Model	–	3TNV88	3TNV88 (standard) 3TNV84 (option)	4TNV88C	4TNV88C (standard) 4TNV86CT (option)	4TNV88C (standard) 4TNV86CT (option)	4TNV88C (standard) 4TNV86CT (option)
Output	kW	23	23 (series) 27 (option)	34.3	34.3 (series) 41.1 (option)	34.3 (series) 41.1 (option)	34.3 (series) 41.1 (option)
Max. torque	Nm at rpm	107 at 1,560	107 at 1,560 124 at 1,560 (option)	140.4 at 1,820	140.4 at 1,820 167 at 1,820 (option)	140.4 at 1,820 167 at 1,820 (option)	140.4 at 1,820 167 at 1,820 (option)
Displacement	cm ³	1,642	1,642 (series) 1,496 (option)	2,190	2,190 (series) 2,091 (option)	2,190 (series) 2,091 (option)	2,190 (series) 2,091 (option)
Exhaust emission stage	–	EU level IIIA	EU level IIIA	EU level V	EU level V	EU level V	EU level V
Power transmission	Unit						
Drive	–	Variable, hydrostatic drive system					
Travel speed	km/h	20	20	20 (series) 30 (option)	20 (series) 30 (option)	20 (series) 30 (option)	20 (series) 30 (option)
Axles	–	Axle carrier made of cast steel with wheel hub motors		Planetary steering axle	Planetary steering axle	Planetary steering axle	Planetary steering axle
Total oscillation angle	°	7	7	8	8	8	8
Differential lock	%	-	Compensation differential hydraulic	100% (option FA)	100% (option FA)	100% FA	100% FA
Service brake	–	Hydrostatically	Hydrostatically	Hydr. disc brake		Hydr. disc brake	
Parking brake	–	Spring-loaded multi-plate braking system, electro-hydraulically controlled		Mech. disc brake		Mech. disc brake	
Standard tyres	–	28x9.00-15	28x9.00-15	10.5-18	10.5-18	12.0-18	12.0-18
Steering and work hydraulics	Unit						
Steering system functionality	–	Hydrostatic all-wheel steering with emergency steering properties Front wheel steering (option)					
Functioning of work hydraulics	–	Gear pump					
Steering pump	cm ³ /rev	8	8	20	20	20	20
Steering cylinder	–	Double-acting, with automatic synchronisation in final position					
Steering lock max.	°	38	38	38	38	38	38
Work pump	cm ³ /rev	8	8	20	20	20	20
Max. flow rate of pump	l/min	20	20	56	56	56	56
Max. flow rate of pump optional	l/min	-	40/60	90	90	90	90
Max. pressure	bar	240	240	240	240	240	240
Quickhitch system	–	Kramer					
Pilot operation	–	Hydraulic					
Pilot control of 3rd control circuit	–	Electrical					

Technical Data

Kinematics	Unit	KL10.5	KL12.5	KL18.5	KL19.5	KL25.5	KL25.5T
Design system	–	Z-kinematics	Z-kinematics	P-kinematics	P-kinematics	P-kinematics	Z-kinematics
Lifting force calculation as per ISO 14397-2 hydraulic	kN	12.9	12.9	37	32.5	32.5	32.5
Tearout force calculation as per ISO 14397-2	kN	13.1	13.1	31.7	28	28	28
Lift cylinder raising/lowering	s	6.0/4.3	6.0/4.3	4.6/2.9	4.8/3.2	4.8/3.2	6.7/5.0
Tilt in/tilt out tilt cylinder (upper position of the loader unit)	s	2.4/1.5	2.4/1.5	2.6/3.1	2.1/2.0	2.1/2.0	3.5/3.0
Tilt-in / tilt-out angle	°	40/45	40/45	45/40	45/42	45/42	30/40
Tippling load (standard bucket) actual	kg	1,080	1,250	1,800	1,980	2,340	2,500
Tippling load (pallet forks)	kg	810	935	1,500 (1,700)*	2,000	2,187	2,060
Payload (pallet forks) S=1.25	kg	650	750	1,200 (1,360)*	1,600	1,750	1,650
Capacities	Unit						
Fuel tank	l	30	30	60	60	60	60
Hydraulic oil tank	l	40	40	58	58	58	58
Electrical system	Unit						
Operating voltage	V	12	12	12	12	12	12
Battery / alternator	Ah/A	72/55	72/55	74/80	74/80	74/80	74/80
Starter motor	kW	2.3	2.3	2.3	2.3	2.3	2.3
Noise emissions**	Unit						
Measured value	dB(A)	99.7	99.7	100.3	100.3	100.3	100.3
Guaranteed value	dB(A)	101	101	101	101	101	101
Noise level at the operator's ear	dB(A)	82	82	79	79	79	79
Vibrations***	Unit						
Vibration total value of the upper extremities of the body	m/s ²	< 2.5 m/s ² (< 8.2 feet/s ²)					
Maximum weighted average effective value of acceleration for the body	m/s ²	< 0.5 m/s ² (< 1.64 feet/s ²)**** 1.28 m/s ² (4.19 feet/s ²)*****					

* With Smart Ballast (8 x 12.5 kg)

** Information: the measurement occurs as per the requirements of the standard EN 474 and the directive 2000/14/EC. Measuring station: paved surface.

*** Uncertainties of measurement as specified in ISO/TR 25398:2006. Please instruct or inform the operator of possible dangers caused by vibrations.

**** On flat and solid ground with the corresponding driving style

***** Application in extraction under harsh environmental conditions

Dimensions

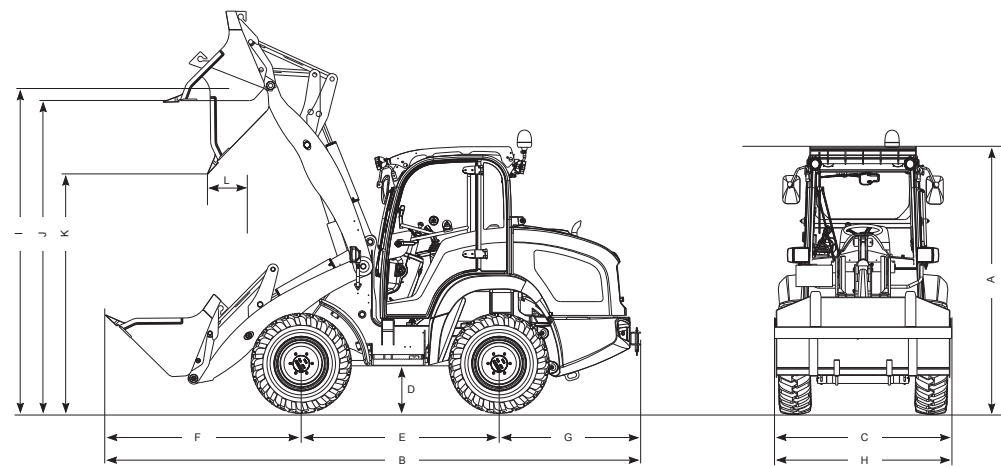

Standard equipment with standard bucket		Unit	KL10.5	KL12.5	KL18.5	KL19.5	KL25.5	KL25.5T
A	Height*	mm	1,980	1,980	2,390	2,390	2,390	2,470
B	Length	mm	3,890	4,080	4,790	4,950	4,950	5,350
C	Width*	mm	1,200	1,200	1,590	1,590	1,595	1,595
D	Ground clearance	mm	230	230	280	280	280	280
E	Wheel base	mm	1,525	1,525	1,850	1,850	1,850	2,000
F	Centre of front axle to tip of teeth	mm	1,360	1,360	1,620	1,780	1,780	1,992
G	Centre of rear axle to end of vehicle	mm	1,195	1,195	1,320	1,320	1,320	1,320
H	Bucket width	mm	1,250	1,250	1,650	1,650	1,650	1,650
I	Bucket swivel point	mm	2,800	2,800	2,840	3,050	3,050	4,270
J	Load-over height	mm	2,690	2,690	2,610	2,890	2,900	4,010
K	Dumping height	mm	2,260	2,260	2,080	2,320	2,330	3,500
L	Dump reach	mm	165	165	270	315	315	810
-	Stacking height	mm	2,680	2,680	2,600	2,950	2,950	4,030
-	Turning radius (via tyres)	mm	1,950	1,950	2,700	2,700	2,700	2,900

Standard equipment with standard bucket		Unit	KL19.5L	KL25.5L
A	Height*	mm	2,390	2,390
B	Length	mm	5,140	5,140
C	Width*	mm	1,590	1,595
D	Ground clearance	mm	280	280
E	Wheel base	mm	1,850	1,850
F	Centre of front axle to tip of teeth	mm	1,970	1,970
G	Centre of rear axle to end of vehicle	mm	1,320	1,320
H	Bucket width	mm	1,650	1,650
I	Bucket swivel point	mm	3,300	3,300
J	Load-over height	mm	3,150	3,150
K	Dumping height	mm	2,650	2,650
L	Dump reach	mm	410	410
-	Stacking height	mm	3,200	3,200
-	Turning radius (via tyres)	mm	2,700	2,700

* With standard tyres

Load-bearing capacity diagram

KL25.5T (cabin)

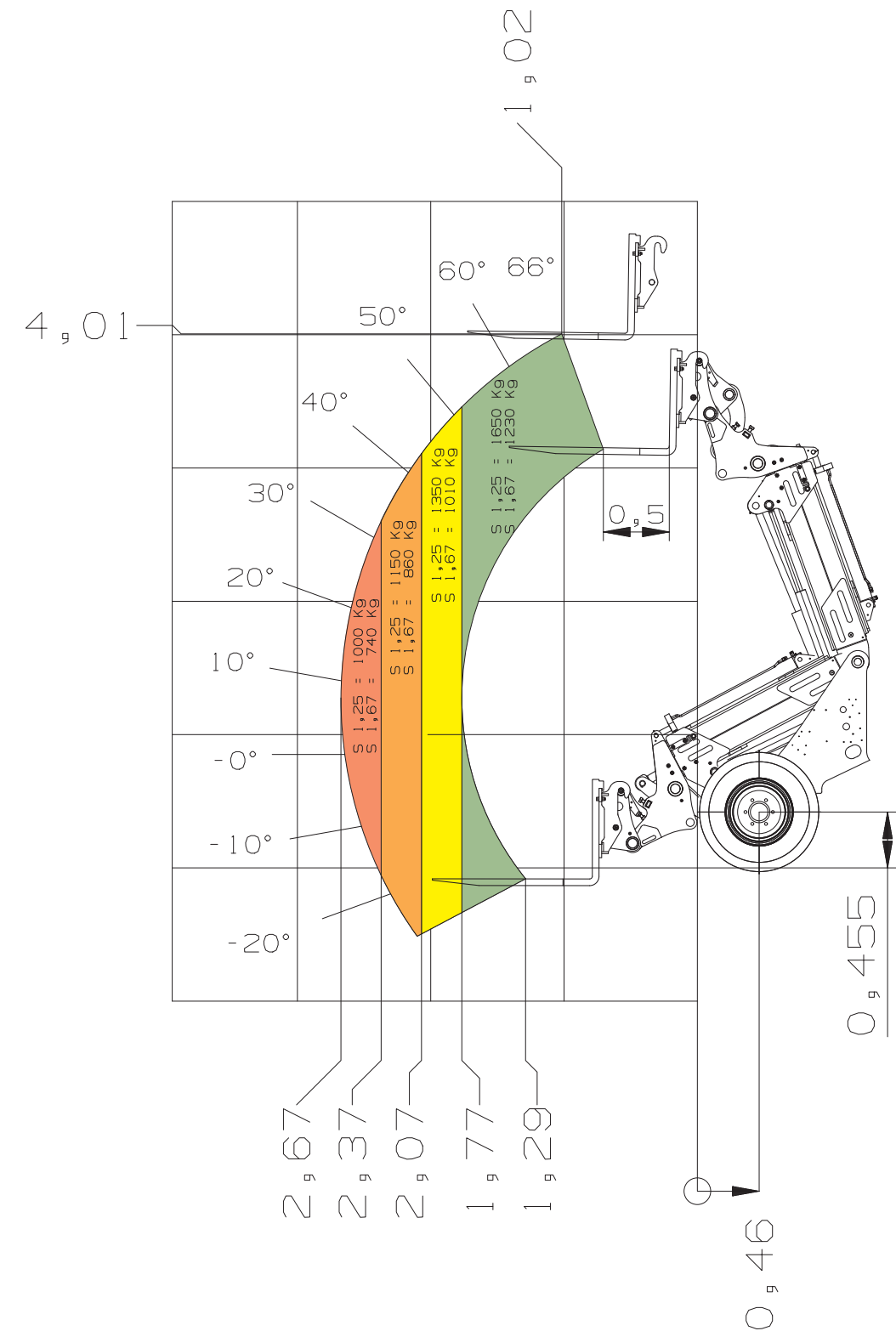



Wheel loader

Tipping load: 1,000 - 7,000 kg



telescopic wheel loaders

Tipping load: 2,500 - 5,500 kg



Telehandler

Payload: 2,700 - 5,500 kg

Service that can be seen

Focus on your daily activities – with our comprehensive services, we take care of the rest. We are there when you need us: capable, fast, and directly on site if necessary.



Repair & maintenance



Academy



Telematics



Insurance



Spare parts



Financial Solutions



KA.EMEA.10204.V03.EN-GB