

HSM 405H2 8WD



Engine:

- IVECO
- NEF 6 Zyl. Common Rail Turbo/ EuroMot TIER3
- Power: 175 kW / 238 HP
- max. revolution: 2200 rpm
- max. torque: 1020 Nm at 1500 rpm
- Displacement: 6,7 Liter

Power Train:

- Hydrostatic-mechanically
- Elektronisch control CMC
- NAF 2-speed transfer case
- Traction force 175 kN

Axles:

- NAF balanced Portal-Bogie-Axles
- Front: Switchable differential lock 100%
- Rear: Switchable differential lock 100%

Brake:

- Brake with 2-circles, oil-cooled multiple-disc powerbrake
- Spring-loaded power parking-brake

Steering:

- Articulated frame steering
- 2 steering cylinders
- Steering angle 52°

Tires:

- | | Size: | Overall width |
|------------|-------------|---------------|
| • Serial | 710/45-26,5 | 2880 mm |
| • Optional | 800/40-26,5 | from 3180 mm |
| | 600/55-26,5 | from 2780 mm |
| | 54x37-25 | 3520 mm |

Fuel-Tank:

- Capacity: 460 Liter

Hydraulic system:

- Load Sensing
- Variable pump: 1 x 145 ccm / 1 x 190 ccm
Pump flow: 469 l/min at 1400 rpm
Pressure: up to max. 380 bar
- Gear pump:
Pump flow: 15,4 l/min at 1400 rpm
Pressure: 120 bar
- Tank: 240 Liter
- Hydraulikoil: unsaturated, synthetic ester
Panolin HLP SYNTH mit Kleenoil
Microfiltration WGK 1
- Valve-block: Danfoss PVG 32
- Crane-control: Digital electronics CMC with individual adjustable speed and ramp times, 5 driver programs

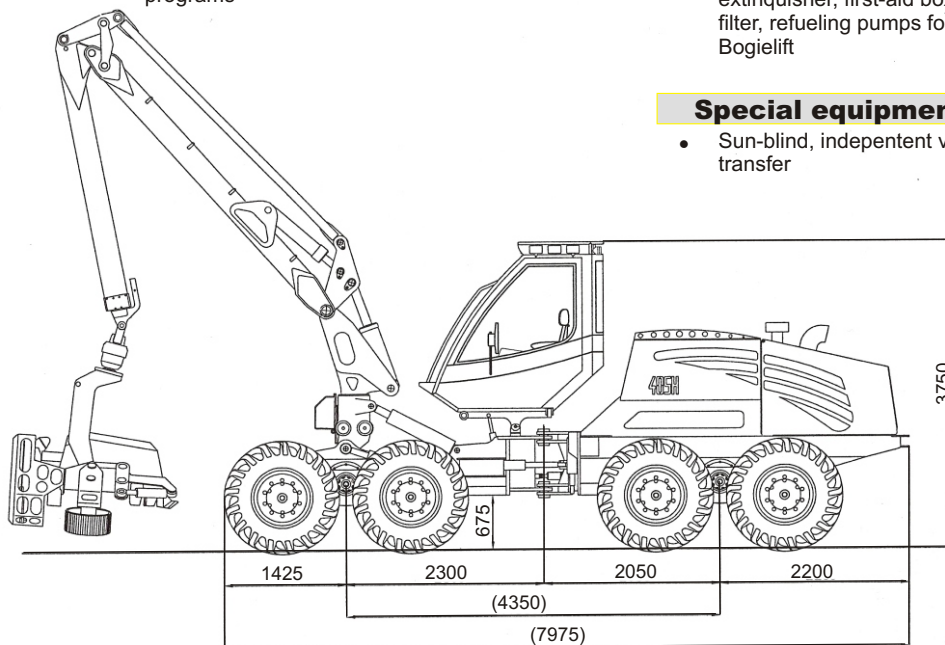

Elektrical system:

- Generator 24V, 2 x 90A
- 2 service-free dry batteries each with 75A

Cabin:

- Tilttable cabin forward / reverse
- Curved windscreen Lexan
- Protection tested conforming with ROPS ISO 8082
- Wiper in front and on the side
- Comfortable, air cushioned seat
- Warm water heater
- Air-conditioning

Gauges:

- Fuel-Tank gauges, cooling water temperature, alphanumeric display for rpm, speed, hydraulic oil-temperature, as well as all process data for driving and working hydraulics, warning overhead engine

Weight:

- 19500 kg (serial)

Central oscillation lock:

- 2 Hydraulic cylinders

Crane:

- | | |
|----------------------|----------|
| • Loglift L220 V100 | |
| Reach | 10 m |
| Lifting moment gross | 188 kNm |
| Slewing torque | 43,6 kNm |

Harvester Head:

- | | |
|-----------------------------------|---------|
| • Serial: | |
| Waratah H480 | |
| Felling diameter | 710 mm |
| Delimiting diameter | 480 mm |
| Feed force with 630/400 ccm motor | 23,7 kN |
| Feed force with 800/500 ccm motor | 30,2 kN |
| Feed speed | 5,0 m/s |
| Operating pressure max. | 280 bar |
| Weight | 1250 kg |

Alternate harvester heads on request.

Control system:

- | | |
|------------|----------------------|
| • Serial | Motomit IT |
| • Optional | Motomit PC
DASA 4 |

Standard equipment:

- 19 x spotlamps Twin Power each 2x70W mounted on cabin, 4 spotlamps in front of crane, potential transformer, radio, fire extinguisher, first-aid box, warning triangle, tool kit, bypass-filter, refueling pumps for fuel and hydraulic oil, vacuum pump, Bogielift

Special equipment:

- Sun-blind, independent vehicle heater, GPS-system, data transfer

Technical subject to change
April 2008
P-Nr: 405H2-8WD-engl-TB003