

HIDROMEK

HMK
140 LC
GEN





HEAVY DUTY TYPE

HMK 140 LC has been designed by HIDROMEK engineers after careful evaluation of working conditions and operator demands and has been released on the market following as a crawler excavator that meets all expectations of users. All fabricated parts including boom, arm, bucket, undercarriage, lower and upper frames have been designed and produced as heavy duty type. HMK 140 LC offers its operator maximum efficiency by providing trouble-free and continuous operating performance even in the toughest of working conditions. When such rigorous care at the design stage of HMK 140 LC is combined with worldwide approved components and state-of-the-art production technologies, the outcome has been a high performance, durable, comfortable, and well-balanced product with low maintenance and operation costs.

CAB

HMK 140 LC excavator cabin has been designed to allow the operator to work comfortably even under the hardest conditions.

The cab door is large enough to enable the operator to open it easily plenty of clearance. Opening windscreen is designed to give the operator a perfect angle of vision. It is possible to open the windscreen by sliding it towards the roof and windscreen. Rear window may be removed and kept under the operator seat. Other features enhancing operator's comfort are the ergonomic seat and front console. The standard operator seat of the HMK 140 LC can be adjusted in 9 different positions and is designed to enable operator to work without fatigue and comfortably with high performance for long hours.. Besides, the joystick console and seat can move independently enabling operator to adjust the most suitable position for his body structure.

The seat is equipped with seat belt for safety of the operator. The cab is supported by 6 silicon viscose mounts that dampen the effects of noise, shock and vibrations regardless of working conditions of the machine and the optional attachment on it. Also an air conditioner is included in the standard equipment.



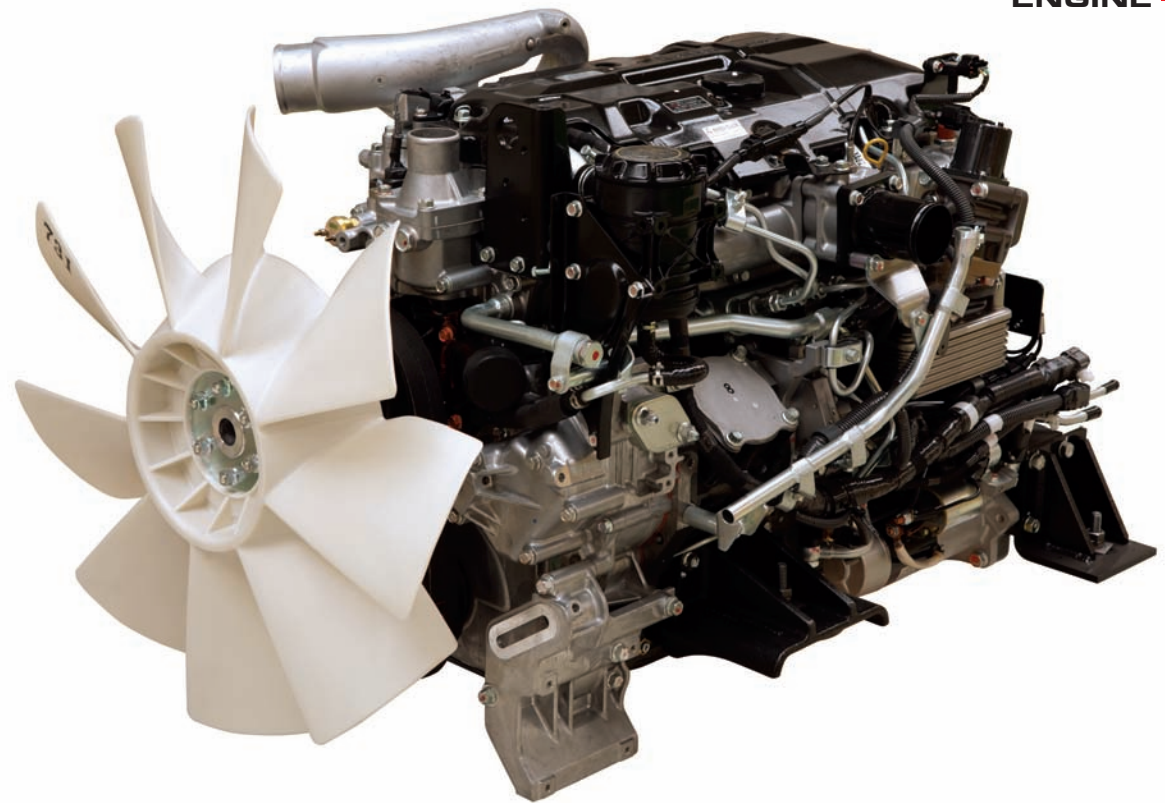

“An Extraordinary Engine”

Diesel Engine

Max Power (SAE J1349) : 124 HP (92.5 kW) 2000 rpm
Max Torque : 484 Nm 1600 rpm

An extraordinary engine...

The Mitsubishi engine fitted in the HMK 140 LC is specially developed for excavator applications. It is a turbo diesel engine, complies with the Emission Regulations U.S EPA Tier III and EU Stage IIIA, with 4 cylinders, 4 cycles, water-cooling, turbocharger and intercooler. High performance, long life and reliability of the engine under all working conditions have been proved in many different markets.

Low fuel consumption...

The direct fuel injection and intercooler feature not only provide less fuel consumption but also increase the power and torque produced by the engine by providing more efficient combustion.

More than standard...

Hidromek always offers more than what is expected from any construction equipment. Some of the standard features offered along with HMK 140 LC model are:

- Air pre-heating function to start-up engine easily in cold weather conditions
- Diesel fuel/water separator
- No disturbance for the environment and operator due to low exhaust gas emission and sound level.

“Reinforced Heavy Duty Type Construction”



X' box type sub-frame

'X' shape box type sub-frame has perfect resistance against bending forces and vibration stress since it homogeneously distributes the stress exposed on it.

Resistance

The lower rollers are connected on the pentagon linkages on the sub-frame which enhance the strength and lifetime of the frame. Latest technology production techniques under firm quality control make “zero” error production possible.

The standard long track maximizes the balance of the machine by providing an enduring platform for the machine to work on. Two roller housings in each track keep track chains in straight direction and therefore prevent wearing of lower rollers.

The upper rollers, lower rollers and front idlers are suitable to work on all kinds of terrain and they have been sealed with life-time seals. This maintenance-free structure has been a solution for heavy duty work.

Track pins and bushings are greased and sealed, thus reducing chain noise and extending track life.

Triple grouser track links with triple grouser are able to self-clean through their holes.

Opera Control System

- Perfect control
- Fuel economy
- Long component life
- Low noise level and exhaust gas emission
- Operator comfort
- Warning and protection (security) features
- Malfunction / fault indication feature
- Auxiliary functions

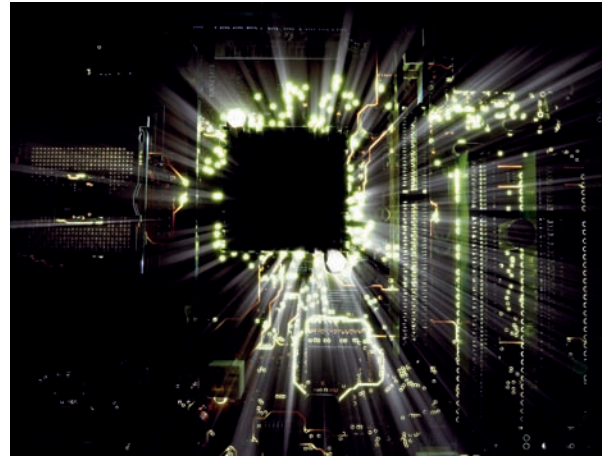

Opera Control System ,consists of 4 power mode and 3 work modes, introduces operator most suitable working conditions in accordance with requirements of work with high performance and economic working options through perfect matching with diesel engine and hydraulic pump.

- Audible warning
- Warning lights
- Indicators

MODE SELECTIONS

A-Power Mode Selection

POWER MODE	
F (Sensitive Mode)	This mode is used for light works requiring sensitive movements
E (Economy Mode)	This mode is for light work in which low fuel consumption is desired.
P (Power Mode)	This mode is for general digging and loading works.
HP (High Power Mode)	This mode is for heavy and high speed required works. It is suitable for when productivity is considered

B- Working Mode Selection

WORKING MODE	
D (Digging Mode)	It is designed for normal digging operations.
B (Breaking Mode)	It is designed for breaking operations.
O (Optional attachment Mode)	It is designed to work with optional attachment.

WARNING AND PROTECTION FEATURES

Continuous Monitoring:

Opera Control System, continuously monitors most important parameters of machine and promptly warn operator in case of any abnormality. Such warning can be in three ways:

Overheating Prevention Function:

If engine water temperature and hydraulic oil temperature exceeds certain temperature , electronic control system provides continuous work by decreasing pump flow rate and engine rpm .

Automatic preheating :

Automatic preheating provides reaching machine to optimum working temperatures by measuring air intake temperature , cooling water temperature and hydraulic oil temperature of diesel engine. Machine control unit removes engine rpm from idling to 1200 rpm when engine cooling water is lower than 30°C or hydraulic oil temperature is lower than 0°C and stay on this rpm until warm up . By this way early wearing of main components beginning engine in the first place is prevented. However if there is emergency and machine is required to be moved quickly , such function can be cancelled by pressing button on display panel.

Automatic Malfunction Indication:

When machine displays any malfunction, code representing such malfunction appears on display panel for warning purpose.

Malfunction Messages Memory:

Opera Control System has feature of keeping occurred malfunctions in the machine in its memory.

Fuel filter Congestion Warning:

Notifies water in fuel filter to operator by view.

Manuel Mode Selection:

In case of any malfunction in control system of the machine, it is possible to switch to manual mode and continue operation by means of a button located near fuse box. Hydraulic pump flow rate is fixed and also engine rpm can be set between 900 rpm and maximum rpm manually.

Component Information and Main Setting Values:

Information regarding serial numbers of the components of the machine can be loaded on the control unit and may be recalled when required. It is also possible to read the required malfunction information on the display panel through the control unit during fault searching.

Program Loading and Modification:

There are computer connection ports on control unit of the machine. By means of such ports, programs of which parameters are either the same or different can be loaded on the machine.

AUXILIARY FEATURES

Automatic Powerboost:

When more power than normal working conditions is needed, electronic control system allows working at high performans through increasing system pressure.

Automatic Powershift:

If more power is needed during digging and travel , required power is obtained by mounting engine rpm and pump flow rate above setup value

Automatic Idling:

While levers are in the middle position, in case of no movements at levers, electronic control system decreases engine rpm to 1200 rpm and then decrease to idling in order to prevent redundant fuel consumption . Automotic Idling function can be activated also at any time determined by operator. When operator touches to lever , engine rpm and pump flow rate of previously selected mode is restored . This function can be canceled by operator if he desires. By this way desired power from engine can be obtained.

Condition Information:

Many parameters such as; battery voltage , engine load, pump pressures , cooling water temperature, and hydraulic oil temperature can be monitored

Maintenance Information:

There is warning system that informs operator about periodic maintenance time automotically. Also parameters related with machine maintenance can be monitored on control panel.

Operation Hours:

Detail working hours of machine , such as working hours, travel hours, attachment hours , breaking hours, are kept on the memory.

Anti-Theft System:

Anti-theft system is set up by defining private code for each operator.

Language Selection:

Selection of multi-language on the remote control panel.



EXCAVATOR

Since the very first phase of its design, the new generation GEN has been developed so that the user could control the machine with an extraordinary ease, in an environment of total comfort, feeling himself like in his own office.

That is why, GEN - the new generation of excavators Hidromek, for first time in its class, has been equipped with OPERA (Hidromek Operator Interface).

OPERA, the user interface especially developed for the GEN series Hidromek excavators integrates all the control devices on a aesthetically designed console ergonomically located for easy access and deal, a TFT color screen with high resolution, and the Electronic Control Unit.

With OPERA it is extraordinary easy to understand and manage functions such as:

- Engine RPM control
- Navigating and scrolling the menus
- Choose the most appropriate mode of working
- Control the lights and wipers
- Manage radio/MP3
- Stop-Start the engine to ensure maximum fuel economy during the waiting times.
- Control of the cameras – rear view and on the arm (optional)
- Observe the conditions information, such as hydraulic pressure, engine coolant and hydraulic oil temperature, turbo boost pressure, fuel pressure, atmosphere pressure and others.
- Error Codes
- Times of work - as a time of excavating, work with attachments (breakers etc), travel, etc.
- Time to the next maintenance

among others.



Electronic Visual Display



Instrument Panel

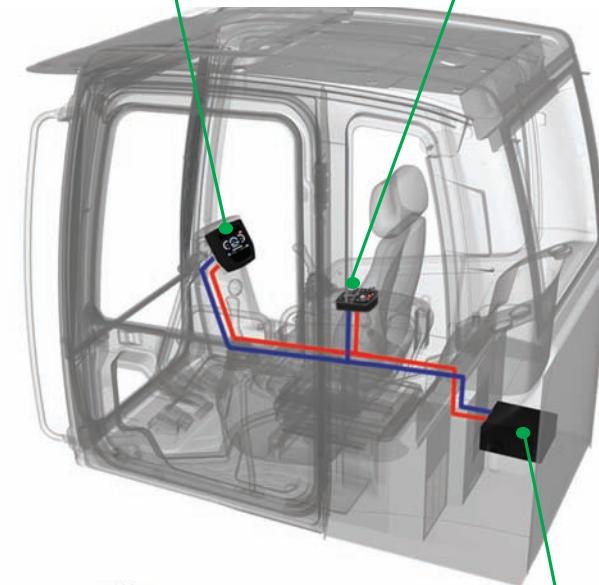

Electronic Control Unit





Features:

- Easy to control
- High efficiency
- Generation of required flow rate when needed (negative control)
- Continuous control of power generation depending on increasing load
- Maximum performance under all sorts of working conditions due to functional power modes
- Priority allowance in attachment movements
- Regeneration of flow rate in main control valve

Main Hydraulic Pump

Machine performance and pump life have been maximized by using two axial pistons and variable displacement hydraulic pumps from Kawasaki, a worldwide leading hydraulic pump manufacturer. It is possible to generate the necessary flow rate when required thanks to the negative control feature. Stalling of the engine is prevented by matching the power generated by diesel engine with the power required by the pump under increasing load. The best matching of the engine and pump flow rate is achieved with the power mode modulation depending on working conditions. By this way;

- High efficiency
- High quality
- Long and trouble-free operating life is achieved.

Main Control Valve

The main control valve ensures sensitive and vibration free operation in each combined movement. The operator is able to focus only on his work since the priority at the arm, boom and swing movements are provided automatically by the control valve, thus maximizing efficiency. The re-generative system prevents cavitations during boom, arm and bucket movements and increases both the life of the hydraulic system and speed of the machine.

Boom and arm load holding valves are supplied as standard in order to balance the interior leakage between spool and body so the potential leakage problem at the attachments is avoided.

Two-stage main relief valve provides possibility to increase power when required.

Straight travel valve exists within the main control valve. Due to the featured structure of the main valve block, it is possible to join the oil produced by both pumps within the valve group.

There is no need for an external pipe or hose for such operation.

An additional valve section is available for breaker or other optional attachments.

Swing Hydromotor and Gearbox

An axial piston type hydromotor with high torque is used together with a heavy duty type gearbox.

The hydromotor features shock absorbing valves specially designed to provide smooth and vibration free swing movement. The braking of the swing movement is provided by an oil type spring-driven park brake system.

Other features

The hydraulic accumulator which enables lowering of the attachments in case of emergency (i.e. diesel engine or main hydraulic pump failure) is fitted in the pilot line.

The advanced hydraulic system provides easy servicing and decreased spare part costs.

Hydraulic cylinders are designed with a cushioning system to provide a vibration and shock free operation.

The entire hydraulic system is fitted with high capacity filters so ensure absolute cleanliness.

Different types of breakers may be fitted by selecting desired flow rate and pressure on the control unit.



ENGINE

Brand, Model	: MITSUBISHI 4M50-TL
Type	: Water cooled diesel engine, 4 cycles, 4 cylinders, line-type, direct injection, turbocharger and intercooler
Emission Class	: Stage III-A (Tier 3)
Power	: 124 HP (92.5kW) at 2000 rpm SAE J1349
Maximum Torque	: 484 Nm at 1600 rpm
Displacement	: 4,900 cc
Bore x Stroke	: 114 mm x 120 mm
This new engine complies with the Emission Regulations U.S EPA Tier III and EU Stage III-A	

HYDRAULIC SYSTEM

Main Pump

Type	: 2 axial piston type pumps with double variable displacement and inclined plate
Max. Flow Rate	: 2 x 130 lt/min
Pilot Pump	: Gear type, 20 lt/min

Working Pressures

Cylinders	: 330 kgf/cm ²
Power Boost	: 360 kgf/cm ²
Travel	: 360 kgf/cm ²
Swing	: 260 kgf/cm ²
Pilot	: 40 kgf/cm ²

Cylinders

Boom	: 2 x 110 x 75 x 1,080 mm
Arm	: 1 x 115 x 80 x 1,225 mm
Bucket	: 1 x 100 x 70 x 910 mm

LUBRICATION

A central lubrication system is available in order to lubricate difficult-to-reach points such as boom and arm.

WARNING

Hidromek has the right to modify the specifications and design of the model indicated on this brochure without prior notice.

SWING SYSTEM

Motor	: Axial piston motor with integrated super shock absorbing valve, with fixed displacement and inclined plate
Reduction	: 2 stage planetary gear type v
Swing Brake	: Hydraulic, disc type with warning
Swing Speed	: 13 rpm

SUB-FRAME

Construction	: Lower structure "X" type, side frame pentagon box type
Shoe	: Triple grouser
No. of Shoes	: 2 x 46 units
No. of Lower Rollers	: 2 x 7 units
No. of Upper Rollers	: 2 x 1 units
Track Tensioning	: Hydraulic type with spring cushioning

CAB

- Improved operator's all round visibility
- Increased cabin internal space
- Use of six viscomount cabin mountings that dampen the vibrations
- High capacity A/C
- Cooled storage box
- Glass holder, book and object storage pockets
- Pool type floor mat
- Improved operator's comfort through versatile adjustable seat
- Ergonomically redesigned cabin through relocated switch board, and re-styled travel pedals and levers

FILLING CAPACITIES

Fuel Tank	: 270 L	Engine Oil	: 20.5 L
Hydraulic Tank	: 120 L	Swing Reduction Gear:	24L
Hydraulic System	: 216 L	Travel Reducer	: 2x2L
Engine Cooling Sys	: 24 L		

TRAVEL AND BRAKES

Travel	: Fully hydrostatic
Travel Motor	: Axial piston motor with 2 speed stages and inclined plate
Reduction	: Planetary gear system with 3 stages
Travel Speed	
High Speed	: 5.1 km/h
Low Speed	: 3.3 km/h
Max Traction	: 11,727 kgf
Gradeability	: 35° (70%)
Parking Brake	: Hydraulic, disc type with automatic warning
Ground Pressure	: 0.44 kgf/cm ²

ELECTRICAL SYSTEM

Voltage	: 24 V
Battery	: 2 x 12 V x 100 Ah
Alternator	: 24 V / 50 A
Starting Motor	: 24 V / 5.0 kW

Opera Control System

- | | |
|---|---|
| <ul style="list-style-type: none"> • Easy-to-use control panel and menus • Improved fuel economy and productivity • Maximum efficiency by selection of power and work modes • Overheat prevention and protection system without interrupting the work • Automatic powerboost switch-on and switch-off • Automatic electric power-off • Maintenance information and warning system • Error mode registry and warning system • Hidromek Smartlink (Optional) | <ul style="list-style-type: none"> • Automatic preheating • Auto-Idle and automatic deceleration system • Automatic powershift to improve performance • Selection of multi-language on control panel. • Real time monitoring of operational parameters such as pressure, temperature, engine load • Anti-theft system with personal code • Possibility to register 26 different operating hours • Rear-view, arm-view camera (Optional) |
|---|---|

WEIGHT

Standard machine operating weight : 14,350 kg

STANDARD BUCKET

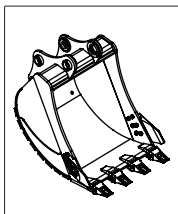

Width		983 mm	
Capacity		0.6 m ³	
Weight		490 kg	
ARM	2.0 m	4.6 m Mono Bom	A
	2.3 m		B
	2.6 m		B
	2.8 m		C

OPTIONAL BUCKET SELECTION DIAGRAM

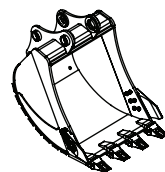

650 mm	780 mm	890 mm	1115 mm
0.35 m ³	0.45 m ³	0.52 m ³	0.75 m ³
350 kg	420 kg	440 kg	580 kg
A	A	A	C
A	A	A	C
A	A	A	D
A	A	A	D

- A- Material density less than 2.000 kg/m³
- B- Material density less than 1.800 kg/m³
- C- Material density less than 1.500 kg/m³
- D- Material density less than 1,200 kg/m³

BREAKOUT FORCES

4.6 m Mono Bom

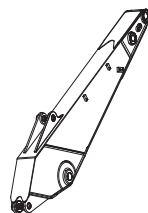















SAE	Arm length	2.0 m	2.3 m	* 2.6 m	2.8 m
	Bucket digging force (power boost)	8.800 (9.600) kgf	8.800 (9.600) kgf	8.800 (9.600) kgf	8.800 (9.600) kgf
	Arm breakout force (power boost)	7.500 (8.200) kgf	6.800 (7.400) kgf	6.200 (6.800) kgf	5.900 (6.400) kgf
ISO	Bucket digging force (power boost)	10.000 (10.900) kgf	10.000 (10.900) kgf	10.000 (10.900) kgf	10.000 (10.900) kgf
	Arm breakout force (power boost)	7.800 (8.500) kgf	7.000 (7.600) kgf	6.400 (7.000) kgf	6.000 (6.600) kgf



* Standard













WARNING

- Optional attachment and accessory standards offered with machines may differ according to countries.
- Please consult your authorized dealer to provide attachments and accessories.

HMK 140 LC Boom: 4.6m, Arm: 2.30m, Bucket: 0.60m³ (SAE),  Frontright  Side

A, m	Load Unit	1.5		3.0		4.5		6.0		7.5		Maximum Reach			
														A, m	
7.5	kg														
6.0	kg												*1900	*1900	5.55
4.5	kg							*2850	2150				*1800	*1800	6.50
3.0	kg			*5700	*5700	*4200	3350	3350	2050				*1850	1500	7.01
1.5	kg			*8850	5650	5150	3000	3200	1900				*2000	1350	7.17
0 (ground)	kg			*7350	5200	4900	2800	3100	1800				*2350	1400	6.99
-1.5	kg	*5000	*5000	*9800	5150	4800	2700	3000	1750				2700	1550	6.46
-3.0	kg	*8250	*8250	*9050	5250	4850	2750						3550	2050	5.47
-4.5	kg			*6100	5600								*4900	4100	3.64

HMK 140 LC Boom: 4.6m, Arm: 2.60m, Bucket: 0.60m³ (SAE),  Frontright  Side

A, m	Load Unit	1.5		3.0		4.5		6.0		7.5		Maximum Reach				
														A, m		
7.5	kg															
6.0	kg													*1550	*1550	5.95
4.5	kg							*2750	2150					*1450	*1450	6.85
3.0	kg					*3850	3400	3350	2050					*1500	1350	7.33
1.5	kg			*8200	5800	5100	3050	3200	1900					*1600	1250	7.48
0 (ground)	kg	*2200	*2200	*7650	5250	4900	2800	3050	1750					*1900	1250	7.32
-1.5	kg	*4500	*4500	*9250	5100	4750	2650	3000	1700					*2400	1400	6.81
-3.0	kg	*7300	*7300	*9400	5200	4750	2700							3200	1800	5.88
-4.5	kg			*6950	5450									*4700	3150	4.24

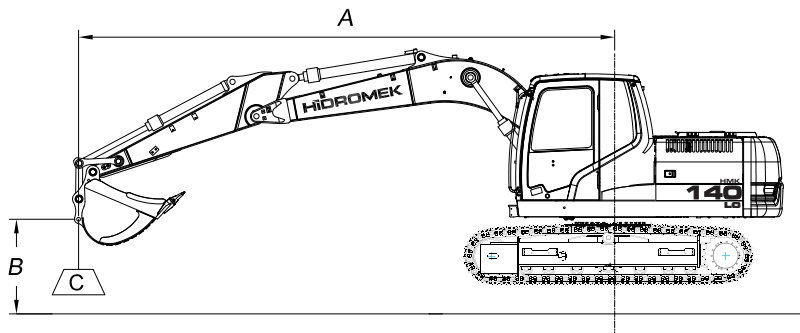

- A Load Radius
- B Load Point Height
- C Lifting Capacity

Notes

1. Lifting capacities are according to SAE J1097 and ISO 10567
2. Load point is on the bucket..
3. Lifting capacity cannot exceed 75% of tip over capacity or 87% of total hydraulic capacity.
4. Values marked with (*) are limited by hydraulic capacity.

DIMENSIONS

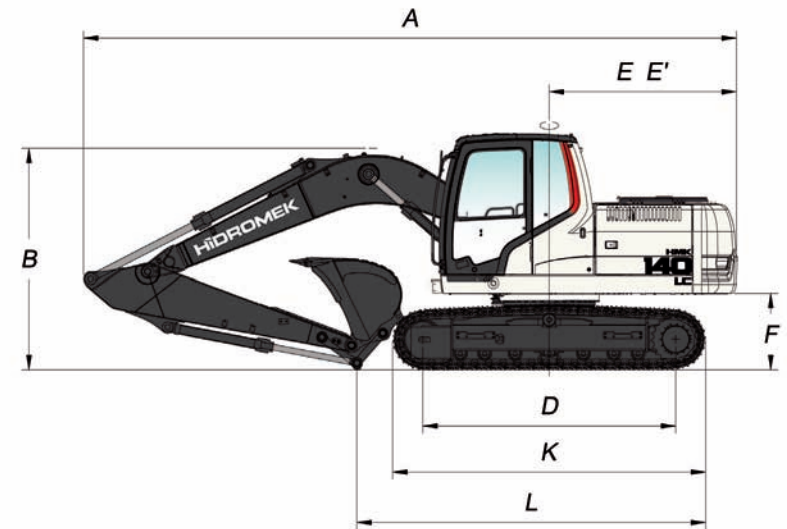
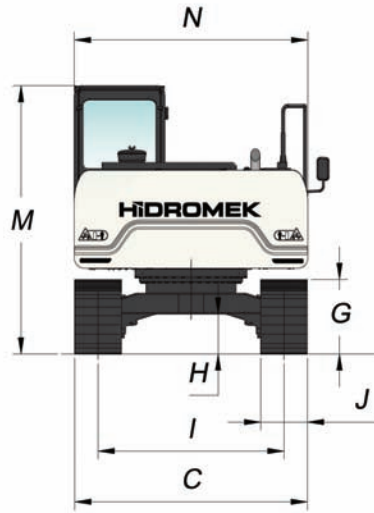
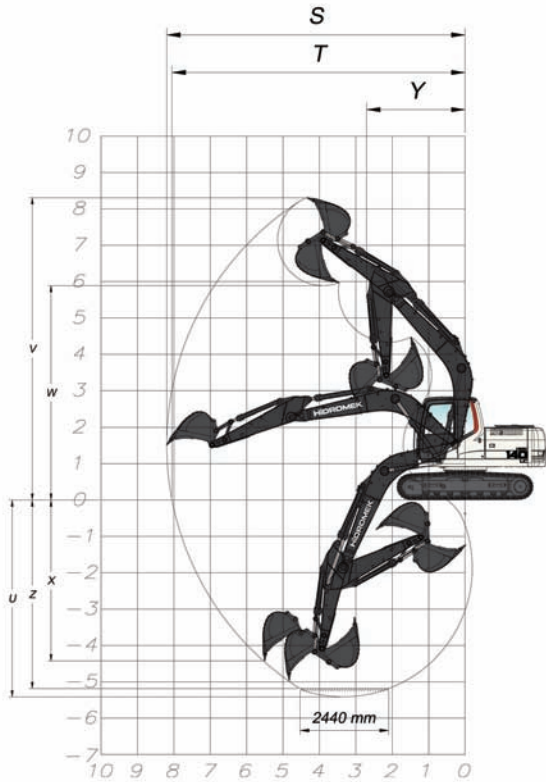

EXCAVATOR

GENERAL DIMENSIONS

	4.600 mm			
	2.000 mm	2.300 mm	*2.600 mm	2.800 mm
Boom Dimension	4.600 mm			
Arm Dimension	2.000 mm	2.300 mm	*2.600 mm	2.800 mm
A - Overall Length	7.840 mm	7.840 mm	7.840 mm	7.860 mm
B - Boom (Shipping) Height	2.640 mm	2.640 mm	2.640 mm	2.760 mm
C - Lower Frame Width	*2.490 / 2.590 mm			
D - Track Base Length	3.035 mm			
E - Counterweight Distance	2.246 mm			
E' - Counterweight Turning Radius	2.250 mm			
F - Upper Chasis to Ground Clearance	940 mm			
G - Crawler Height	800 mm			
H - Ground Clearance	430 mm			
I - Track Gauge	1.990 mm			
J - Shoe Width	*500 / 600 mm			
K - Lower Chasis Length (from shoe)	3.775 mm			
L - Shipping Length	4.470 mm			
M - Cab Height	2.880 mm			
N - Upper Frame Width	2.500 mm			

* Standard

WORKING DIMENSIONS

	4.600 mm			
	2.000 mm	2.300 mm	*2.600 mm	2.800 mm
S - Maximum Reach Distance	7.920 mm	8.200 mm	8.480 mm	8.660 mm
T - Maximum Reach at Ground Level	7.760 mm	8.050 mm	8.330 mm	8.520 mm
U - Maximum Digging Depth	5.090 mm	5.390 mm	5.690 mm	5.890 mm
V - Maximum Digging Height	8.170 mm	8.330 mm	8.520 mm	8.630 mm
W - Maximum Unloading Height	5.740 mm	5.920 mm	6.090 mm	6.210 mm
X - Maximum Vertical Wall Digging Depth	4.230 mm	4.390 mm	4.720 mm	4.900 mm
Y - Minimum Swing Radius	2.720 mm	2.720 mm	2.720 mm	2.710 mm
Z - Maximum Digging Depth (2440 mm level)	4.840 mm	5.160 mm	5.480 mm	5.690 mm

* Standard

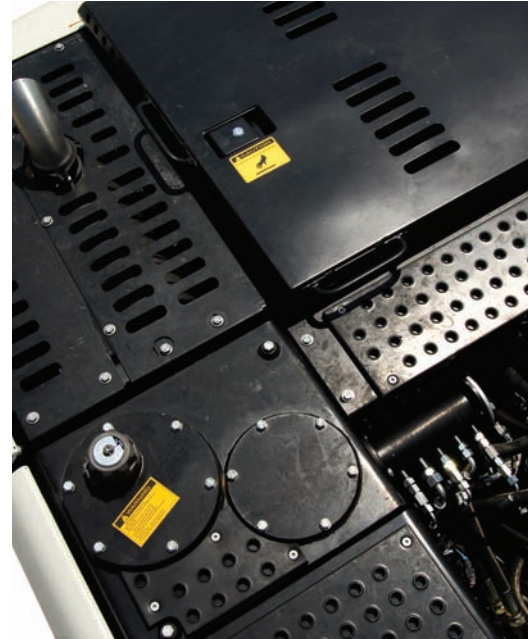



Special Equipment List

2.0 m, 2.3 m, 2.8 m arm
 600 mm track
 Various size buckets
 Automatic lubrication system
 Hydraulic breaker line
 Rotator line
 Boom safety valve
 Arm safety valve
 Overload warning system
 Beacon lamp
 Hydraulic breaker
 Hydraulic Quick Coupler
 Ripper
 Additional working lamp at the front
 Additional working lamp at the rear
 Windscreen protective netting
 Headlights
 Hidromek Smart Link
 Rear view camera
 Rotational moving hydraulic shear installation

Standard Equipment List

Radio/MP3
 Air conditioner
 Cab heating system
 Cab conforming to FOPS tests
 Computer connection port
 Oil and dust seal ring in chain pins
 Long life lubricating in rollers and direction wheel
 Fuel transfer pump
 Front air filter
 Double air filter
 Automatic idling
 Engine pre-heating facility
 Overheating, low engine pressure, air filter clogging indicators
 Battery charge warning system



HIDROMEK

www.hidromek.com

FACTORY - HEADQUARTERS

Ayaş yolu 25. km 1. Organize Sanayi Bölgesi Osmanlı Caddesi No: 1
06935 Sincan / ANKARA / TURKEY

Phone: (+90) 312 267 12 60 Fax: (+90) 312 267 21 12

www.hidromek.com email: export@hidromek.com.tr

Warning

HIDROMEK has the right to modify the specifications and design of the model indicated on this brochure without prior notice