

# HYDRA RAM<sup>®</sup>

DEMOLITION & RECYCLING EQUIPMENT



**HCB SERIES**



**HARDOX**  
IN MY BODY

**3 MODELS CRUSHING BUCKETS FROM 1500 UP TO 3500 KGS  
FOR EXCAVATORS FROM 12 ~ 45 TONS**



# HYDRA RAM®

DEMOLITION & RECYCLING EQUIPMENT

## HCB SERIES

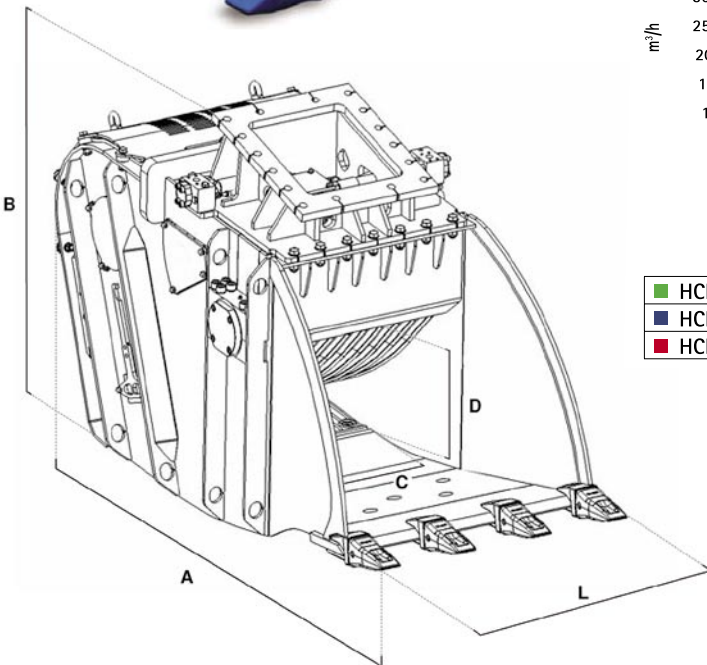

Productivity according to material/granulation

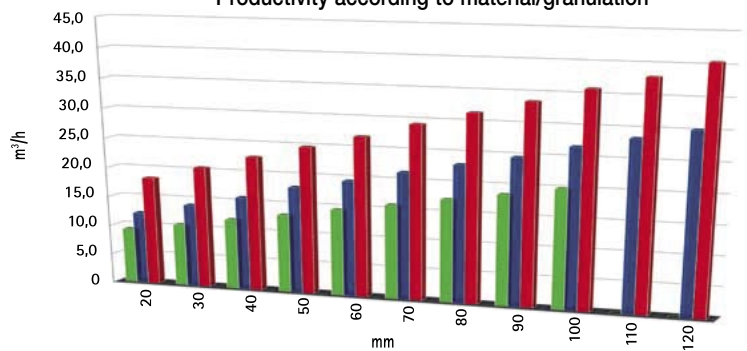

	20	30	40	50	60	70	80	90	100	110	120
■ HCB-15	9,3	10,5	11,9	13,2	14,6	15,9	17,3	18,6	20,0		
■ HCB-25	12,2	14,0	15,8	18,0	19,5	21,4	23,1	24,7	26,8	28,5	30,2
■ HCB-35	18,3	20,5	22,7	24,8	26,9	29,3	31,5	33,6	35,9	38,0	40,5

	(1)	*	A	B	C	D	L	Cap. SAE			Drain line	Granulate setting
	t.	kg.	mm.	mm.	mm.	mm.	mm.	m³	l/min.	bar		mm.
HCB-15	12 : 20	1500	2050	1180	600	450	830	0,5	150	200	✓	20 / 100
HCB-25	18 : 25	2500	2450	1290	750	550	970	0,6	180	220	✓	20 / 120
HCB-35	25 : 45	3500	2750	1410	900	650	1170	0,9	180	220	✓	20 / 120

(\*) The above mentioned weight is without connection plate  
 (1) Recommended excavator / attachment combination

(DEALER)



**HYDRA RAM®**  
 DEMOLITION & RECYCLING EQUIPMENT

HYDRARAM b.v.  
 Meander 7  
 NL 9231DB SURHUISTERVEEN  
 The Netherlands

tel. +31 512-365981  
 fax. +31 512-365761  
 www.hydraram.com  
 info@hydraram.com