

## TECHNISCHES DATENBLATT ROCKWHEEL G55

Unsere hydraulische Anbaufräse Rockwheel G 55 wird je nach Kundenwunsch mit Abbruch oder Lösetrommeln ausgestattet.

### TECHNISCHE DATEN G55

Hydraulikleistung	- 220 kW	- 295,0 hp
Maximale Ölmenge	- 680.0 lpm	- 149.5 UK gpm
Optimale Ölmenge	- 540.0 lpm	- 142.0 UK gpm
Maximaler Druck	- 400 bar	- 5,801 psi
Drehmoment Fräse	- 47,028 Nm @ 350 bar	- 34,686 lbf ft @ 5,076 psi
Drehmoment Meissel	- 129.5 kN @ 350 bar	- 29,113 lbf @ 5,076 psi
Trommel Geschwindigkeit	- 53.0 rpm @ 360 lpm	- 50.0 rpm @ 79.2 UK gpm
Meissel Geschwindigkeit	- 2.0 m/s @ 360 lpm	- 6.56 ft/s @ 79.2 UK gpm
Betriebsgewicht	- 2,478.0 kg	- 5,463 lb
Baggergröße	- 50.0 – 65.0 t	- 50.0 – 65.0 tonne
Anzahl Meissel	- 54 (38 / 30 mm Schaft)	- 54 (1.5" / 1.18" Stepped Shank)

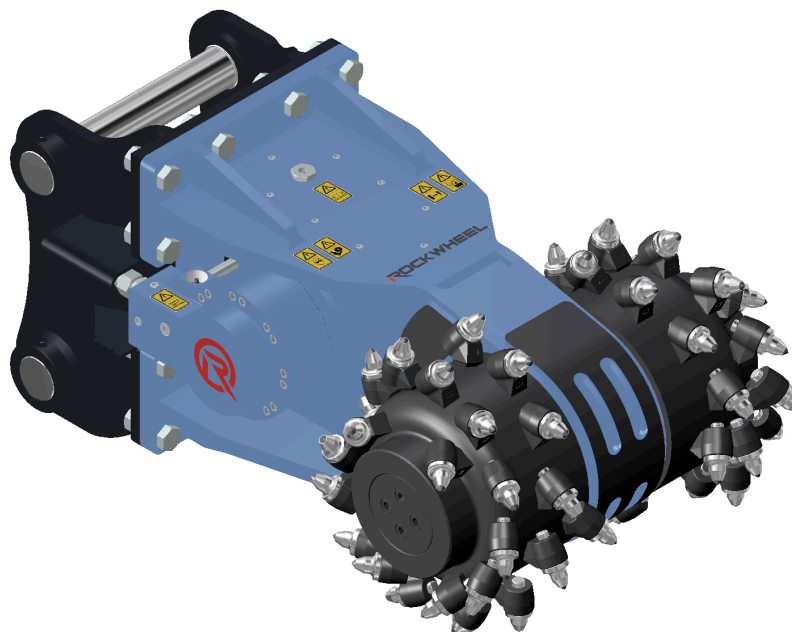

**ROKLA**

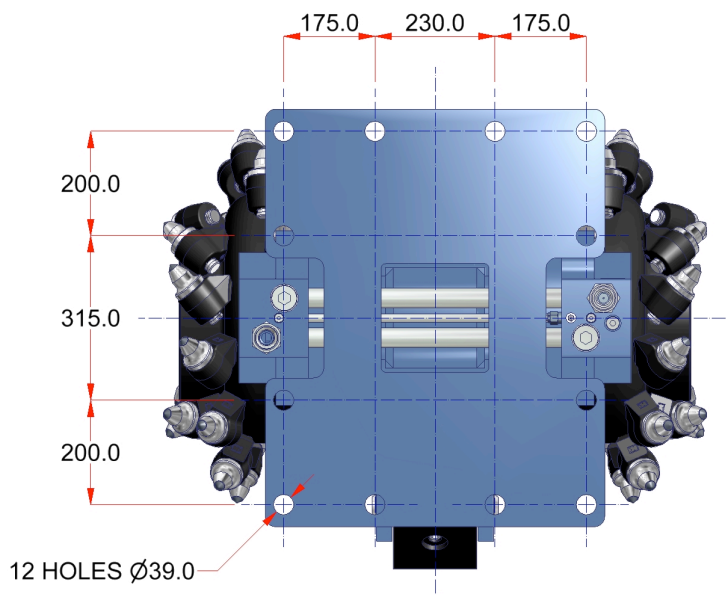
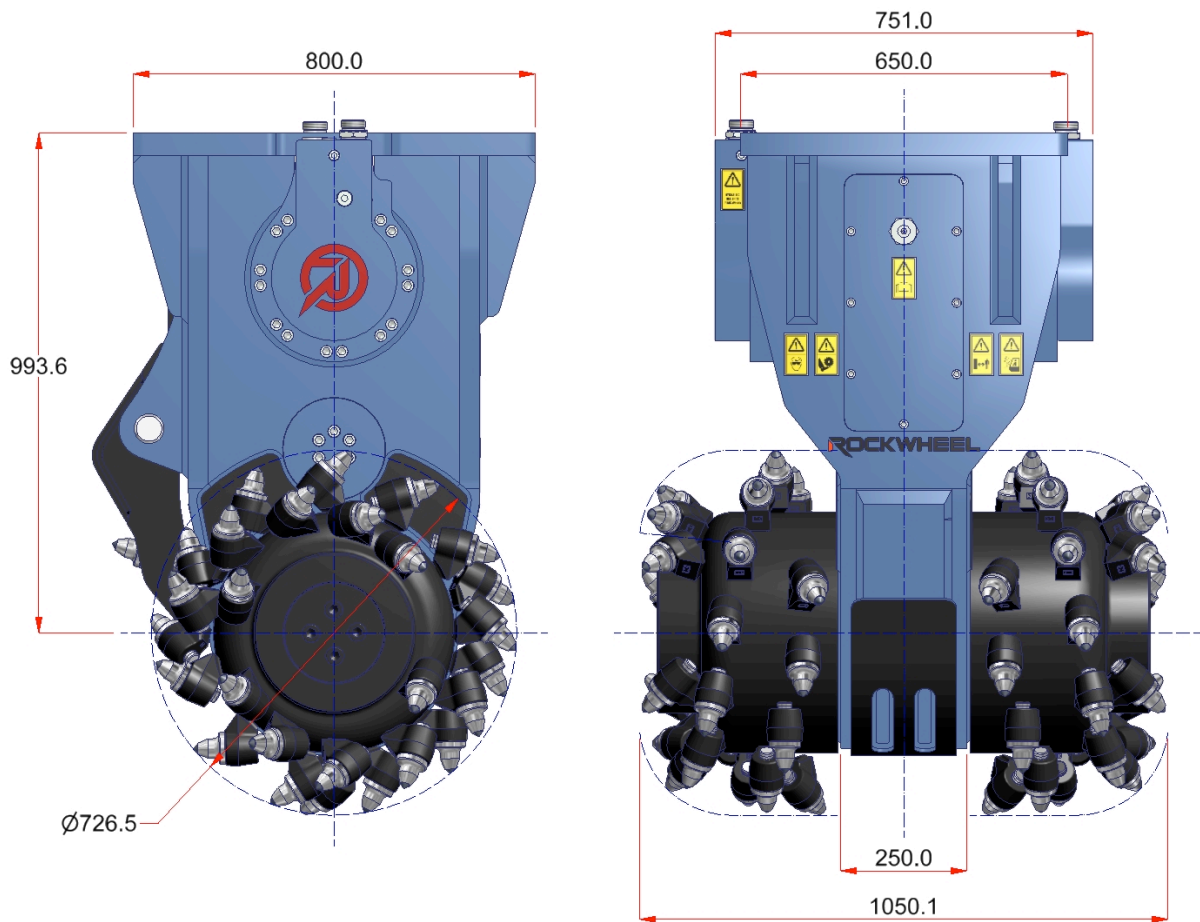

## ROKLA

ROKLA GmbH - Hauptstr. 197 - 74595 Langenburg  
 T +49 (0) 7905 9419 -602 F +49 (0) 7905 9419 -609  
 E [info@rockwheel.com](mailto:info@rockwheel.com) W [www.rockwheel.com](http://www.rockwheel.com)