

# MODEL RANGE

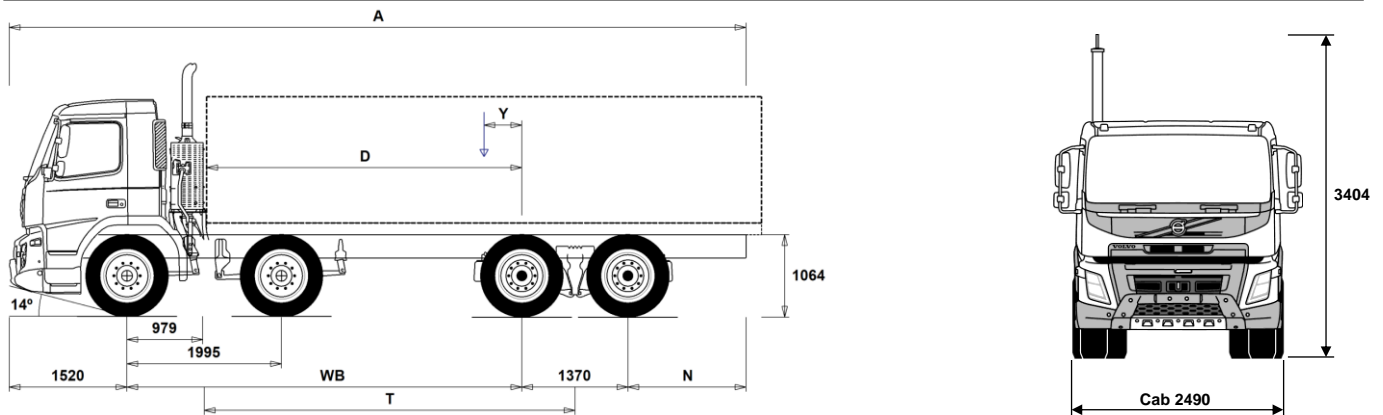

Volvo Trucks. Driving Progress

FMX13 8x4 Rigid - Rear Air Suspension - N3 Cranked front axles for on road work FM



## Chassis Dimensions [mm]

WB Wheelbase	5100	5600	6000	6400
A Overall Chassis Length	10815	11565	12215	11915
D Center of rear axle to front of body	4071	4571	4971	5371
N Rear Overhang (Min.)	1225	1225	1225	1225
N Rear Overhang (Max.)	2825	3075	3325	2625
T Theoretical Wheelbase	4788	5288	5688	6088
Y Center of Gravity for Payload (Min.)	630	784	908	1017
Y Center of Gravity for Payload (Max.)	1273	1497	1676	1839

## Chassis Weights [kg]

Front Axles	6870	6810	6770	6785
Rear Bogie	2810	2930	3000	2995
Kerb Weight	9680	9740	9770	9780
Payload (including body, driver, fuel, etc.)	22320	22260	22230	22220

## Turning Diameter [mm]

Turning Circle Diameter Kerb to Kerb	20600	22200	23500	24800
Turning Circle Diameter Wall to Wall	22100	23700	25000	26200

## Plated Weights [kg]

	Plated	Design
Gross Vehicle Weight	32000	37000
Gross Combination Weight	44000	44000
Front Axles	16000	16000
Rear Bogie	19000	21000

## Important Notes

### Chassis Dimensions

Cab Height: +167 mm for CAB-HSLP, +167 mm for CAB-SLP, +224 mm for CAB-XHSL.

Front Axle to Back of Cab: +506 mm for CAB-HSLP and CAB-SLP and CAB-XHSL.

D-measure includes a front clearance of 50 mm and for rigid trucks also a subframe of 100 mm.

Height can vary  $\pm 20$  mm for leaf and  $\pm 10$  mm for air suspension.

All dimensions are for unladen chassis and any tag axles down. Chassis height used: CHH-HIGH.

Rear overhang used for vehicle weight calculation is the maximum rear overhang (N Max.) for selected wheelbase.

Height change when chassis height CHH-MED,FRAME300: 0 mm.

Weight and dimensions are based upon the following tyres:

Front Axle Tyres: 315/80R22.5  
Drive Axle Tyres: 315/80R22.5

**Chassis weight includes oil, water, AdBlue, 0 litres fuel and without driver. Kerb weight can vary  $\pm 3\%$ .**

Turning diameters are theoretically calculated.

Legal weights can differ from country to country.

For more detailed weight information, including optional equipment weights, ask your Volvo sales contact to enter your specification into the Volvo Weight Information system (WIS).

Do NOT use this drawing for bodybuilding. Refer to Volvo Bodybuilder Instructions and chassis assembly drawing FM84FR3HAX.

# MODEL RANGE

## FMX13 8x4 Rigid - Rear Air Suspension - N3 Cranked front axles for on road work FM

### TRUCK USE

- PTO-HT16** High torque power take-off up to 1600Nm
- PTO-HT20** High torque power take-off up to 2000Nm
- RC-ROUGH** Operating class on/off road
- RC-SMOOT** Operating class highway
- TIPP-PRE** Tipper vehicle preparation
- UNIFORM** Basic platform vehicle

### CORE COMPONENTS

- **CHH-HIGH** Chassis height standard - For a specific loading height always check the unique BEP chassis drawing
- CHH-MED** Chassis height medium - For a specific loading height always check the unique BEP chassis drawing
- **RADD-GR** Rear air suspension, 2 axles - 2 driven
- **FMX-DAY** Day cab - with steel safety cage design  
Designed and built to Swedish impact and ECE R29 regulations
- FMX-HSLP** Globetrotter cab - with steel safety cage design  
Designed and built to Swedish impact and ECE R29 regulations
- FMX-SLP** Sleeper cab - with steel safety cage design  
Designed and built to Swedish impact and ECE R29 regulations
- **EU6SCR** Emission level - Euro 6
- **D13K420** D13K420 12.8l engine developing 420hp at 14-1800rpm.  
Peak torque 2100Nm at 860 -1400rpm.
- D13K460** D13K460 12.8l engine developing 460hp at 14-1800rpm.  
Peak torque 2300Nm at 900-1400rpm.
- D13K500** D13K500 12.8l engine developing 500hp at 14-1800rpm.  
Peak torque 2500Nm at 1000-1400rpm.
- D13K540** D13K540 12.8l engine developing 540hp at 14-1800rpm.  
Peak torque 2600Nm at 1000-1450rpm.
- EBR-EPG** Exhaust brake controlled by steering column switch
- EBR-EPGC** Exhaust pressure governor for I shift gearbox
- EBR-VEB+** Volvo engine brake + and exhaust pressure governor, enhanced performance from additional exhaust rocker control. Retardation 375kW
- **AT2612F** AT2612F 12-speed "I-shift" automated mechanical gearbox suitable for gross train weights up to 60tonne only refer to sales engineering when used in conjunction with a PTO
- ATO2612F** ATO2612F 12-speed "I-shift" overdrive automated mechanical gearbox suitable for gross train weights up to 60tonne refer to sales engineering when used in conjunction with a PTO
- PT2606** Powertronic automatic 6-speed gearbox, max. engine torque 2600 Nm, max. permitted GCW 130000 kg
- SPO2812** SPO2812 - 12 speed I-shift Dual Clutch automated mechanical gearbox GCW 60tonne
- TAAXLIFT** Rear axle lift for double drive bogie  
CONTACT YOUR SALES ENGINEER to check lift capability
- RTH2610F** RTH2610F hub reduction tandem 26tonne drive axles, GCW 100 tonnes with differential and cross locks\*  
\* Cross locks replaced by a dog clutch if tandem axle lift is specified
- **RTS2370A** RTS2370A single reduction tandem 23tonne drive axles with differential and cross locks\* - design GCW 70tonnes.  
\* Cross locks replaced by a dog clutch if tandem axle lift is specified

### PACKAGES

- DRIVEFM** Driving package
- DRIVEFM+** Driving plus package
- BEDFM** One bed resting package
- AUDHIG** High Power Audio system: RDS radio with CD player - also playing MP3/WMA files from CD -, with integrated bluetooth phone and USB/Line inputs. FM/AM antenna, speakers in

- Standard Equipment
- Optional Equipment

For more detailed information about cab and powertrain equipment, please refer to separate specification sheets.

For all possible options and combinations of options please consult your Volvo sales contact who can create a specification to match your requirements using the Volvo Sales Support system (VSS).

The factory reserves the right to modify design and change equipment without previous notification. The specification can vary from country to country.

- MEDIA** dashboard, doors, and sleeping compartment.  
AM/FM Bluetooth radio without CD player.  
USB and Aux line inputs.  
Speakers in dashboard, doors, and sleeping compartment.  
7" touch screen with personal apps.
- MEDIADF** AM/FM Bluetooth radio without CD player.  
USB and Aux line inputs.  
Speakers in dashboard, doors, and sleeping compartment.  
7" touch screen with personal and professional apps.  
Dynafleet vehicle on-board data display with office internet support.
- MEDIANAV** AM/FM Bluetooth radio without CD player.  
USB and Aux line inputs.  
Speakers in dashboard, doors, and sleeping compartment.  
7" touch screen with personal and professional apps.  
Truck based satellite navigation (live updates not included)
- MEDIANDF** AM/FM Bluetooth radio without CD player.  
USB and Aux line inputs.  
Speakers in dashboard, doors, and sleeping compartment.  
7" touch screen with personal and professional apps.  
Truck based satellite navigation (live updates not included)  
Dynafleet vehicle on-board data display with office internet support.
- VISIX15** Visibility package
- RCHAPAC1** Chassis Package Rigid
- CHASSIS**
  - FST-AIR** Front suspension type - air
  - FST-PAR** Front suspension type - 2 leaf parabolic springs
  - **FST-PAR3** Front suspension type - 3 leaf parabolic springs
  - **FAL16.0** Front axles design capacity 16 tonnes - 2 x 8.0 tonne front axles
  - FAL18.0** Front axles design capacity 18 tonnes - 2 x 9 tonne front axles - check tyre load index
  - FAL20.0** Front axles design capacity 20 tonnes - 2 x 10.0 tonne front axles - UK weight 17tonnes in use - check tyre load index
  - **FSM-LUB** Lubricated rear shackles on front suspension pins and bushings
  - FSTAB** Front anti-roll bar
  - **FSTAB2** Front anti-roll bar medium stiffness
  - FSTAB3** Front stiff anti-roll bar
  - **RAL21** Rear bogie design capacity 21 tonnes
  - RAL23** Rear bogie design capacity 23 tonnes
  - RAL26** Rear bogie design capacity 26 tonnes
  - **RSTAB1** Rear anti-roll bar
  - RSTAB3** Rear stiff anti-roll bar
  - RALIM105** Rear axle load limiter, 10.5 tonnes
  - **RALIM115** Rear axle load limiter, 11.5 tonnes
  - RALIM13** Rear axle load limiter, 13 tonnes
  - RALIM95** Rear axle load limiter, 9.5 tonnes
  - ACTST-TO** Volvo Dynamic Steering (VDS) with with extra electronic pump and torque overlay
  - ASFE-BAS** Active steering feature - Basic - Volvo Dynamic Steering only
  - ASFE-PS** Active steering feature - Volvo Dynamic Steering with personal settings
  - **PSS-DUAL** Dual power steering system
  - **PSP-VAR** Power steering pump with variable displacement
  - **EBS-MED** EBS medium package including "hill" hold function
  - AUXPARK** Additional spring parking brakes
  - **ABS** Anti lock brakes
  - **FBREG-E** Front regulating brake valve, EBS
  - **SUSPL-EC** Remote electronic control on wander-lead for air suspension levelling
  - **FRAME300** Frame rail section external height 300 mm

# MODEL RANGE

## FMX13 8x4 Rigid - Rear Air Suspension - N3 Cranked front axles for on road work FM

- **FST8080** Frame thickness - web and flange 8.0mm
  - **FIL-EEEB** Inner liner from end of engine to end of bogie
  - **FIL-EEEF** Inner liner from end of engine to end of frame
  - **FIL-FBEB** Inner liner over rear bogie
  - **FIL-FBEF** Inner liner from front of bogie to end of frame
  - **FIL-TXEB** Inner liner from gearbox member to end of bogie
  - **FIL-TXEF** Inner liner from gearbox member to end of frame
  - **BBOX-L** Battery box located on left hand side
  - **2BAT210B** 2 x 210 Ah capacity Gel batteries
  - **2BATT170** 2 x 170 Ah capacity batteries
  - **2BATT225** 2 x 225 Ah capacity batteries
  - **BATTAMP** Battery voltage and ampere gauge
  - **BATTIND** Battery charge indication
  - **ADR2** ADR package for transportation of dangerous goods on road (Note does NOT include safe loading pass package if required this is quoted separately)
  - **MSWI-A** Main switch - ADR switch circuit shut down
  - **MSWI-C** Main switch - Chassis mounted toggle switch by battery box
  - **MSWI-R** Main switch - Key fob operated remote controlled
  - **R315A56** Right aluminium 560 mm D-shaped fuel tank, 315 litres volume  
Min volume 255l  
Max volume 810l
  - **UL-FUEL** Without left fuel tank  
Min volume 160l  
Max volume 450l
  - **ADTP-L** AdBlue tank on left hand side
  - **ADTP-LF** AdBlue tank on left hand side at the front
  - **ADTP-R** AdBlue tank on right hand side
  - **ADB032** AdBlue tank usable volume 32 litres
  - **ADB048** AdBlue tank usable volume 48 litres
  - **ADB064** AdBlue tank usable volume 64 litres
  - **ADTC-BF** AdBlue tank cover with satin alloy look decorative cover
  - **FCAP-L** Locking fuel filler cap
  - **FUFF-AS** Fuel filling anti-spillage device
  - **FUFF-ATS** Fuel filling anti-theft and anti-spillage devices
  - **ESH-LEFT** Horizontal silencer, left exhaust outlet
  - **ESH-REAR** Horizontal silencer, rear exhaust outlet
  - **ESH-RIGH** Horizontal silencer, right exhaust outlet
  - **ESH-VERT** Horizontal silencer, vertical exhaust outlet
  - **ESHVVERT** Horizontal chassis mounted diesel particulate filter and vertical SCR silencer behind cab
  - **EXST-SSP** Stainless steel exhaust stack - NOT polished
  - **EXST-ST** Steel exhaust stack
  - **WHC-FIX2** Two fixed wheel chocks
  - **WHC-FOL2** Two foldable wheel chocks
  - **WHCP-F** Wheel chock(s) stored in the front part of the vehicle
  - **WHCP-R** Wheel chock(s) stored in the rear part of the vehicle
  - **WHCP-T** Transport mounted wheel chock(s) stored in cab outer luggage locker
  - **TB-L80** Toolbox 800 mm, left side
  - **TB-R80** Toolbox 800 mm, right side
  - **SUP-BAS** EC approved chassis side guards
  - **SUP-LOW** EC approved low chassis side guards
  - **CHAIN-S** Snow chains
  - **HOOK-SC** Snow chain hooks
  - **TOWF-HD1** One heavy duty front towing device
  - **TOWMBRH** Towing member, high mounted in centre of frame, D = 190
  - **TOWMBRL1** Towing member, low mounted under the frame
  - **TOWMBRM** Towing member, medium mounted in line with frame lower flange
  - **RFEC-S** Rear frame end, straight cut for regular platform applications
  - **RFEC-U** Rear frame end, upper cut for tipper applications.
  - **C-RI4040** Towing coupling, Ringfeder 4040 G-150
  - **C-RI5055** Towing coupling, Ringfeder 5055 G-150
  - **C-RO400G** Towing coupling, Rockinger 400 G-150 for 40mm eyes
  - **C-RO50** Rockinger RO 50 50mm for centre axle trailer
  - **TOWR-ONE** Towing hitch attached to rear crossmember
  - **TREL-PK** Trailer electrical preparation kit - chassis/cab wiring
  - **TREL14** Single 14 pole electrical trailer connector
  - **TREL15** Single 15 pole electrical trailer connector - ADR certified
  - **TREL7** 7 pole - 24N trailer electrical suzie
  - **TREL7-7** 24N and 24S trailer electrical suzies
  - **TBC-DUO** Duomatic type air line connectors
  - **TBC-EC** Palm coupling type air line connectors
  - **TRBR-HCF** Full pressure hand controlled trailer brake
  - **TRBR-STA** Stationary trailer brake control
  - **TRB-STRE** Stretch Brake - Automatic low speed trailer brake activation to avoid jack-knifing and improve steerability
  - **RUP-FOSL** Folding & sliding EC approved aluminium rear underrun
  - **FFEND-B** Standard mounted mud wings on second front axle
  - **FFEND-T** Transport mounted mud wings on second front axle
  - **RFEND-B** Three piece EC approved rear mud wings and spray flaps
  - **RFEND-T** Rear mud wings, transport mounted
  - **RFH-BAS** Basic rear wing height
  - **RFH-HIG** High rear wing height - higher wing tops
  - **RFH-LOW** Lower rear wing height - shallower wing tops
  - **ATANK-AL** Aluminium air tanks
  - **ATANK-ST** Steel air tanks
  - **TL-LED** LED Tail lights
  - **BLIGHT-E** Emergency brake light
- ### WHEELS & TYRES
- **RT-AL** Alcoa brushed aluminium rims with standard holes for long stud fixing on all axles
  - **RT-ALDP** Alcoa Dura-Bright EVO aluminium rims with standard holes long stud fixing on all axles, requires cleaning with a ph neutral solution - washing up liquid.
  - **RT-ALDPD** Alcoa Dura-Bright EVO aluminium rims with countersunk holes for short stud fixing on all axles, requires cleaning with a ph neutral solution - washing up liquid.
  - **RT-ALDU** Alcoa brushed aluminium rims with countersunk holes for short stud fixing on all axles
  - **RT-SPOKE** Spoke rims on all axles
  - **RT-STEEL** Steel rims on all axles
  - **WCAP** Aerodynamic hub caps
  - **SPWT-D** Spare wheel & tyre with rear tyre pattern
  - **SPWT-F** Spare wheel & tyre with front tyre pattern
  - **SWCP-LF** Spare wheel carrier on left side of chassis ahead of rear axle
  - **SWCP-T** Spare wheel supplied temporarily strapped to chassis
  - **SWCP-TP** Temporary spare wheel carrier on top of chassis frame
  - **JACK-12T** 12 tonne bottle jack
  - **JACK-15T** 15 tonne bottle jack
  - **JACK-20T** 20 tonne bottle jack
  - **TOOL-BAS** Basic Toolkit
  - **TOOLKIT** Complete tool kit
  - **INFLAHOS** Tyre inflation hose
  - **GAUGE-TP** Tyre pressure gauge
  - **OBDEP-C** Euro 6 Step C emission level
  - **OBDEP-D** Euro 6 Step D emission level
- ### DRIVELINE EQUIPMENT
- **ASO-C** Crawler gear -  
Ratio direct top gearbox 19:1  
Ratio Overdrive gearbox 17:1
- Standard Equipment      □ Optional Equipment

For more detailed information about cab and powertrain equipment, please refer to separate specification sheets.

For all possible options and combinations of options please consult your Volvo sales contact who can create a specification to match your requirements using the Volvo Sales Support system (VSS).

The factory reserves the right to modify design and change equipment without previous notification. The specification can vary from country to country.

# MODEL RANGE

## FMX13 8x4 Rigid - Rear Air Suspension - N3 Cranked front axles for on road work FM

<input type="checkbox"/> <b>ASO-ULC</b>	Ultra low crawler and crawler gear - Ratios direct top gearbox 32:1 and 19:1 Ratios Overdrive box 32:1 and 17:1	<input type="checkbox"/> <b>HPE-V45</b>	Parker VP1-45, variable displacement, single flow, engine mounted hydraulic pump
<input type="checkbox"/> <b>TRAP-HD</b>	Reinforced gearbox application	<input type="checkbox"/> <b>HPE-V75</b>	Parker VP1-75, variable displacement, single flow, engine mounted hydraulic pump
<input type="checkbox"/> <b>TP-CON</b>	Construction Package	<input type="checkbox"/> <b>PTPT-D</b>	Powertronic PTO, 1 front/upper DIN connection for plug-in pump (max. 850 Nm)
<input type="checkbox"/> <b>TP-DIST</b>	Distribution Package	<input type="checkbox"/> <b>PTPT-F</b>	Powertronic PTO, 1 front/upper rear facing SAE flange conn. for prop shaft (max.850 Nm)
<input type="checkbox"/> <b>TP-HD</b>	I-shift software - Heavy duty for high GCW	<input type="checkbox"/> <b>PTR-D</b>	Gearbox PTO for plug-in pump, 0.71xeng speed
<input type="checkbox"/> <b>TP-LONG</b>	Special conditions apply consult Sales Engineering Long Haul Package	<input type="checkbox"/> <b>PTR-DH</b>	Gearbox driven high speed PTO for one plug-in hydraulic pump
<input type="checkbox"/> <b>AMSO-AUT</b>	Enhanced I-shift software with manual shift available in auto mode and kickdown facility on accelerator pedal	<input type="checkbox"/> <b>PTR-DM</b>	Gearbox driven medium speed PTO for one plug-in hydraulic pump
<input type="checkbox"/> <b>AVO-ENH</b>	Enhanced software for off road driveability and starting	<input type="checkbox"/> <b>PTR-F</b>	Gearbox driven PTO with rear flange connection
<input type="checkbox"/> <b>APF-ENH</b>	I-shift enhanced PTO functions	<input type="checkbox"/> <b>PTRD-D</b>	Gearbox driven HIGH SPEED PTO for two plug-in hydraulic pumps
<input type="checkbox"/> <b>CD43-O</b>	Dual plate clutch, plate diameter 430 mm	<input type="checkbox"/> <b>PTRD-F</b>	PTO with 1 DIN + 1 flange connection rear, manual gearbox
<input checked="" type="checkbox"/> <b>CS43B-O</b>	Single plate 430mm (17") clutch	<input type="checkbox"/> <b>HPG-F101</b>	Parker F1-101 gearbox mounted, fixed displacement, single flow, hydraulic pump
<input type="checkbox"/> <b>RET-TH</b>	Gearbox mounted retarder	<input type="checkbox"/> <b>HPG-F41</b>	Parker F1-41 gearbox mounted, fixed displacement, single flow, hydraulic pump
<input type="checkbox"/> <b>RET-TPT</b>	Hydraulic Retarder for Powertronic gearbox	<input type="checkbox"/> <b>HPG-F51</b>	Parker F1-51 gearbox mounted, fixed displacement, single flow, hydraulic pump
<input type="checkbox"/> <b>TC-HWO</b>	Automatic gearbox oil cooler - water to oil	<input type="checkbox"/> <b>HPG-F61</b>	Parker F1-61 gearbox mounted, fixed displacement, single flow, hydraulic pump
<input type="checkbox"/> <b>TC-MAOH2</b>	Extra high performance transmission oil cooler - air to oil with front mounted radiator	<input type="checkbox"/> <b>HPG-F81</b>	Parker F1-81 gearbox mounted, fixed displacement, single flow, hydraulic pump
<input type="checkbox"/> <b>TC-MWO</b>	Basic transmission oil cooler - water to oil	<input type="checkbox"/> <b>EIDLESD</b>	Engine idle shut down
<input type="checkbox"/> <b>TC-MWOH2</b>	High performance transmission oil cooler - water to oil	<input type="checkbox"/> <b>STWPOS-L</b>	LEFT HAND DRIVE
<input type="checkbox"/> <b>2COM1100</b>	Two cylinder, air compressor, 1100 litres per minute	<input checked="" type="checkbox"/> <b>STWPOS-R</b>	RIGHT HAND DRIVE
<input checked="" type="checkbox"/> <b>2COMP900</b>	Two cylinder, air compressor, 900 litres per minute	<input type="checkbox"/> <b>STWM-LE</b>	Leather steering wheel
<input type="checkbox"/> <b>CLU-AIRC</b>	Clutchable air compressor	<input type="checkbox"/> <b>STGW-AD2</b>	Adjustable steering wheel with neck tilt
<input checked="" type="checkbox"/> <b>AIRIN-HI</b>	Roof mounted air intake behind cab on left hand side	<input checked="" type="checkbox"/> <b>STGW-ADJ</b>	Adjustable steering wheel
<input type="checkbox"/> <b>AIRIN-LO</b>	Low level air intake behind cab on left hand side	<input checked="" type="checkbox"/> <b>AIRBAG</b>	SRS Driver's air bag
<input type="checkbox"/> <b>ACL1ST-S</b>	Two stage air filter	<input checked="" type="checkbox"/> <b>DRC-AMII</b>	DPF Regeneration control switch - for manual and switching off regeneration
<input checked="" type="checkbox"/> <b>24AL110B</b>	110 amp alternator	<input type="checkbox"/> <b>1DAYDIG</b>	Continental VDO DTCO 3.0 digital tachograph This tachograph can ONLY offer remote download if the option of Dynafleet or an FMS gateway has been specified with this order.
<input type="checkbox"/> <b>24AL120B</b>	120 amp alternator	<input checked="" type="checkbox"/> <b>1DAYDIG2</b>	Continental VDO DTCO 4.0 smart tachograph This tachograph can ONLY offer remote download if the option of Dynafleet or an FMS gateway has been specified with this order.
<input type="checkbox"/> <b>24AL150B</b>	150 amp alternator	<input type="checkbox"/> <b>1DAYDIGP</b>	Continental VDO DTCO 3.0 digital tachograph For vehicles with long lead time - this includes prep kit for the retrofit of DTCO 4.0 tachograph. For updating to new legal demand for trick registration from 15th June 2019. This tachograph can ONLY offer remote download if the option of Dynafleet or an FMS gateway has been specified with this order.
<input checked="" type="checkbox"/> <b>CCV-C</b>	Closed crankcase engine ventilation	<input type="checkbox"/> <b>ARSL</b>	Additional road speed limit - switch in dashboard
<input type="checkbox"/> <b>CCV-O</b>	Open crankcase engine breather	<input type="checkbox"/> <b>CRUIS-E</b>	Eco cruise control (with eco-roll and I-cruise, controls in steering wheel)
<input type="checkbox"/> <b>CCV-OX</b>	Closed crankcase ventilation for cold markets	<input checked="" type="checkbox"/> <b>CRUISEC</b>	Cruise control, standard
<input checked="" type="checkbox"/> <b>PRIM-EL</b>	Electrical priming pump	<input type="checkbox"/> <b>ESP-BAS1</b>	Electronic Stability Control
<input type="checkbox"/> <b>PRIM-MAN</b>	Manual priming pump	<input type="checkbox"/> <b>ESPC-RO</b>	ESP (Electronic Stability Program) functionality control - Reduced / Off
<input type="checkbox"/> <b>FUEQ-EH</b>	Fuel line electric heater	<input type="checkbox"/> <b>HWSS-ACB</b>	Adaptive cruise control with forward collision warning and advanced emergency braking
<input type="checkbox"/> <b>AF-R</b>	Hot fuel recirculation heated fuel filter	<input type="checkbox"/> <b>HWSS-FCB</b>	Forward collision warning with basic cruise control and advanced emergency brake
<input type="checkbox"/> <b>FUEFE2LW</b>	Large engine mounted dual fuel filter with water separator	<input type="checkbox"/> <b>LSS-DW</b>	Lane departure warning system
<input checked="" type="checkbox"/> <b>FUEFE2SW</b>	Small engine mounted dual fuel filter with water separator		
<input type="checkbox"/> <b>EST-AID</b>	Air inlet manifold starting heater element		
<input type="checkbox"/> <b>220EBH15</b>	220V/1.5Kw electric engine block heater		
<input type="checkbox"/> <b>PTER-100</b>	Rear engine mounted power-take-off with DIN 100 / ISO 7646 flange		
<input type="checkbox"/> <b>PTER-DIN</b>	Rear engine mounted PTO with DIN5462 (female) splined shaft for a close coupled pump. Models with 3 steering axles will use this to drive the steering pump (AUXPSP)		
<input type="checkbox"/> <b>PTER1400</b>	Rear engine mounted power-take-off with SAE 1410 flange		
<input type="checkbox"/> <b>HPE-F101</b>	Parker F1-101, engine mounted, fixed displacement, single flow, engine mounted hydraulic pump		
<input type="checkbox"/> <b>HPE-F41</b>	Parker F1-41, engine mounted, fixed displacement, single flow, engine mounted hydraulic pump		
<input type="checkbox"/> <b>HPE-F51</b>	Parker F1-51, engine mounted, fixed displacement, single flow, engine mounted hydraulic pump		
<input type="checkbox"/> <b>HPE-F61</b>	Parker F1-61, engine mounted, fixed displacement, single flow, engine mounted hydraulic pump		
<input type="checkbox"/> <b>HPE-F81</b>	Parker F1-81, engine mounted, fixed displacement, single flow, engine mounted hydraulic pump		
<input type="checkbox"/> <b>HPE-T53</b>	Parker F2-53/53, engine mounted, Fixed displacement, Twin flow engine mounted hydraulic pump		
<input type="checkbox"/> <b>HPE-T70</b>	Parker F2-70/35, engine mounted, Fixed displacement, Twin flow engine mounted hydraulic pump		

Standard Equipment

Optional Equipment

For more detailed information about cab and powertrain equipment, please refer to separate specification sheets.

For all possible options and combinations of options please consult your Volvo sales contact who can create a specification to match your requirements using the Volvo Sales Support system (VSS).

The factory reserves the right to modify design and change equipment without previous notification. The specification can vary from country to country.

# MODEL RANGE

## FMX13 8x4 Rigid - Rear Air Suspension - N3 Cranked front axles for on road work FM

<input type="checkbox"/> <b>LCS</b>	Lane change support	<input checked="" type="checkbox"/> <b>DST-CF4</b>	Driver seat, comfort, suspended, belt in seat
<input type="checkbox"/> <b>DAS-W</b>	Driver Alert Support system	<input type="checkbox"/> <b>DST-CF5</b>	Driver seat, comfort, suspended, belt in seat, electrically heated
<input type="checkbox"/> <b>RSENS-W</b>	Rain sensing windscreen wipers	<input type="checkbox"/> <b>DST-CF6</b>	Driver seat, comfort, suspended, belt in seat, electrically heated, ventilated
<input type="checkbox"/> <b>CU-ECC</b>	Electrically controlled air conditioning with sun sensor	<input type="checkbox"/> <b>SBD-RED</b>	Red seat belts
<input type="checkbox"/> <b>CU-ECC2</b>	Electrically controlled air conditioning with sun sensor, mist sensor, air quality sensor and carbon filter	<input type="checkbox"/> <b>SBPRE-DS</b>	Driver seat belt pretensioner
<input checked="" type="checkbox"/> <b>CU-MCC</b>	Climate unit with manual controlled air conditioning	<input checked="" type="checkbox"/> <b>PST-BAS1</b>	Passenger seat - Fixed non suspended fold up with seatbelt mounted in cab
<input checked="" type="checkbox"/> <b>IMMOBIL</b>	Thatcham H2 approved immobiliser	<input type="checkbox"/> <b>PST-BENC</b>	Bench passenger seat
<input type="checkbox"/> <b>ALARM-B</b>	Thatcham H1 approved vehicle alarm - Cab only	<input type="checkbox"/> <b>PST-CF4</b>	Passenger seat - Comfort suspended with seatbelt mounted in seat
<input type="checkbox"/> <b>ALARM-E</b>	Enhanced vehicle alarm - Thatcham H1 approved - Cab plus external sensor for body/trailer	<input type="checkbox"/> <b>PST-CF5</b>	Passenger seat - Comfort suspended & heated with seatbelt mounted in seat
<input type="checkbox"/> <b>ALCOLOCK</b>	Alcolock	<input type="checkbox"/> <b>PST-STD2</b>	Passenger seat - Fixed non suspended with seatbelt mounted in cab
<input type="checkbox"/> <b>PHONE-PK</b>	Telephone preparation kit (antenna, antenna attachm. cable incl.)	<input type="checkbox"/> <b>PST-STD4</b>	Passenger seat - Standard suspended with seatbelt mounted in cab
<input type="checkbox"/> <b>WLIFT-AD</b>	Electrical window lift, automatic up/down driver side	<input type="checkbox"/> <b>SBPRE-PS</b>	Passenger seat belt pretensioner
<input checked="" type="checkbox"/> <b>WLIFT-EB</b>	Electrical window lift	<input type="checkbox"/> <b>ARM-DBPS</b>	Two armrests on driver seat and one (outer) on passenger seat
<input type="checkbox"/> <b>WLIFT-ME</b>	Mechanical window lift	<input type="checkbox"/> <b>ARMRE-BB</b>	Two armrests on both driver and passenger seat.
<input type="checkbox"/> <b>ISUNS-BS</b>	Side interior sun visor on both sides	<input type="checkbox"/> <b>ARMRE-DB</b>	Two armrests, on driver seat only
<input checked="" type="checkbox"/> <b>ISUNS-DS</b>	Driver's side interior sun visor	<input type="checkbox"/> <b>ARMRE-PB</b>	Two armrests, on passenger seat only
<input checked="" type="checkbox"/> <b>ISUNF-B</b>	Interior front sun visor without mirror	<input type="checkbox"/> <b>ARMRE-PS</b>	Single armrest (next to driver) on passenger seat
<input type="checkbox"/> <b>ISUNF-MD</b>	Interior front sun visor with mirror on driver side	<input type="checkbox"/> <b>ARU-BAS</b>	Vinyl upholstered armrest
<input type="checkbox"/> <b>ISUNF-RE</b>	Electrically operated textile interior sun blind	<input type="checkbox"/> <b>ARU-LEA</b>	Leather upholstered armrest
<input type="checkbox"/> <b>ISUNF-RM</b>	Manually operated textile interior sun blind	<input checked="" type="checkbox"/> <b>FMAT-RU2</b>	Rubber floor mats, extended
<input checked="" type="checkbox"/> <b>CSPU-S</b>	One open storage (behind push open lid) in upper part of dash panel center section	<input type="checkbox"/> <b>FMAT-RUB</b>	Rubber floor mats
<input type="checkbox"/> <b>ADFS</b>	Two extra DIN slots in front shelf - can be fitted with card or drawer available as an accessory	<input type="checkbox"/> <b>FMAT-T2E</b>	
<input checked="" type="checkbox"/> <b>BUPALARM</b>	Reverse alarm	<input type="checkbox"/> <b>FMAT-TX2</b>	Textile and rubber floor mats
<input type="checkbox"/> <b>BUPMON</b>	Back up monitor with built in 7" screen on dash and one colour camera supplied loose for fitment by bodybuilder.	<input type="checkbox"/> <b>LBK-RES</b>	Foldable rest bunk
<input type="checkbox"/> <b>RTOLL-PK</b>	Road toll PREPARATION kit for trucks operating with "Toll Collect" in Germany	<input type="checkbox"/> <b>LBK70</b>	Lower bunk 700 x2000 mm, fixed
<input type="checkbox"/> <b>LOADIND</b>	Load indicator with central dashboard display	<input checked="" type="checkbox"/> <b>ULBK</b>	Without lower bunk
<input type="checkbox"/> <b>REMC-MF</b>	Multi-functio wireless remote control	<input type="checkbox"/> <b>MATL-FI</b>	Firm lower bunk pocket sprung mattress
<input type="checkbox"/> <b>FIREXT3S</b>	3kg fire extinguisher mounted on seat base	<input type="checkbox"/> <b>MATL-SF</b>	Lower flexizone mattress - semi-firm, pocket springs up to 100kg - 16 stone
<input type="checkbox"/> <b>WARNVEST</b>	High visibility warning vest - no sleeves	<input type="checkbox"/> <b>MATL-SO</b>	Lower flexizone mattress - soft, pocket springs up to 85kg - 13.5 stone
<input type="checkbox"/> <b>AIDKIT</b>	First aid kit	<input type="checkbox"/> <b>OLMAT-BA</b>	35mm mattress overlay protector
<input type="checkbox"/> <b>AIDKIT1B</b>	First aid kit	<input type="checkbox"/> <b>OLMAT-PR</b>	50mm premium mattress overlay protector
<input type="checkbox"/> <b>WARNLAMP</b>	Portable warning lamp	<input type="checkbox"/> <b>TBK60F</b>	Fixed foldable top bunk 600 x 1900mm
<input type="checkbox"/> <b>LAMP-IN</b>	Inspection lamp	<input type="checkbox"/> <b>TBK70F</b>	Fixed foldable top bunk 700 x 1900mm
<input type="checkbox"/> <b>BULBKIT</b>	Bulb and fuse kit	<input type="checkbox"/> <b>PH-CAB2</b>	1.8kW Air to air night heater
<input type="checkbox"/> <b>WRITEPAD</b>	Writing pad	<input type="checkbox"/> <b>PH-ENGCA</b>	Engine and cab night heater
<input type="checkbox"/> <b>UPHTRI10</b>	Seats: Black embossed textile insert with light grey sides, black vinyl side bolster with blue vinyl side insert. Interior trim: Raven black bunk and curtains & blue textile side walls	<input type="checkbox"/> <b>PH-SS</b>	Short stop heater
<input checked="" type="checkbox"/> <b>UPHTRI11</b>	Seats: Light grey embossed textile insert, black raven metallic vinyl bolster with red vinyl side insert. Interior trim: Raven black bunk and curtains & grey vinyl side walls	<input type="checkbox"/> <b>SLCP-BAS</b>	Basic sleeper control panel - includes interior light, parking heater, roof hatch and door lock
<input type="checkbox"/> <b>UPHTRI12</b>	Seats: Blue soft textile insert, black vinyl bolster. Interior trim: Raven black bunk and curtains & blue textile side walls	<input type="checkbox"/> <b>SAFE</b>	Safe box for driver's personal items
<input type="checkbox"/> <b>UPHTRI13</b>	Seats: Dark grey leather insert and black leather bolster. Interior trim: Raven black bunk and curtains & grey vinyl side walls	<input type="checkbox"/> <b>ETSB-F</b>	Storage on engine tunnel - on front top
<input type="checkbox"/> <b>UPHTRI14</b>	Seat: Dark grey leather insert and black leather bolster. Interior trim: Raven black bunk and curtains & blue textile side walls	<input type="checkbox"/> <b>ETSB-FR</b>	Storage on engine tunnel - on front top and at rear cab wall
		<input type="checkbox"/> <b>ETSB-FRS</b>	Storage on engine tunnel - on front top & at rear cab wall & storage recessed into tunnel on right hand side
		<input type="checkbox"/> <b>ETSB-FS</b>	Storage on engine tunnel - on front top and storage recessed into tunnel on right hand side
		<input type="checkbox"/> <b>ETSB-R</b>	Storage on engine tunnel - box at rear cab wall
		<input type="checkbox"/> <b>ETSB-RS</b>	Storage on engine tunnel - at rear cab wall and storage recessed into tunnel on right hand side
		<input type="checkbox"/> <b>ETSB-S</b>	Storage on engine tunnel - recessed into tunnel on right hand side
		<input type="checkbox"/> <b>RUS-BAS</b>	Rear cab upper storage 154 litres - 300 mm high
		<input type="checkbox"/> <b>RUS-HIG</b>	Rear cab upper storage 245 litres - 440 mm high
		<input type="checkbox"/> <b>TABLE</b>	Folding and height adjustable table - on lower bunk
		<input type="checkbox"/> <b>REF-ICPK</b>	Refrigerator preparation kit, engine tunnel mounted
		<input type="checkbox"/> <b>REFR-RUS</b>	28 litre rear upper wall mounted refrigerator with dividers
<input checked="" type="checkbox"/> <b>Standard Equipment</b>		<input type="checkbox"/> <b>Optional Equipment</b>	

For more detailed information about cab and powertrain equipment, please refer to separate specification sheets.

For all possible options and combinations of options please consult your Volvo sales contact who can create a specification to match your requirements using the Volvo Sales Support system (VSS).

The factory reserves the right to modify design and change equipment without previous notification. The specification can vary from country to country.

# MODEL RANGE

## FMX13 8x4 Rigid - Rear Air Suspension - N3 Cranked front axles for on road work FM

- BOTH-D** One bottle holder under dashboard centre section
- COFMA-PK** Coffee maker, preparation kit.
- INLI-BAS** Basic white interior lights
- INLI-NL** Interior white and red night light with no dimmer
- INLI-NLD** Interior white and red night light with dimmer function
- ARL-FLEX** Two flexible reading lamps (snake lamps)
- RH-EE** Without roof hatch
- RH-ETR** Roof & escape hatch - Electrically operated, tinted glass with rear opening
- RH-MSR** Steel roof hatch - Manually operated with rear opening
- RH-MTR** Roof & escape hatch - Manually operated, tinted glass with rear opening
- URH** Without roof hatch
- SWIND-BS** Extra side window on both sides behind "B" pillar
- SWIND-PS** Rear side window, passenger side
- VANMIR** Vanity mirror in front shelf
- AS-FUS** Extra shelf in front upper storage compartments
- INFOT-PK** Preparation kit for the mounting of a flat screen TV in cab above the driver's door, includes bracket, electrical and speaker connections

### CAB EXTERIOR

- PAICS-B** Basic cab paint - mirrors, sunvisor, instep and bumper supplied in natural finish - grey
- GLAS-TIN** Tinted windows.
- AWIND-RF** Rear window
- DGLAS-L** Laminated door glass
- LOCK-MAN** Manual door locking
- LOCK-MRP** Manual door locking with internal remote control (from driver side) of passenger door
- LOCK-REM** Central locking with remote control
- BUMP-HD** Heavy duty front bumper
- GUARD-EH** Engine guard to protect sump and engine hoses
- BUGNET** Insect screen in front of radiator
- CTILT-P-E** Electrically operated hydraulic cab tilt
- CTILT-P-M** Manually operated hydraulic cab tilt
- FCABS-A** Front cab - Air suspension
- FCABS-M** Front cab - Mechanical spring suspension
- RCABS-A** Rear cab suspension - Air
- RCABS-M** Rear cab suspension - Mechanical spring
- MIRCOMFX** Electrically heated and operated exterior mirrors with wide angle mirror on both sides and kerb view mirror on passenger side
- MIRSTDX** Electrically heated exterior mirrors with wide angle mirror on both sides and kerb view mirror on passenger side
- AMIR-F20** Auxiliary front view mirror with a 200mm radius
- SUNV-H** External smoke grey sunvisor
- AD-ROOF** Roof air deflector
- AD-SIDEL** Side air deflector extension panels
- AD-SIDES** Short cab side air deflector for rigid bodywork
- HL-BAS2** Halogen H1 head lamps
- HL-BASIC** Halogen H7 head lamps
- HL-BHID2** Dynamic high intensity Bi-Xenon head lamps  
These follow the steering movement and direction of the truck
- HL-CLEAN** Head lamp cleaner - washer jets
- HLP-ST** Headlamp protection
- HL-ADJ** Adjustable headlights with switch in the cab
- ASL-RF2** Two Hella H11 70W spotlamps in sign box - only available with

Standard Equipment

Optional Equipment

For more detailed information about cab and powertrain equipment, please refer to separate specification sheets.

For all possible options and combinations of options please consult your Volvo sales contact who can create a specification to match your requirements using the Volvo Sales Support system (VSS).

The factory reserves the right to modify design and change equipment without previous notification. The specification can vary from country to country.

- ASL-RFPK** the basic headlight and no lower driving lights. Preparation kit for two spotlamps in sign box
- BEACO2F** Two front roof mounted amber beacon rotating warning lamps
- BEACO2R** Two rear roof mounted (on accessory bracket) amber beacon flashing warning LED lamps
- BEACON-P** Roof beacon wire preparation
- BEACONA4** Four roof mounted (2 front/2 rear) amber beacon rotating warning lamps
- CABPT-R1** Single outlet for roof mounted accessories
- CABPT-R2** Twin outlets for roof mounted accessories.
- SPOTP-F** Spotlamp preparation in front, max 280W
- SPOTP-R** Spotlamp preparation on roof, max 280W
- SPOTP-RF** Spotlamp preparation on cab roof and in cab front, max 2x280W
- CSGN-FMX** "Volvo FMX" headboard logo
- HORN-F1S** Single tone Jericho air horn chassis mounted
- HORN-R2S** Two roof mounted air horns
- ANT-CBR** Roof mounted antenna for CB radio, single aerial
- ACCBR-AP** Front, middle & rear roof mounted accessory brackets
- ACCBR-F** Front roof mounted accessory bracket
- ACCBR-FM** Front & middle roof mounted accessory brackets
- ACCBR-FR** Front & rear roof mounted accessory brackets
- ACCBR-M** Middle roof mounted accessory bracket
- ACCBR-R** Rear roof mounted accessory bracket
- ACCBR-RM** Rear & middle roof mounted accessory brackets
- REFS-TW** White cab conspicuity markings by packed in cab
- REFS-TY** Yellow cab conspicuity markings by packed in cab

### SUPERSTRUCTURE PREPARATIONS

- BP-MI02**
- BP-TI03**
- SRWL-PK** Wiring preparation for side & rear work/reverse lamps on side of chassis and a three-position switch, maximum 280W
- SWL-2FW** Two H3 70W white front chassis mounted (LH/RH side) working lamps and a 2-position switch (On/Off)
- SWL-2RW** Two H3 70W white rear chassis mounted (LH/RH side) working lamps and a 2-position switch (On/Off)
- SWL-4W** 4 H3 70W white front (2) & rear (2) chassis mtd (LH/RH side) working lamps & 2-pos switch (On/Off)
- SWL-PK** Wiring preparation for side work/reverse lamps on side of chassis and a three-position switch, maximum 280W
- WLC-H2A** Two H3/70W working lamps with amber coloured lens high mounted back of cab
- WLC-H2W** Two H3/70W white working lamps high mounted on the back of cab
- WLC-PKCH** Preparation kit (cables and switch) for cab mounted chassis working lamp
- WLC-PKH** Preparation kit, cables and switch for high mounted working lamps back of cab
- WLC-PKL** Preparation kit, cables and switch for low mounted working lamps back of cab
- WLC-PKLH** Preparation kit - cables and switch for low and high mounted working lamps back of cab.
- ECBB-BAS** Body builder electrical centre without body builder module
- ECBB-HIG** Body builder electrical centre with body builder module
- BBCHAS1** One 7-pole connector for Body builder interface
- BBCHAS3** Three 7-pole connectors for Body builder interface
- BEPR-T2** Body builder electrical software preparation for tipper with remote control
- EXSTER** External steering control, with VDS and bodybuilder module
- TD-BAS** Trailer detection WITHOUT LED sensing
- TD-LED** Trailer detection with LED sensing
- FRFS-B5** Frame rail free space on both sides to give space for crane legs or other equipment.
- FBA-BTF** Lower front body attachments for torsionally flexible - platform

# MODEL RANGE

FMX13 8x4 Rigid - Rear Air Suspension - N3 Cranked front axles for on road work FM

---

- **FBA-BTSF** body  
Lower front body attachments for torsionally semi-flexible body  
- box or curtainsider
- **HBA-FSFB** Holes for body attachments - flexible/semi-flexible body
- **HBA-SB** Holes for body attachments - stiff body
- **RBA-T2** Lower rear body attachments for helper frame
- **CRANEPK1** Crane plates mounted to frame, for cranes up to 10 tonne  
metre capacity
- **CRANEPK2** Crane plates mounted to frame, for cranes up to 20 tonne  
metre capacity
- **CRANEPK4** Crane plates mounted to frame, for cranes up to 40 tonne  
metre capacity
- **AUXL-SPK** Electrical preparation kit - wiring and switch for snow plough  
lights
- **TAILPRE2** Tail lift preparation kit, wireless remote operation
- **TAILPREP** Taillift preparation kit - cab switch and warning in driver display
- **AESW2** Two Body builder bistable electrical switches (marked AUX1 /  
AUX2)
- **AESW2PK** 2 Body builder bistable el.switches (marked AUX1/AUX2) and  
prep. for 4 more switches
- **AUXSW-4** Wiring for 4 extra switches (from Body builder electrical centre  
to switch positions)

## DELIVERY SERVICES

- **TGW-3GWL** Telematics gateway with GSM/GPRS/3G modem and wireless  
lan WLAN
- **FMS-PK** Fleet Management System gateway
- **DRUT** "My Truck App" Two years subscription to driver utility  
application

**VOLVO**

Volvo Truck Corporation

volvotrucks.com