

I.C. counterbalanced forklift truck

I.C. counterbalanced forklift truck, full-free-view mast lifting from 3.000 to 6.000 mm, side-shift, power steering, steering column multiple adjustable, Automatic transmission. Motor Euro 3. Standard equipped with lighting, driving direction inverter at steering column, comfort driver seat enabled to absorb and limit the vibrations.

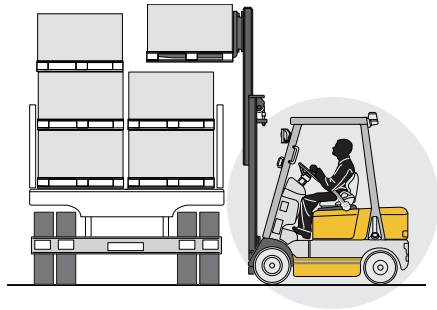

OMG S.p.A.
via dell'Artigianato, 12
46023 - GONZAGA (MN) Italy
Tel. + 39 0376 52.60.11
Fax. + 39 0376 58.80.08
www.omgindustry.com
info@omgindustry.com



Azienda Certificata
ISO 9001:2008 N°7236 MN
ISO 9001:2008 N°23355

• Ergos 15 D-G

Characteristics			OMG S.p.A.			
			ERGOS 15 D	ERGOS 15 G		
1.1	Manufacturer		D			
1.2	Manufacturer's model designation		G			
1.3	Drive : D (diesel) G (lpg)		D			
1.4	Type of control : S (steering wheel) R (seated)		S / R			
1.5	Load capacity	Q (t)	1.5			
1.6	Load centre distance	c (mm)	500			
1.8	Load distance, centre of drive axle to fork	X (mm)	425			
1.9	Wheelbase	Y (mm)	1.350			
Weight	2.1	Service weight	Kg	3.000	2.920	
	2.2	Axle loading (with load)	front / rear	Kg	3.868 / 602	
	2.3	Axle loading (without load)	front / rear	Kg	1.182 / 1.818	
Wheels - Chassis	3.1	Tyres : se (superelastic) cu (cushion) pn (pneumatic)	se / pn			
	3.2	Front wheels size	mm	6.50 - 10 - 10		
	3.3	Rear wheels size	mm	5.00 - 8.8		
	3.5	Wheels : number front / rear (x = traction)	2 / 2			
	3.6	Track width, front	b 10 (mm)	885		
3.7	Track width, rear	b 11 (mm)	900			
Dimensions	4.1	Mast tilting forward / backward	a / b	6 / 12		
	4.2	Lowered mast height	h1 (mm)	2.150		
	4.3	Free lift	h5 (mm)	/		
	4.4	Lifting height	h3 (mm)	3.265		
	4.5	Extended mast height	h4 (mm)	4.520		
	4.7	Overhead guard (cab)	h6 (mm)	2.070		
	4.8	Seat height	h7 (mm)	1.110		
	4.12	Coupling height	h10 (mm)	220		
	4.19	Total length	l1 (mm)	3.435		
	4.20	Length to forks face	l2 (mm)	2.235		
	4.21	Overall width	b1 / b2 (mm)	1.065		
	4.22	Forks dimensions	s / e / l	35 / 100 / 1.200		
	4.23	Fork carriage Class / Type A, B	II A			
	4.24	Fork carriage width	b3 (mm)	1.024		
4.31	Ground clearance, under the mast	laden	m1 (mm)	127		
4.32	Ground clearance, centre of wheelbase	laden	m2 (mm)	176		
4.33	Aisle width with pallets 1000 x 1200 forking side 1200	Ast3 (mm)				
4.34	Aisle width with pallets 800 x 1200 forking side 800	Ast3 (mm)				
4.35	Turning radius	Wa (mm)				
4.36	Smallest pivot point distance	b13 (mm)				
Performances	5.1	Travel speed	laden / unladen	Km / h		
	5.2	Lifting speed	laden / unladen	m / s		
	5.3	Lowering speed	laden / unladen	m / s		
	5.5	Drawbar pull (a 2 Km/h)	laden / unladen	N	14.200 / 14.100	9.200 / 9.000
	5.7	Gradient performance (a 2 Km/h)	laden / unladen	%	26	20
	5.9	Acceleration time (10 m)	s			
	5.10	Service brake M (mechanical) I (hydraulic)	M - I			
	Motor	7.1	Manufacturer / type	YANMAR 4TNE92	NISSAN K-21	
		7.2	Engine power	KW	33.4	32
		7.3	Rated speed	rpm	2.725	3.200
7.4		Number of cylinders / cubic capacity	cm ³	4 / 2.659	4 / 2.065	
7.5		Fuel consumption according to VDI cycle	l / h	2.5	2.4	
Others	8.1	Type of drive control	powershift 1/1			
	8.2	Operation pressure for attachments	bar	175		
	8.3	Oil volume for attachments (max available)	l / min			
	8.4	Sound level at driver's ear	dB (A)	90		
	8.5	Tow coupling, type DIN				

Technical specification according VDI 2198

Information and data are given for information only, OMG S.p.A. will have the sole right for technical changes and improvements without giving any notice.

working lights	s	front twin tyres	o
flashing beacon	s	wider fork holder plate	o
reverse buzzer	s	complete metal cabin	o
vertical exhaust pipe	s	half cabin	o
2 driving mirrors	s	half cabin with PVC doors	o
suspended comfort seat	s	heating system	o
side-shift	s	air conditioning system	o
3rd. hydraulic function	s	hose set for 4th hydraulic function	o
s=standard		o=option	

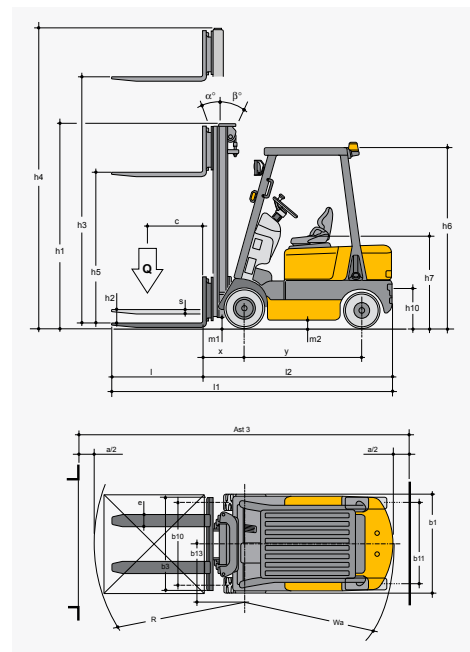

h3		h1	h4	h2	h5	(Q) t c=500 mm	(Q) t c=600 mm
2.965 dx	mm	2.000	4.220	/	1.490	1.5	1.25
3.265 dx	mm	2.150	4.520	/	1.650	1.5	1.25
3.465 dx	mm	2.250	4.720	/	1.750	1.5	1.25
3.965 dx	mm	2.550	5.220	/	2.000	1.5	1.25
4.465 tx ffl	mm	2.100	5.720	/	1.490	1.3	1.05
4.765 tx ffl	mm	2.150	6.020	/	1.600	1.2	1.1
4.965 tx ffl	mm	2.250	6.220	/	1.650	1.0	0.83
5.965 tx ffl	mm	2.650	7.220	/	2.000	0.6	0.5