

Weights

Operating weight with standard bucket, excluding operator	8380 kg
Additional weight for long dipperstick	58 kg
Ground pressure with rubber tracks	38.25 kPa

Engine

Make / model	Yanmar / 4TNV98-ZWDB8
Fuel	Diesel
Number of cylinders	4
Displacement	3300 cm ³
Maximum power at 2000 RPM (DIN 6271)	40.4 kW
Maximum torque at 1300 RPM	248.0 Nm

Performance

Digging force, dipperstick (ISO 6015)	40900 N
Digging force, long dipperstick (ISO 6015)	34100 N
Digging force, bucket (ISO 6015)	54600 N
Drawbar pull	60800 N
Travel speed, low range	2.9 km/h
Travel speed, high range	4.6 km/h

Hydraulic System

Pump type	One engine-driven tandem axial piston pump and one engine-driven gear pump
Piston pump capacity	144.00 L/min
Auxiliary flow	120.00 L/min
System relief pressure for auxiliary circuit 3	280.00 bar
System relief pressure for auxiliary circuit 2	250.00 bar
Auxiliary relief	210.00 bar

Slew System

Boom swing, left	70°
Boom swing, right	55°
Slew rate	9.6 RPM

Fluid Capacities

Cooling system	4.20 L
Engine lubrication plus oil filter	11.60 L
Fuel reservoir	110.00 L
Hydraulic system	127.00 L

Environmental

Noise level LpA(EU Directive 2000/14/EC)	77 dB(A)
Noise level LWA(EU Directive 2000/14/EC)	98 dB(A)

Standard Features

2300 mm dozer blade	Consoles with forwards/backwards adjustable displacement
450 mm steel tracks	Boom load holding valve
Engine/hydraulic monitor with shutdown	Harness for rotating beacon
Fingertip auxiliary hydraulic control	Fully adjustable air conditioning
Control console locks	Overload warning device
Hydraulic joystick controls	Sun visor
Two-speed travel	Left rear view mirror
Lockable storage compartment	Electric refueling pump
Horn	Auto idle
Work lights	Second auxiliary hydraulic line (Rotation piping)
Retractable seat belt	Warranty: 12 months, 2000 hours (whichever occurs first)
Suspension seat with high back	

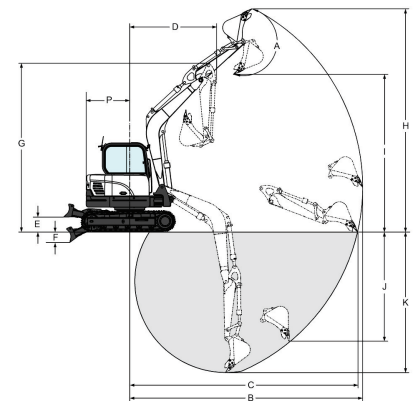
Working Range

(A)	182°	(G)	5019.0 mm
(B)	6965.0 mm	(H)	6715.0 mm
(C)	6765.0 mm	(H*)	7070.0 mm
(C*)	7295.0 mm	(I)	4720.0 mm
(D)	2500.0 mm	(I*)	5085.0 mm
(D*)	2700.0 mm	(J)	3220.0 mm
(E)	438.0 mm	(K)	4150.0 mm
(F)	310.0 mm	(K*)	4675.0 mm

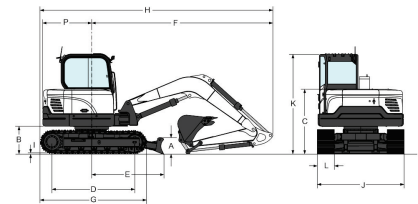
Dimensions

(A)	440.0 mm	(I)	20.0 mm
(B)	737.0 mm	(J)	2300.0 mm
(C)	1715.0 mm	(K)	2638.0 mm
(D)	2200.0 mm	(L)	450.0 mm
(E)	1912.0 mm	(M)	655.0 mm
(F)	4797.0 mm	(N)	803.0 mm
(G)	2823.0 mm	(O)	2500.0 mm
(H)	6167.0 mm	(P)	1298.0 mm
(H*)	6260.0 mm	(Q)	2450.0 mm

Options

Rubber tracks	Long dipperstick
Third auxiliary hydraulic line (Clamshell Piping)	