

* | 345 kW (463 HP) at 1800 rpm

▲ | 71564 - 73624 kg

📏 | 3.00 - 4.50 m³



DX700LC | Crawler Excavator



A close-up photograph of an orange Doosan DX700LC excavator bucket filled with large, light-colored rocks. The bucket is positioned in the foreground, and the excavator's arm is visible. In the background, another orange excavator is working on a rocky hillside under a clear blue sky. The Doosan logo is visible on the side of the excavator's body.

DX700LC

DOOSAN

Take a tour	pages 4 - 5
Performance	pages 6 - 7
Comfort	pages 8 - 9
Control	pages 10 - 11
Reliability	pages 12 - 13
Maintenance	pages 14 - 15
Technical specifications	pages 16 - 22
Equipment	pages 23



ROCK SOLID PERFORMER

A NEW PARTNERSHIP – ALL-OUT PERFORMANCE AND LONG-TERM STRENGTH

Your profits depend on the **quality** of your equipment. You need **massive power** to handle the **toughest jobs**. Long-lasting **durability**. Reliable performance so you can be sure of getting the job done on time. **State-of-the art technology** for smooth, fast production.

The new DX700LC combines all these, and more, to offer you a real improvement in your productivity and an excellent return on your investment.

TAKE A TOUR

Large, heavy-duty boom and arm for more reliability and strength

DOOSAN

Cab top/front guards standard

Great bucket and arm breakout forces of 350.1 and 328.5 kN

All-round visibility for more peace of mind

Highly durable buckets with reinforced side wear plates & hardened cutting edge

TOTAL CONTROL

- Easy access to all controls
- Joysticks and switches integrated in armrest for precise operation
- 7" TFT LCD new user-friendly colour monitor with full access to machine settings and maintenance data
- Rear camera and large side mirrors

Heavy-duty chain and running gear normally associated with 80+ ton excavators

UNBEATABLE STRENGTH

- Heavy-duty X-shaped undercarriage with integrated track spring and idler plus durable box section track frame
- 4 m wide undercarriage for extra stability (3.56 m retracted) and drawbar pull of 48.9 ton
- Track roller guard mounted as standard
- Heavy-duty superstructure under cover

Reliable and well protected hydraulic, electric and lubrication routings with simple, optimised layout

COMFORT AT WORK

- Spacious, renowned cab with low noise and vibration levels
- Heated air suspension seat as standard
- Large sun roof for extra overhead visibility
- Air conditioning with climate control
- Extra large door for easy access

BORN TO PERFORM

- DOOSAN DX700LC ISUZU 6-cylinder "Common Rail" engine combined with e-EPOS System (Electronic Power Optimising System) for maximum fuel efficiency
- Auto-idle and deceleration system
- Power boost function, automatic overheating prevention, low oil pressure sensor, engine emergency cut-off switch, auxiliary mode switch and automatic 2-speed adjustment, etc.
- Electronically controlled exhaust gas recirculation with inter-cooler, regulation systems for variable speed fan and hydraulic oil flow plus separate dual fan cooling

Convenient dimensions: shipping height (hose) of 4220 mm and house width of 3410 mm



MAINTENANCE MADE EASY

- Maintenance data available directly from the control panel
- Easy access to all maintenance components
- Double fuel pre-filter with water separator
- Auto grease system for swing mechanism and front attachment
- PC access for maintenance and repairs
- Self diagnosis function
- Reliable Doosan parts

DX700LC

World-leading performance on the toughest job

■ Designed to achieve the highest output

The DX700LC combines the highest performance and durability requirements to maximise your productivity in mass excavation and truck loading operations. It features a robust engine, uniquely optimised for this machine and a range of hard-working features that will push your profits to new heights, time and time again.



THE 6 UNIQUE BENEFITS:

- Power: 463 HP at 1800 rpm
- Lifting: side-lifting capacity of 28310 kg at 4.5 m reach at ground level
- Loading: loads a 40 t Doosan Moxy articulated dump truck in four to six passes
- Excavation: max. bucket breakout force of 350.10 kN
- Traction: tractive effort of 479.50 kN
- Hydraulic tank capacity: 790 l

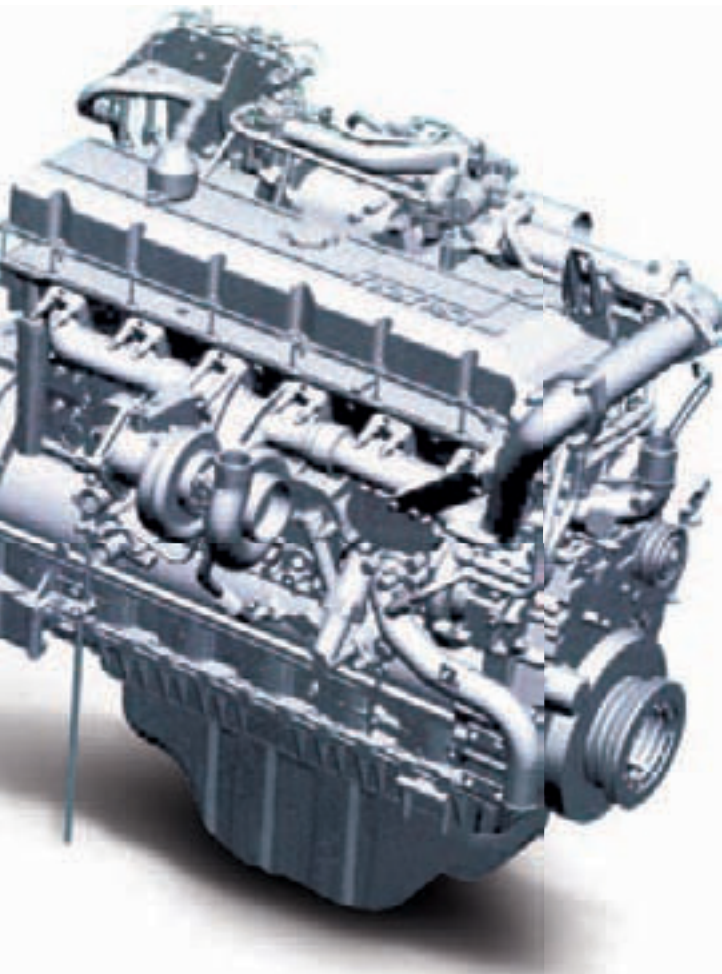

EFFICIENT FUEL AND HYDRAULIC MANAGEMENT

The new DOOSAN DX700LC is powered by a reliable ISUZU 6-cylinder, turbo-charged and water-cooled engine which has been optimised specifically for this machine.

e-EPOS system (Electronic Power Optimising System)

Allows a perfect synchronisation of information between engine and hydraulic systems, offering the ultimate in fuel economy, minimising pollution while providing optimised conversion of engine output in hydraulic performance, higher digging forces and shorter cycle times. e-EPOS also regulates working modes, auto-idle, deceleration, hydraulic flow required by the work group and displays alerts and maintenance data on control panel.

Cooling system

- Doosan Cooling Fan Control (DCFC) controls the fan speed according to coolant temperature and hydraulic oil temperature. The hydraulic oil flow of the cooling fan pump is regulated by an electric signal from the DCFC controller.
- An audible and visible sensor monitors water temperature. This activates the water temperature gauge, the overheat prevention system and the automatic warm-up system.
- An overheat prevention system activates a buzzer and warning lamp when the coolant temperature reaches 110°C.

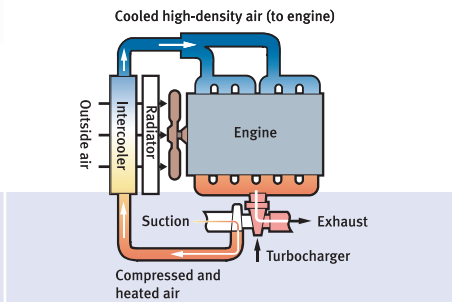
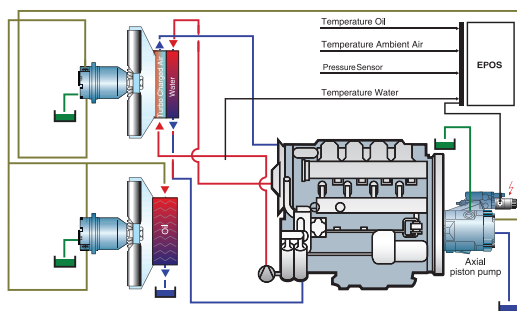

Valve OHC turbo engine with inter-cooler
As air density increases, NOx (Nitrogen Oxide) and PM (Particulate Matter) emissions are reduced substantially. At the same time, fuel economy is improved.

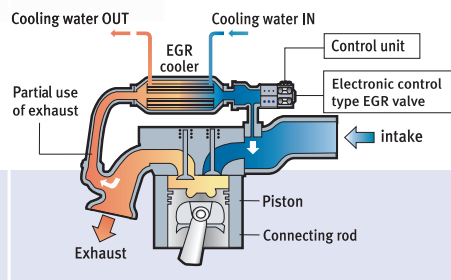

Cooled EGR (Exhaust Gas Recirculation) system
This system lowers the combustion temperature, thus reducing NOx (Nitrogen Oxide)

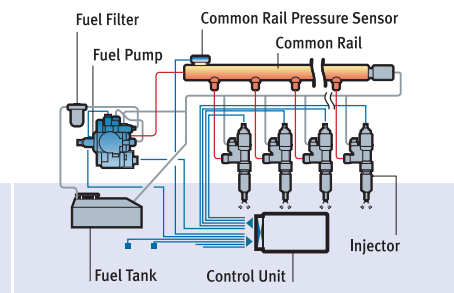

Common Rail high-pressure fuel injection system
High pressure of more than 1600 bar at the rate of 1/1000 second optimises combustion to improve fuel efficiency and reduce PM (Particulate Matter) emissions.



Swing motor
Pressure : 299 kgf/cm²

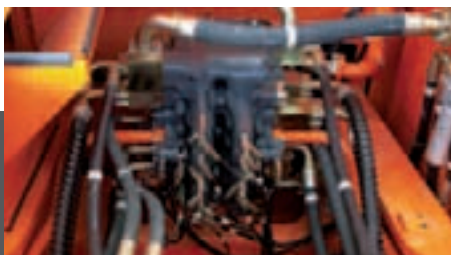

Control valve
• Spool diameter : 35 mm
• Main relief pressure: 320/350 bar



Hydraulic pump
The main pump has a capacity of 2 x 436 l/min

Comfort – renowned cab, the operator’s favourite!

The DX700LC features a sophisticated and spacious cab, designed with the simple aim of providing you with the best possible working conditions. It features a comfortable, adjustable, heated seat and optimal all-round visibility.

To further improve comfort, a number of noise-reduction measures have been introduced throughout the engine, hydraulic equipment, air conditioning, cab damper mounting and cab sealing.

New silent blocs have been fitted, and an innovative hydraulic layout with the pipes fixed under the cab significantly lowers noise in the cab.

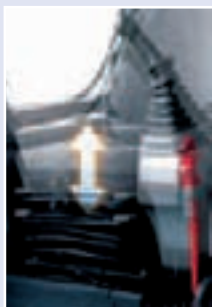

Operator seat (with telescopic function)

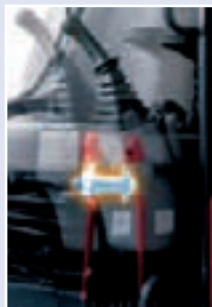

Comfortable 2-stage sliding seat



- Extras:**
- ① Mobile phone box
 - ② Glass antenna
 - ③ Cigarette lighter
 - ④ 12 V power socket



Air conditioning with climate control

The high-performing, electronically controlled air conditioning system features 5 different operating modes allowing the operator to adjust the airflow to suit conditions. A re-circulated air function is also available.

A photo sensor automatically adjusts the air temperature based on the radiant energy detected.

2

1

ERGONOMIC SEAT DESIGN

Easy adjustment for a perfect fit:

Using a dual positioning cursor, you can slide the seat back from the joysticks to set your ideal working position. You can also adjust the reach to the control pedals to match your leg length by sliding the entire seat assembly.

- 1 Large sun roof
- 2 Sun visor
- 3 Straight and ergonomic pedals
- 4 Flat, spacious, easy-to-clean floor
- 5 Upper front window is strut-assisted for easy, reliable adjustment and integrates a sun shade
- 6 Joysticks and switches are integrated in adjustable control consoles

5

6

3

4

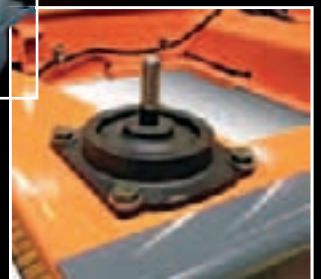
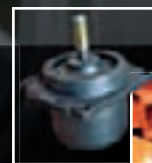

Cab vibration absorbers

The cab is mounted on special viscous vibration isolators which absorb shocks and limit noise for more operator comfort.

Intuitive control for maximum output

Impressive power matched by precise control means that the highest standards of efficiency are just a finger's reach away. The DX700LC offers a unique range of features that make it easy to control all the machine's functions with the precision you need. Highly sensitive joysticks ensure minimum effort. The smooth travel pedal is fitted with a hydraulic damper to improve controllability and feeling during travel, as well as easing starts and stops; just to mention a few...

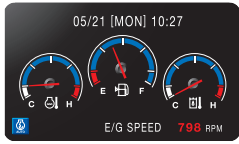

Standard screen



Anti-theft protection

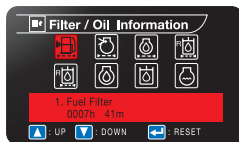

Filter/oil information

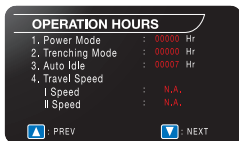

Operation history



Flow rate control

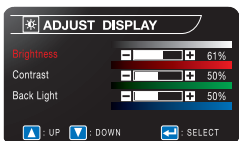

Contrast control



Colour LCD monitor panel

The 7" TFT LCD panel is suitable for day and night work. The monitor is user-friendly and gives full access to machine settings and maintenance data. Any abnormality is clearly displayed on the screen, allowing you to work safely and confidently with an accurate overview of all conditions.

1 Gauges

- Engine coolant temperature
- Fuel
- Hydraulic oil temperature

2 Working modes

- Standard, Power, Economy and Lifting mode
- Auto-idle
- Flow rate control

3 Navigation modes

- Rear view camera
- Display selector
- Select

4 working modes for maximum efficiency

- Standard mode: uses 85% engine power for optimum fuel efficiency when carrying out general work such as heavy-duty dumping and breaker work. Priority is given to control of the boom, swing, etc.
- Power mode: uses 100% engine power for heavy work such as heavy-duty digging and loading.
- Economy mode: uses 74% engine power to reduce fuel consumption without compromising on performance for light work such as medium duty dumping, digging and loading.
- Lifting mode: uses 83% engine power for tasks such as pipe or beam lifting.

Safety matters

- Rear view camera: a clear view of what's happening behind the machine adds safety and peace of mind.
- Cab and boom lights are fitted as standard, greatly enhancing safety during night work.

Additional safety features, also fitted as standard, include: automatic overheating prevention, low oil pressure sensor, engine emergency cut off switch, auxiliary mode switch (to stop the pump when the control system is out of order), and a 2-speed feature which automatically adjusts speed according to the tractive effort.





Easy-reach control panel

Clear controls positioned for convenient access allow you to work safely and confidently.



Simple operation

- Joysticks enable easy, precise control of levelling operations, movement of lifted loads and difficult manoeuvres.
- Buttons integrated on the joysticks are used to operate additional equipment such as grabs, crushers and grapples and to activate the power boost function.



Dynamic power management

- Activation of the power boost control system increases digging power by 10%
- A one-touch deceleration system immediately reduces engine speed to low or idle
- Auto-idling starts after more than 4 seconds at low rpm. This decreases fuel consumption and reduces noise levels in the cab

Reliability – quality components and heavy-duty chain

■ Designed to operate on the toughest terrains

In your profession you need equipment you can depend on. At DOOSAN, we use highly specialised design and analysis tools to make sure our machines are as robust and durable as possible. Our materials and structures undergo severe testing for strength and resilience in the most extreme conditions.

RESILIENT CHAIN FOR 80 TON-CLASS RELIABILITY

The DX700LC is fitted with a super-strong chain featuring components that are typically fitted to 80+ ton excavators. Featuring a 26 cm link pitch, a 5.7 cm pin diameter and heavy-duty running gear, it is designed for a long, trouble-free life, even in rough conditions.

Adjustable track frame and track roller guard as standard

Track frame width with 650 mm shoe:

- Work position (extended w/o steps) : 4000 mm
- Transport position (retracted w/o steps) : 3560 mm
- The superstructure is protected for tough work with a heavy-duty under cover

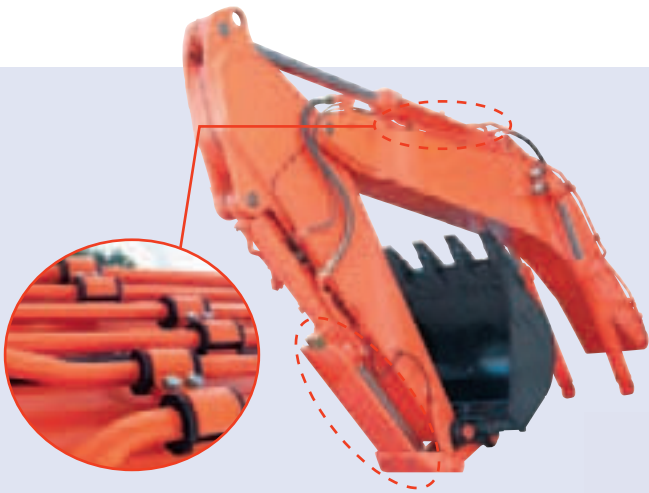
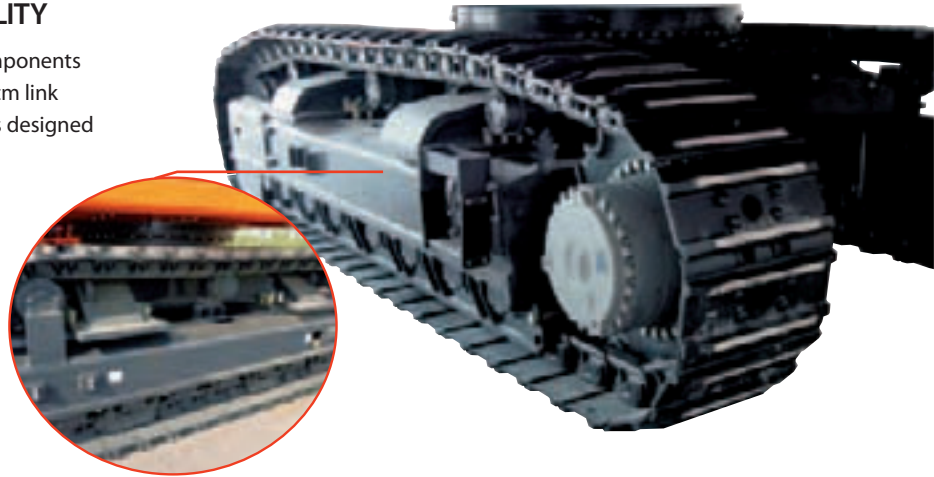

Strengthened boom

Finite Element Analysis (FEA) has been used to calculate the best distribution of loads throughout the boom structure. Combined with increased material thickness, this means that element fatigue is limited and both reliability and component life are increased.

Arm assembly

Cast elements and reinforcements have been added to give the arm assembly greater strength and a longer lifetime.

Better protection for superior durability

The hydraulics layout is straight and simple for a neat, compact design. Boom and bucket cylinder protection guards further increase reliability.



X-chassis

The X-shaped undercarriage has been designed using Finite Element Analysis and 3D computer simulation to ensure optimum structural integrity and durability. The swing gear is solid and stable.



Heavy-duty sprocket

The rugged sprocket design ensures maximum durability no matter what the working conditions.

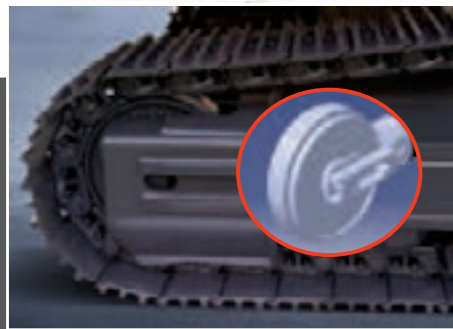

Integrated track spring and idler

The track spring and idler have been joined together for long-lasting performance and convenient maintenance.

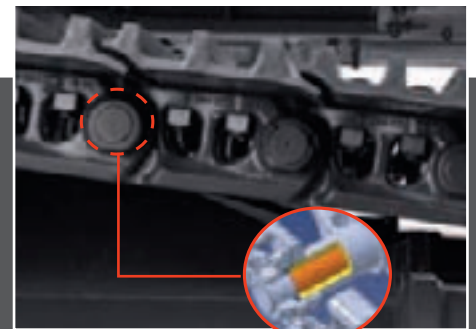

Tracks

For long-term dependability in all conditions, the chain is composed of sealed, self-lubricating links which are isolated from all external contamination. The tracks are locked by mechanically bolted pins.



The heavy-duty undercarriage provides great stability and durability. It is perfectly suited to the toughest working environments.

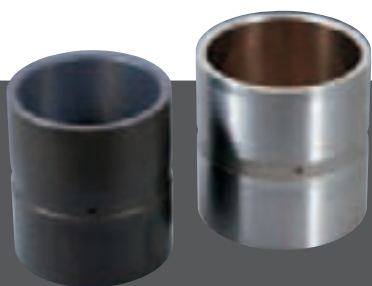

Bushings

A highly lubricated metal is used for the boom pivot in order to increase the component lifetime and extend the greasing intervals to 250 hours. The bucket pivot features a rolled bushing with very fine grooves, only requiring greasing every 50 hours.

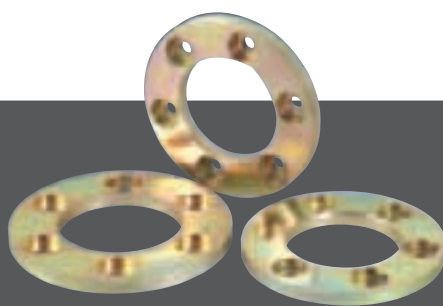

Ultra hard wear-resistant discs

New materials have been used to enhance resistance to wear and to increase service intervals. Wear plates on the inside and the outside of the bucket lugs greatly increase disc lifetime.



Polymer shim

A polymer shim is added to the bucket pivot to maintain precise control over the equipment and extend greasing intervals to 250 hours.

Easy maintenance for less downtime

Short maintenance operations at long intervals mean you can depend on your equipment being available on site when it's needed. As well as being easy to use, the DX700LC was designed for simple maintenance, making it an economical and rewarding choice.



Easy-access doors plus anti-slip steps and platforms

Large doors provide easy access to the various radiators, making cleaning easier. Engine parts can be easily reached via the top and side panels while anti-slip steps and platforms mean maintenance procedures can be carried out more safely.

Air cleaner with pre-cleaner

The large capacity forced air cleaner removes over 99% of airborne particles, reducing the risk of engine contamination and making the cleaning and cartridge change intervals greater.



Protective oil return filter

The protection of the hydraulic system is made more effective by the use of glass fiber technology in the main oil return filter. With more than 99.5% of foreign particles filtered out, the oil change interval is increased.



Engine oil filter

The engine oil filter offers a high level of filtration allowing a long interval of 500 hours between changes. It is easy to access and is positioned to avoid contaminating the surrounding environment.



Double fuel pre-filter with water separator sensor

High efficiency fuel filtration is attained by the use of multiple filters. These include a fuel pre-filter fitted with a water separator that removes moisture, dirt and debris from the fuel. A warning sensor is added to each fuel filter to indicate when water draining is required.

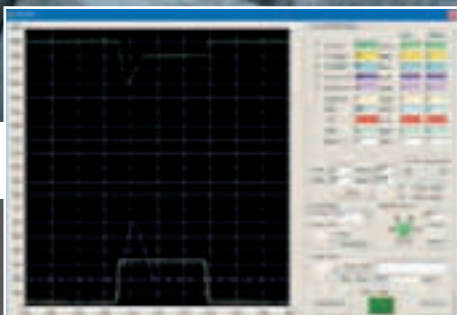

PC monitoring

A PC monitoring function enables connection to the e-EPOS system. Thus, various parameters can be checked during maintenance, including pump pressures, engine rotation and engine speed. These can be saved and printed for analysis.



Convenient fuse box

The fuse box is located in the storage compartment behind the seat for convenient access.



Fuel heater and auto grease system

Standard for swing mechanism and front attachment.

Technical specifications

* Engine

• Model

DOOSAN DX700LC "Common Rail" ISUZU AH-6WG1XYSC-01, water-cooled, direct injection

• No. of cylinders

6

• Nominal flywheel power

345 kW (463 HP) at 1800 rpm (SAE J 1349, net)

• Max. torque

202 kgf/m (1981 Nm) at 1500 rpm

• Piston displacement

15681 cm³

• Bore x stroke

147 mm x 154 mm

• Starter

24 V / 7.0 kW

• Batteries

2 x 12 V / 150 Ah

• Air filter

Double element with pre-cleaner

* Hydraulic system

The brain of the DX700LC is the e-EPOS (Electronic Power Optimising System). It allows the efficiency of the hydraulic system to be optimised for all working conditions and minimises fuel consumption. The e-EPOS is connected to the engine's Electronic Control Unit (ECU) via a data transfer link to harmonise the operation of the engine and hydraulics.

- The hydraulic system enables independent or combined operations.
- Two travel speeds offer either increased torque or high speed.
- Cross-sensing pump system for fuel savings
- Auto-idle system
- Four operating modes
- Button control of flow in auxiliary equipment circuits
- Computer-aided pump power control

• Main pumps

Tandem, Axial Piston	
Maximum flow:	2 x 436 l/min
Displacement:	2 X 242 cm ³ /rev.
Weight:	300 kg

• Pilot pump

Gear pump – maximum flow:	27 l/min
Displacement:	15 cm ³ /rev.
Relief valve pressure:	39.8 kgf/cm ²

• Maximum system pressure

Work/travel:	320 [+10/0] / 350 [+10/0] kg/cm ²
--------------	---

* Weight

Boom: 7700 mm • Arm: 3550 mm • GP Bucket: SAE 3.30 m³ • Counterweight: 11300 kg

	Shoe width (mm)	Operating weight (kg)	Ground pressure (kg/m ²)
Double grouser	650 (std)	70100	1.02
	750	71100	0.91
	900	72100	0.77

* Undercarriage

Very robust construction. All welded structures designed to limit stresses. High-quality, durable materials. Lateral chassis welded and rigidly attached to undercarriage. Track rollers lubricated for life. Idlers and sprockets fitted with floating seals. Track shoes made of induction-hardened alloy with double grouser. Heat-treated connecting pins. Hydraulic track adjuster with shock absorbing tension mechanism

• Number of rollers and track shoes per side

Upper rollers:	3 (standard shoes)
Lower rollers:	8
Shoes:	48
Overall length:	13250 mm
Track length:	5975 mm

* Hydraulic cylinders

Piston rods and cylinder bodies of high-strength steel. Shock-absorbing mechanism fitted in all cylinders for shock-free operation and extended piston life

Cylinders	Quantity	Bore x rod diameter x stroke
Boom	2	190 x 125 x 1795 mm
Arm	1 (1)	215 x 150 x 2030 (1890) mm
Bucket	1 (1)	190 (200) x 130 x 1465 mm

() : opt.

* Environment

Noise levels comply with environmental regulations (dynamic values).

• Noise level LwA

108 dB(A) (2000/14/EC)

• Operator LpA

76 dB(A) (ISO 6396)

* Swing mechanism

- High-torque, axial piston motor with planetary reduction gear in oil bath
- Slew ring: shear-type ball bearing with induction-hardened internal gear
- Internal gear and pinion immersed in lubricant bath
- Swing speed: 7.1 rpm (Eff. = 0.98)
- Max. swing torque: 22,070 kgf/m (Eff. = 0.77)

* Drive

Each track is driven by an independent, high-torque, axial piston motor through a planetary reduction gearbox.

Two levers with control pedals guarantee smooth travel with counter-rotation on demand.

• Travel speed (fast/slow)

4.6/2.8 km/h (Eff. = 97%)

• Maximum drawbar pull

48.9/42.4 ton (Eff.=76.4/65.4%)

• Maximum gradeability

35° / 70%

* Fluid capacities

• Fuel tank

850 l

• Cooling system (radiator capacity)

69 l

• Engine oil

52 l

• Swing drive

2 x 6 l

• Travel device

2 x 20 l

• Oil tank

Level: 390 l

• System (tank full)

790 l

* Buckets

Shoe: 650 mm • Counterweight: 11300 kg

Bucket Type	Capacity (m ³)	Width (mm)	Radius (mm)	Weight (kg)	Teeth	Boom: 6650 mm		Boom: 7700 mm		
						Arm: 2600 mm	Arm: 2900 mm	Arm: 2900 mm	Arm: 3550 mm	Arm: 4200 mm
GP (General Purpose)	2.50	1565	2132	2520	4	A	A	A	A	A
	3.00	1805	2132	2815	5	A	A	A	A	B
	3.30	1944	2132	3020	5	A	A	B	B	C
	3.90	1999	2187	3180	5	A	A	C	C	D
	4.50	2249	2187	3500	6	B	B	D	X	X
HD (Heavy-Duty)	3.00	1676	2146	3310	5	A	A	A	B	C
	3.30	1548	2146	3450	5	A	A	B	C	D
	3.90	1928	2146	3730	5	A	B	C	D	X
	4.50	2180	2146	4090	6	B	C	D	X	X

Recommended sizes are for reference only and are not necessarily available from the factory.

A. Suitable for materials with a density less than or equal to 2100 kg/m³

B. Suitable for materials with a density less than or equal to 1800 kg/m³

C. Suitable for materials with a density less than or equal to 1500 kg/m³

D. Suitable for materials with a density less than or equal to 1200 kg/m³

X. Not recommended

* Digging forces (ISO)

Shoe: 650 mm • Counterweight: 11300 kg

		Boom 7700 - Arm 3550 3.3 m ³ GP bucket	Boom 7700 - Arm 2900 3.3 m ³ HD bucket	Boom 7700 - Arm 4200 3 m ³ GP bucket	Boom 6650 - Arm 2900 3.9 m ³ GP bucket	Boom 6650 - Arm 2600 4.5 m ³ GP bucket
BUCKET (Normal/Press. Up)	ton	32.6/35.7	31.8/34.8	32.6/35.7	36.7/40.1	36.8/40.2
	kN	319.8/350.2	311.9/341.3	319.8/350.2	360/393.3	360/394.3
ARM (Normal/Press. Up)	ton	26.8/29.3	30.7/33.5	24.0/26.2	30.3/33.2	32.3/35.4
	kN	262.9/287.4	301.1/328.6	235.4/257	297.2/325.7	316.9/347.3

Dimensions

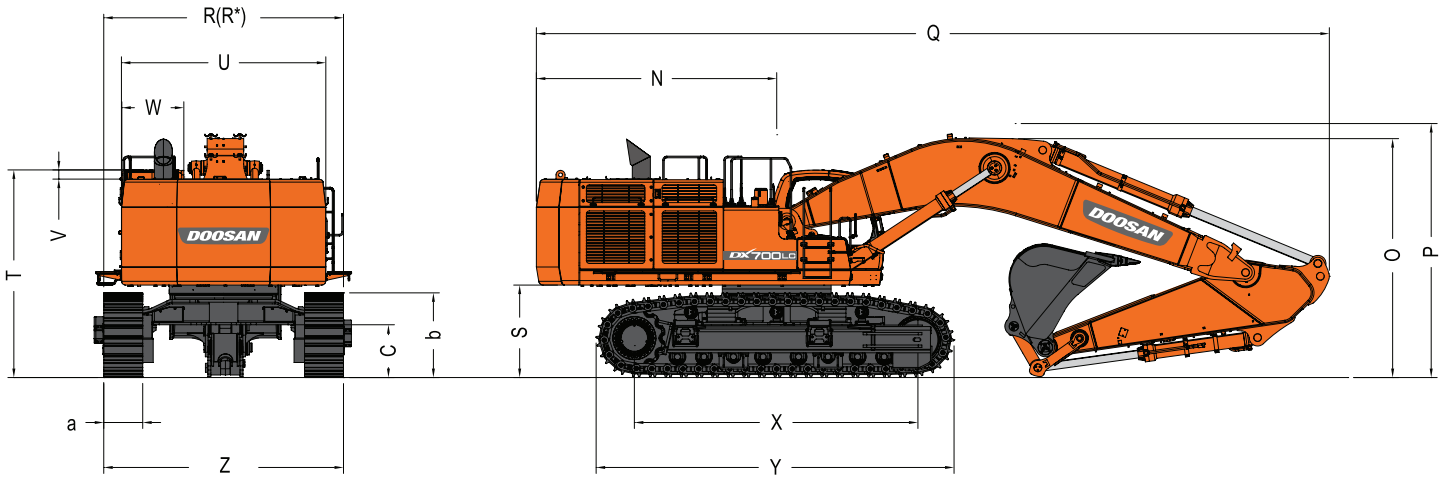

* Dimensions

Boom length (1-piece) - mm		7700			6650	
Arm length - mm		3550	2900	4200	2900	2600
Bucket capacity - m ³		3.30	3.30	3.00	3.90	4.50
N	Tail swing radius - mm	4090	4090	4090	4090	4090
O	Shipping height (boom) - mm	4063	4418	5015	4920	4750
P	Shipping height (hose) - mm	4220	4520	5130	5000	4870
Q	Shipping length - mm	13250	13400	13085	12335	12335
R	Shipping width (std) - mm	3560	3560	3560	3560	3560
R*	Shipping width (narrow) - mm	-	-	-	-	-
S	Counterweight clearance - mm	1525	1525	1525	1525	1525
T	Height over cab - mm	3515	3515	3515	3515	3515
U	House width - mm	3410	3410	3410	3410	3410
V	Cab height above house - mm	208	208	208	208	208
W	Cab width - mm	1010	1010	1010	1010	1010
X	Tumbler distance - mm	4730	4730	4730	4730	4730
Y	Track length - mm	5975	5975	5975	5,975	5975
Z	Undercarriage width (std) - mm	3560 / 4000 †	3560 / 4000 †	3560 / 4000 †	3560 / 4000 †	3560 / 4000 †
a	Shoe width - mm	650	650	650	650	650
b	Track height - mm	1413	1413	1413	1413	1413
c	Ground clearance - mm	870	870	870	870	870

(†) retracted / extended W/O steps

* Components weights & dimensions

Item		DX700LC (kg)	Remarks
Superstructure w/o front		35700	Including counterweight
Counterweight		11300	
Lower structure assembly		20500	
Front assembly		15424	7.70 m boom, 3.55 m arm, 3.30 m ³ GP bucket
Boom	6650 mm	5200	Including bushings
	7700 mm	5440	
Arm	2600 mm	2320	
	2900 mm	2440	
	3550 mm	2480	
	4200 mm	2780	
Bucket	HD 3.30 m ³	3450	
	GP 3.00 m ³	2815	
	GP 3.30 m ³	3020	
	GP 3.90 m ³	3180	
Boom cylinder (each)		565	Φ190xΦ125x1795 mm
Arm cylinder	3.55 m arm	900	Φ215xΦ150x2030 mm
	2.90 m arm	860	Φ215xΦ150x1890 mm
Bucket cylinder	7.70 m boom, 3.55 m arm, 3.30 m ³ GP bucket	540	Φ190xΦ130x1465 mm
	7.70 m boom, 2.90 m arm, 3.30 m ³ HD bucket	570	Φ200xΦ130x1465 mm

(†) retracted / extended W/O steps

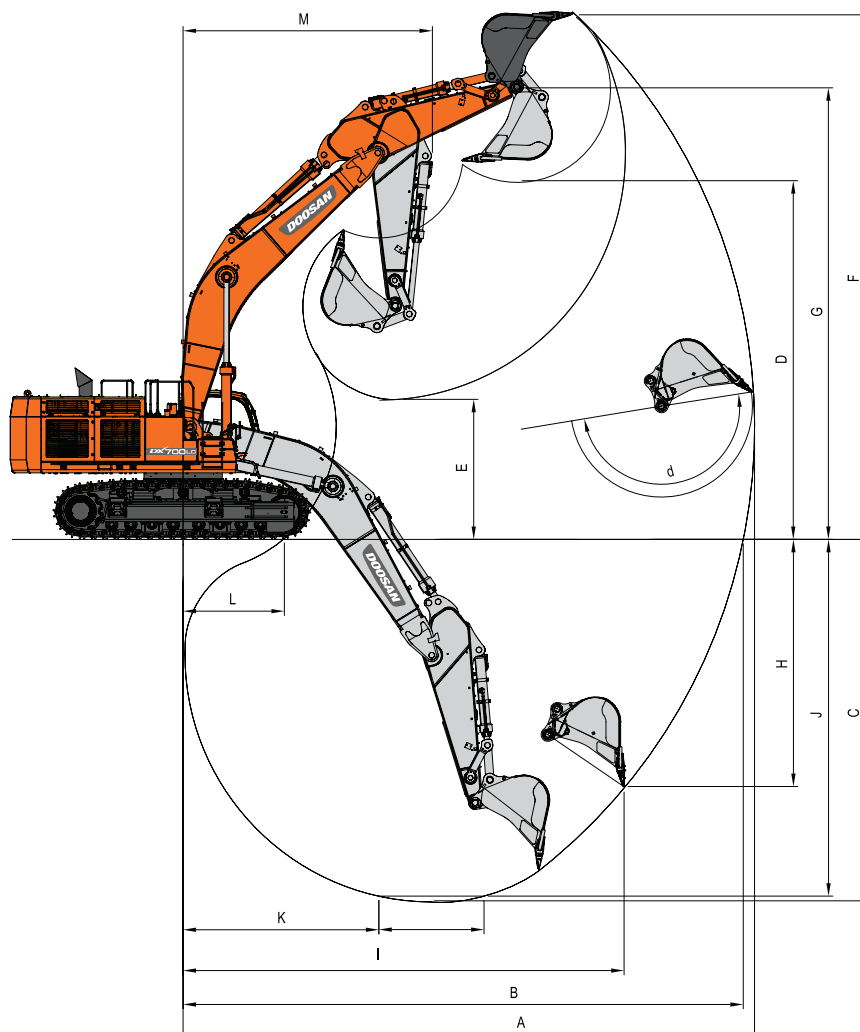

* Working range

Boom length (1-piece) - mm	7700			6650	
Arm length - mm	3550	2900	4200	2900	2600
Bucket capacity - m ³	3.30	3.30	3.00	3.90	4.50
A Max. digging reach - mm	13250	12720	13865	11605	11345
B Max. digging reach at ground level - mm	12990	12450	13610	11305	11040
C Max. digging depth - mm	8410	7730	9030	7075	6780
D Max. dumping height - mm	8320	8220	8660	7020	6940
E Min. dumping height - mm	3248	3950	2630	3080	3380
F Max. digging height - mm	12165	12040	12520	10740	10680
G Max. bucket pin height - mm	10470	10380	10795	9210	9135
H Max. vertical wall depth - mm	5730	4060	6515	3450	3305
I Max. radius vertical - mm	10230	10790	10360	9860	9655
J Max. digging depth - mm	8270	7550	8910	6925	6620
K Min. radius - mm	4540	4530	10360	3800	3785
L Min. digging reach - mm	2350	3060	170	1835	2050
M Min. swing radius - mm	5780	5790	5810	5230	5195
d Bucket angle - (°)	179.4	177.8	179.4	167.4	166.4



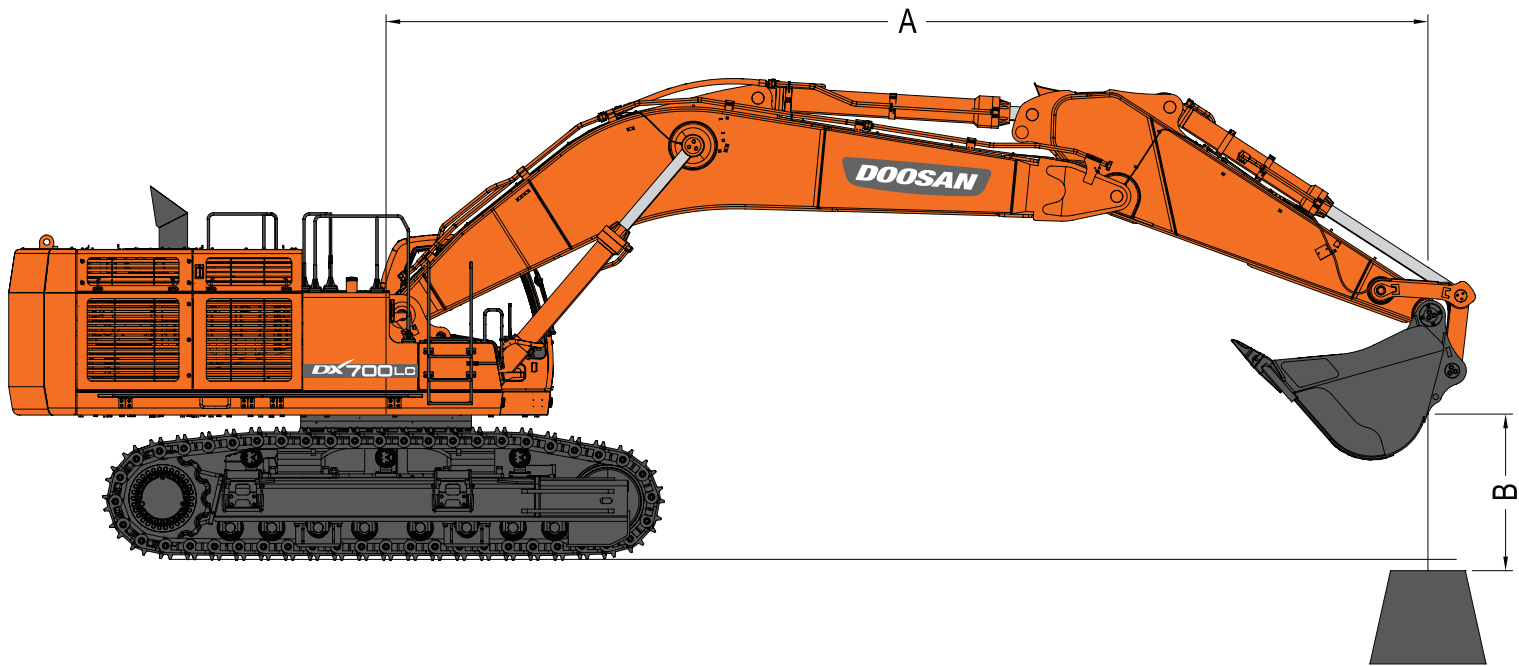













Lifting capacities





Standard configuration

Boom: 7700 mm - Arm: 2900 mm - HD Bucket: SAE 3.30 m³ heaped (CECE 3.00 m³) - Shoe: 650 mm - Counterweight: 11300 kg

Units: 1000 kg

B (m)	A (m)		3		4.5		6		7.5		9		10.5		Max. lift		A (m)
																	
9															10.66 *	10.66 *	8.60
7.5										11.92 *	11.71				10.46 *	10.31	9.55
6								14.17 *	14.17 *	12.40 *	11.35				10.62 *	8.78	10.19
4.5					19.77 *	19.77 *	15.59 *	14.93	13.14 *	10.82	11.59 *	8.00	11.10 *	7.87	11.10 *	7.87	10.58
3					22.17 *	19.81	16.95 *	13.95	13.90 *	10.27	11.90 *	7.73	11.63 *	7.39	11.63 *	7.39	10.74
1.5					23.52 *	18.63	17.91 *	13.18	14.45 *	9.81	11.91	7.49	11.55	7.25	11.55	7.25	10.69
0 (Ground)					23.62 *	18.09	18.21 *	12.72	14.59 *	9.50			11.91	7.45	11.91	7.45	10.42
-1.5			29.07 *	29.07 *	22.62 *	18.01	17.71 *	12.56	14.08 *	9.40			12.10 *	8.07	12.10 *	8.07	9.92
-3	30.81 *	30.81 *	25.80 *	25.80 *	20.52 *	18.26	16.19 *	12.69	12.45 *	9.57			12.07 *	9.36	12.07 *	9.36	9.14
-4.5	24.55 *	24.55 *	20.93 *	20.93 *	16.92 *	16.92 *	13.03 *	13.03 *					11.58 *	11.58 *	11.58 *	11.58 *	8.00
-6					10.46 *	10.46 *							9.59 *	9.59 *	9.59 *	9.59 *	6.32

1. The nominal forces are based on the SAE J1097 standard.
2. The load point is the hook at the rear of the bucket.
3. * = The nominal loads are based on hydraulic capacity.
4. The nominal loads do not exceed 87% of the hydraulic capacity or 75% of the capacity of the swing.
5. For lifting capacity without bucket, simply add actual weight of the bucket from the values.
6. The configurations indicated do not necessarily reflect the standard equipment of the machine.

 : Nominal force
 : Nominal force at the side or 360°

Option 1

Boom: 7700 mm - Arm: 3550 mm - GP Bucket: SAE 3.30 m³ heaped (CECE 2.90 m³) - Shoe: 650 mm - Counterweight: 11300 kg

Units: 1000 kg

A (m) \ B (m)	3		4.5		6		7.5		9		10.5		Max. lift		A (m)
9									9.36 *	9.36 *			8.38 *	8.38 *	9.15
7.5									11.44 *	11.44 *			8.23 *	8.23 *	9.78
6							13.62 *	13.62 *	12.03 *	11.75	9.72 *	8.61	8.34 *	8.34	10.28
4.5			26.60 *	26.60 *	18.99 *	18.99 *	15.16 *	15.16 *	12.88 *	11.20	11.41 *	8.34	8.71 *	7.53	10.65
3					21.70 *	20.62	16.70 *	14.44	13.76 *	10.63	11.85 *	8.02	9.34 *	7.09	10.93
1.5					23.51 *	19.30	17.89 *	13.62	14.47 *	10.12	12.15	7.73	10.31 *	6.94	11.10
0 (Ground)			28.31 *	28.31 *	24.09 *	18.59	18.47 *	13.07	14.81 *	9.76	11.94	7.53	11.27	7.09	10.87
-1.5	24.16 *	24.16 *	31.18 *	30.20	23.53 *	18.35	18.27 *	12.82	14.58 *	9.58			11.81 *	7.61	10.58
-3	32.85 *	32.85 *	28.23 *	28.23 *	21.85 *	18.45	17.14 *	12.83	13.46 *	9.63			11.93 *	8.65	10.18
-4.5	30.06 *	30.06 *	23.82 *	23.82 *	18.80 *	18.80 *	14.66 *	13.14					11.76 *	10.70	9.66
-6			17.10 *	17.10 *	13.53 *	13.53 *							10.71 *	10.71 *	8.99

Option 2

Boom: 7700 mm - Arm: 4200 mm - GP Bucket: SAE 3.00 m³ heaped (CECE 2.70 m³) - Shoe: 650 mm - Counterweight: 11300 kg

Units: 1000 kg

A (m) \ B (m)	1.5		3		4.5		6		7.5		9		10.5		Max. lift		A (m)
9															6.67 *	6.67 *	9.94
7.5															6.51 *	6.51 *	10.78
6											10.55 *	10.55 *	8.17 *	8.17 *	6.56 *	6.56 *	11.35
4.5							17.51 *	17.51 *	14.19 *	14.19 *	12.16 *	11.42	10.83 *	8.49	6.79 *	6.74	11.70
3							20.48 *	20.48 *	15.89 *	14.75	13.17 *	10.80	11.38 *	8.12	7.21 *	6.35	11.84
1.5							22.74 *	19.71	17.32 *	13.83	14.04 *	10.23	11.86 *	7.78	7.87 *	6.21	11.80
0 (Ground)					28.81 *	28.81 *	23.88 *	18.77	18.20 *	13.17	14.60 *	9.79	11.91	7.51	8.85 *	6.32	11.56
-1.5			22.52 *	22.52 *	32.47 *	30.04	23.85 *	18.33	18.35 *	12.79	14.65 *	9.52	11.76	7.37	10.36 *	6.71	11.10
-3	24.86 *	24.86 *	29.49 *	29.49 *	30.12 *	30.12 *	22.70 *	18.28	17.65 *	12.69	13.99 *	9.46			11.02 *	7.51	10.41
-4.5	31.53 *	31.53 *	35.41 *	35.41 *	26.36 *	26.36 *	20.30 *	18.54	15.83 *	12.86	12.13 *	9.66			11.02 *	9.00	9.43
-6			26.54 *	26.54 *	20.65 *	20.65 *	16.11 *	16.11 *	12.12 *	12.12 *					10.52 *	10.52 *	8.07

Option 3

Boom: 6650 mm - Arm: 2900 mm - GP Bucket: SAE 3.90 m³ heaped (CECE 3.46 m³) - Shoe: 650 mm - Counterweight: 11300 kg

Units: 1000 kg

A (m) \ B (m)	3		4.5		6		7.5		9		Max. lift		A (m)		
7.5													10.04 *	10.04 *	8.26
6													10.17 *	10.17 *	8.99
4.5			26.17 *	26.17 *	19.72 *	19.72 *	16.34 *	15.98	14.34 *	11.49	10.70 *	10.49	9.80	9.61	9.43
3					22.46 *	21.83	17.79 *	15.14	15.02 *	11.06	11.65 *	9.80	9.61	9.61	9.61
1.5			34.63 *	32.73	24.45 *	20.54	18.94 *	14.41	15.53 *	10.67	13.18 *	9.62	9.56	9.56	9.56
0 (Ground)			34.68 *	31.87	25.16 *	19.78	19.40 *	13.92	15.52 *	10.41	14.93 *	9.95	9.26	9.26	9.26
-1.5	36.17 *	36.17 *	32.71 *	31.81	24.40 *	19.52	18.81 *	13.72					15.34 *	10.96	8.68
-3	38.29 *	38.29 *	28.79 *	28.79 *	21.90 *	19.70	16.53 *	13.89					15.56 *	13.17	7.78
-4.5	28.12 *	28.12 *	22.07 *	22.07 *	16.56 *	16.56 *							15.02 *	15.02 *	6.40

- The nominal forces are based on the SAE J1097 standard.
- The load point is the hook at the rear of the bucket.
- * = The nominal loads are based on hydraulic capacity.
- The nominal loads do not exceed 87% of the hydraulic capacity or 75% of the capacity of the swing.
- For lifting capacity without bucket, simply add actual weight of the bucket from the values.
- The configurations indicated do not necessarily reflect the standard equipment of the machine.

: Nominal force
 : Nominal force at the side or 360°

Lifting capacities

Option 4

Boom: 7700 mm - Arm: 2900 mm - W/O Bucket - Shoe: 900 mm - Counterweight: 11300 kg

Units: 1000 kg

A (m) \ B (m)	3		4.5		6		7.5		9		10.5		Max. lift		A (m)
9							15.99 *	15.99 *					15.81 *	15.56	8.36
7.5							16.38 *	16.38 *	15.25 *	13.69			15.19 *	12.79	9.34
6					20.83 *	20.83 *	17.49 *	17.49 *	15.57 *	13.42			14.88 *	11.24	9.99
4.5					23.67 *	23.67 *	18.92 *	17.07	16.24 *	13.00			14.74 *	10.35	10.39
3							20.24 *	16.29	16.92 *	12.56	14.46	9.99	14.34	9.91	10.55
1.5							21.05 *	15.72	17.36 *	12.20	14.29	9.83	14.29	9.83	10.50
0 (Ground)					26.56 *	21.21	21.10 *	15.40	17.29 *	11.99			14.65 *	10.12	10.23
-1.5					25.09 *	21.23	20.24 *	15.33	16.40 *	11.97			14.48 *	10.88	9.72
-3	28.80 *	28.80 *	26.91 *	26.91 *	22.44 *	21.50	18.18 *	15.52					13.98 *	12.40	8.92
-4.5			21.38 *	21.38 *	18.00 *	18.00 *	13.72 *	13.72 *					12.66 *	12.66 *	7.75

Option 5

Boom: 7700 mm - Arm: 4200 mm - W/O Bucket - Shoe: 900 mm - Counterweight: 11300 kg

Units: 1000 kg

A (m) \ B (m)	3		4.5		6		7.5		9		10.5		Max. lift		A (m)
9									13.06 *	13.06 *			9.79 *	9.79 *	9.80
7.5									13.24 *	13.24 *	10.74 *	10.74 *	9.45 *	9.45 *	10.64
6									13.90 *	13.79	12.95 *	10.62	9.36 *	9.36 *	11.22
4.5					20.81 *	20.81 *	17.07 *	17.07 *	14.83 *	13.28	13.38 *	10.35	9.47 *	8.75	11.57
3					23.77 *	23.25	18.75 *	16.73	15.81 *	12.75	13.89 *	10.05	9.79 *	8.40	11.72
1.5					25.84 *	21.99	20.10 *	15.95	16.62 *	12.27	14.24	9.76	10.34 *	8.31	11.67
0 (Ground)					26.67 *	21.26	20.82 *	15.42	17.06 *	11.91	14.01	9.56	11.18 *	8.47	11.43
-1.5			28.46 *	28.46 *	26.29 *	20.97	20.76 *	15.14	16.94 *	11.72	13.93	9.47	12.48 *	8.95	10.97
-3	25.99 *	25.99 *	31.78 *	31.78 *	24.77 *	21.00	19.76 *	15.10	15.97 *	11.71			12.88 *	9.86	10.28
-4.5	35.12 *	35.12 *	27.50 *	27.50 *	21.88 *	21.31	17.47 *	15.32	13.42 *	11.97			12.48 *	11.54	9.28
-6			21.02 *	21.02 *	16.92 *	16.92 *	12.68 *	12.68 *					11.28 *	11.28 *	7.88

Option 6

Boom: 6650 mm - Arm: 2900 mm - W/O Bucket - Shoe: 900 mm - Counterweight: 11300 kg

Units: 1000 kg

A (m) \ B (m)	3		4.5		6		7.5		9		Max. lift		A (m)		
7.5							17.77 *	17.77 *					14.78 *	14.78 *	8.02
6							18.34 *	18.34 *					14.51 *	14.22	8.77
4.5					23.43 *	23.43 *	19.57 *	17.82	17.41 *	13.40			14.74 *	12.87	9.22
3					26.05 *	23.82	20.90 *	17.14	17.88 *	13.08			15.43 *	12.22	9.41
1.5					27.69 *	22.86	21.83 *	16.58	18.13 *	12.79			16.69 *	12.11	9.35
0 (Ground)					27.86 *	22.36	21.93 *	16.24	17.62 *	12.64			17.49 *	12.57	9.04
-1.5			34.13 *	34.13 *	26.43 *	22.26	20.75 *	16.16					17.44 *	13.79	8.45
-3	36.04 *	36.04 *	29.20 *	29.20 *	22.96 *	22.53	17.01 *	16.48					16.88 *	16.42	7.52
-4.5			20.81 *	20.81 *	15.21 *	15.21 *							14.72 *	14.72 *	6.08

1. The nominal forces are based on the SAE J1097 standard.
2. The load point is the hook at the rear of the bucket.
3. * = The nominal loads are based on hydraulic capacity.
4. The nominal loads do not exceed 87% of the hydraulic capacity or 75% of the capacity of the swing.
5. For lifting capacity without bucket, simply add actual weight of the bucket from the values.
6. The configurations indicated do not necessarily reflect the standard equipment of the machine.

: Nominal force
 : Nominal force at the side or 360°

* Standard equipment

• Hydraulic system

- Boom and arm flow regeneration
- Swing anti-rebound valves
- Spare ports (valve)
- One-touch power boost
- Hydraulic piping for breaker

• Cab & Interior

- Sound-insulated and viscous support mounted cab
- Heated adjustable air suspension seat with adjustable headrest and armrest
- Air conditioning with climate control
- 7" (18 cm) LCD colour monitor panel
- Sliding front window, removable in two parts
- Ceiling light
- Intermittent windshield wiper
- Cigarette lighter and ashtray
- Cup holder
- Anti-theft protection
- Hot/cool box
- Fuel control dial
- AM/FM radio
- Remote radio on/off switch
- 12V spare power sockets
- Serial communication port for PC/laptop interface
- 2 hydraulic joysticks with 3 switches
- Speed regulator (auto-idle)
- Automatic rear window defrost
- 4 operating modes
- Control of auxiliary hydraulic flow
- Cab pack: sun visor, sun roof & rain shield

* Optional equipment

• Cab & Interior

- MP3/CD player
- Steel roof cover

• Safety

- Boom and arm cylinder safety valves
- Cab top/front guards (ISO 10262, FOGS standard)
- Overload warning device
- Large handrails and steps
- Punched metal anti-slip plates
- Seat belt
- Hydraulic safety lock lever
- Safety glass
- Hammer for emergency escape
- Right and left rear view mirrors
- Rear view camera
- Large cat walk
- Halogen work lights (2 front frame with guards, 4 cab-mounted, 4 boom-mounted and 1 rear side)
- Rotating beacon
- Reinforced cast steel pivot points

• Other

- DOOSAN DX700LC ISUZU engine combined with e-EPOS System
- Double element air cleaner
- Fuel filling pump
- Double fuel pre-filter with water separator sensor
- Dust screen for radiator/oil cooler
- Engine overheat prevention system
- Engine restart prevention system
- Self-diagnostic system
- Alternator (24V, 80 A)
- Electric horn
- Hydraulic track adjuster
- Track roller guards
- Greased and sealed track links
- Auto-grease system (swing and front)
- Hydraulic oil tank air breather filter
- Extra heavy-duty X-shaped undercarriage with integrated track spring and idler
- Well protected and optimised layout of hydraulic, electric & lubrication routing
- Boom: monobloc 7.70 m – arm: 2.90 m
- 650 mm double grouser shoes
- Counterweight 11300 kg
- Heavy-duty under cover
- Boom and bucket cylinder protection guards

• Other

- Hydraulic pipings for crusher, quick coupler, clamshell, tilting and rotating
- Additional filter for breaker piping
- 750 mm/900 mm double grouser shoe
- Boom: monobloc 6.65 m - arm: 2600 mm/3550 mm/4200 mm
- Buckets: GP 2.5, 3.0, 3.3, 3.9 & 4.5 m³ - HD 3.0, 3.3, 3.9 & 4.5 m³
- Fuel heater
- Lever pattern change
- Lower wiper
- Straight travelling priority system
- 1 additional hydraulic pump
- Telescopic beacon

Doosan Infracore

The pulse of transformation



Construction Equipment

Machine Tools

Forklift Trucks

Engines

The spirit of challenge and innovation has led Doosan. We started out as a small store in Seoul in 1896 and have expanded into a global company. Today we are engaged in the infrastructure support business (ISB), which encompasses industrial facilities, machinery, heavy equipment and construction. You can also encounter the Doosan brand in various other industries.

You are invited to take a closer look at the new world that is being built by Doosan, visit us at www.doosaninfracore.com



Doosan Infracore
Construction Equipment