

ATN

NEW

CX 12 / CX 15

Rough Terrain 4x4
Scissor lift



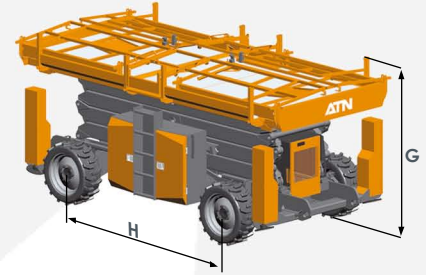
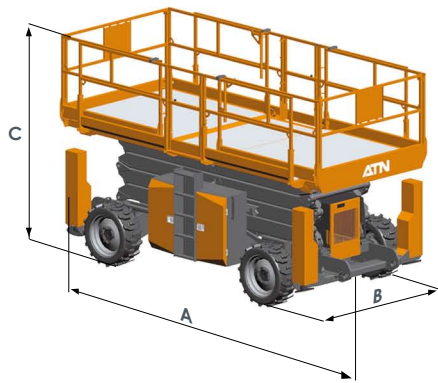

CX 12 / CX 15

ADVANTAGES

- Dual deck extensions.
- Hydraulic extension deployment (optional).
- Improved maintainability (on-board diagnostic system).
- Intuitive proportional controls.
- Automatic levelling outriggers.
- Permanent 4x4.
- Designed for intensive use.

STANDARD FEATURES

- 4 wheel drive.
- 2 Steered wheels.
- Levelling jack.
- On-board diagnostic system with colour LCD screen.
- Removable control unit.
- Load limiter.
- Tilt alarm.
- Hour meter.
- Non-slip aluminium platform floor.
- Oscillating axle.

OPTIONS

- Hydraulic extension deployment.
- AC power cable to platform.
- Air line to platform.
- Special paint colour(s).



This product complies with European regulations in force (EN 280). Due to our constant improvement policy, ATN reserves the right to make any modifications without any prior notice.



6, impasse ZI de Suriray n°2 - 47400 Tonneins - FRANCE
 Tél. : + 33 553 761 235 - Fax : + 33 553 880 107
 e-mail : contact@atnplatforms.com

	CX 12	CX 15
Working height	12,00 m (39 ft. 4 in.)	15,00 m (49 ft. 2 in.)
Platform height	10,00 m (32 ft. 8 in.)	13,00 m (42 ft. 7 in.)
Max lift capacity	1100 Kg (2425 lbs.)	700 kg (1543,2 lbs.)
Lift capacity on extension	230 Kg (507 lbs.)	200 kg (440,9 lbs.)
A Overall length	4,86 m (15 ft. 11 in.)	4,86 m (15 ft. 11 in.)
B Overall width	2,30 m (7 ft. 6 in.)	2,30 m (7 ft. 6 in.)
C Height with barrier in position	2,78 m (9 ft. 1 in.)	2,99 m (9 ft. 9 in.)
D Length with platform extensions	7,30 m (23 ft. 11 in.)	7,30 m (23 ft. 11 in.)
E Platform width	2,22 m (7 ft. 3 in.)	2,22 m (7 ft. 3 in.)
F Front and rear extension	2 x 1,25 m (2x4 ft. 1 in.)	2 x 1,25 m (2x4 ft. 1 in.)
G Height with barrier stowed	2,02 m (6 ft. 6 in.)	2,23 m (7 ft. 3 in.)
H Wheelbase	2,90 m (9 ft. 5 in.)	2,90 m (9 ft. 5 in.)
Ground clearance centre	0,36 m (1 ft. 2 in.)	0,36 m (1 ft. 2 in.)
Turning radius - inside	2,50 m (8 ft. 2 in.)	2,50 m (8 ft. 2 in.)
Turning radius - outside	5,60 m (18 ft. 4 in.)	5,60 m (18 ft. 4 in.)
Rough terrain special tyres	33 x 12 x 20	33 x 12 x 20

Raising / lower speed	50 / 50 s	50 / 50 s
Movement speed in stowed position	6 km/h (3,7 mph)	6 Km / h
Movement speed in up position	0,85 km/h (0,5 mph)	0,85 Km / h
Maximum tilt value	3°	2°
Gradeability	45 %	45 %
Max.ground bearing pressure on wheels	11,7 Kg/cm ²	11,7 Kg/cm ²
Max.ground bearing pressure on levelling jacks	7 Kg/cm ²	7 Kg/cm ²

Diesel engine KUBOTA V2203 48 CV	36 KW (48,3 hp.)	36 KW (48,3 hp.)
Fuel tank capacity	100 L (26,4 gal.)	100 L (26,4 gal.)
Hydraulic tank capacity	100 L (26,4 gal.)	100 L (26,4 gal.)
Total weight	6900 Kg (15211,8 lbs.)	7300 Kg (16093,7 lbs.)

