

# CS-563E CP-563E

Vibratory Soil  
Compactors



#### Cat® 3056E ATAAC Turbocharged Diesel Engine

Gross Power	112 kW	150 hp
Drum Width	2134 mm	84"

#### Operating Weight (with ROPS/FOPS cab)

CS-563E	11 450 kg	25,247 lb
CP-563E	11 880 kg	26,195 lb



## Productivity and Reliability in a Durable Package

*The CS-563E and CP-563E Soil Compactors offer high compaction performance, speed and gradeability to maximize productivity while providing exceptional reliability and durability.*

### Vibratory System

Pod-style eccentric weights ensure peak compaction performance and minimal service. High dynamic force helps achieve density in the fewest number of passes.

**Page 4**

### Engine

✓ *Cat 3056E ATAAC turbocharged electronic diesel engine delivers 112 kW (150 hp) and is built for performance and reliability without sacrificing fuel economy.*

**Page 5**

### Gradeability and Machine Control

The exclusive dual pump propel system provides a separate balanced hydraulic flow to both the rear drive axle and the front drum drive motor. This unique dual pump propel system provides excellent grade climbing, machine control and tractive power for effective use of the leveling blade option. Dual pumps also minimize drum and wheel spin-out in low traction conditions. High working speeds increases productivity.

**Page 6**

## Performance and reliability you can depend on.

*Based upon the industry-proven reputation of the Caterpillar® 500D-Series Soil Compactors, the new 500E-Series establishes new standards for productivity and reliability in the soil compaction industry.*

*Durable Cat powertrain, field-proven hydraulic and vibratory systems and the world's largest and most dedicated dealer support system ensure the 500E-Series Soil Compactors will provide maximum utilization.*

✓ *New feature*



---

### Visibility

- ✓ *The one-piece sloped hood design provides exceptional operator visibility to the outside edge of the rear tires and to the rear of the machine.*

**Page 6**

---

### Operator's Station

- The new 500E-Series Soil Compactors feature excellent operator comfort and visibility. A tilting steering column, propel lever wrist rest, grouped control gauges and conveniently located control switches enhance operator productivity and reduce fatigue. Four heavy-duty isolation mounts provide a smooth ride. Standard rearview mirrors, two front-facing and two rear-facing working
- ✓ *lights are provided. New steering wheel with integrated center horn function and steering knob helps reduce*
  - ✓ *operator fatigue. Machines with the open ROPS/FOPS platform are surrounded by handrails and features angled foot rests for sure footing when working on a grade.*

**Page 7**

---

### Versatility

Standard dual amplitude expands the compactor's application range. The large spread between high and low centrifugal force makes it easier to tailor the compactive effort to density specifications.

**Page 5**

The high traction propel system means the machine can go more places and push more material with the *optional foot-controlled leveling blade.*

The optional padfoot shell kit makes the CS-563E an extremely adaptable machine when compacting cohesive or semi-cohesive materials.

**Page 9**

---

### Serviceability

- ✓ *The newly designed one-piece fiberglass hood tilts forward to allow access to the engine and daily maintenance points.* Daily check points are accessible from ground level. Rear mounted cooling system allows easy
- ✓ *access for cleaning. The hydraulic oil cooler tilts down for convenient access*
- ✓ *and easier cleaning. Steps to the operator's platform swing-out for easier access to hydraulic components and oil filters.* The operator's platform tilts forward to provide convenient access to the hydraulic components. Vibratory bearing lube service interval of 3 year/3000 hour keeps maintenance to a minimum and maximizes production. The articulation hitch area features sealed-for-life bearings that never need maintenance.

**Page 10**



## Comfort and serviceability you deserve.

*The operator's station provides a comfortable and easy-to-use environment that promotes productive operation. Simplified service access and extended service intervals minimizes maintenance time and increases productive work time.*

## Vibratory System

*The pod-style vibratory system, proven reliable on 500D-Series Soil Compactors, delivers superior compactive force while offering serviceability advantages.*

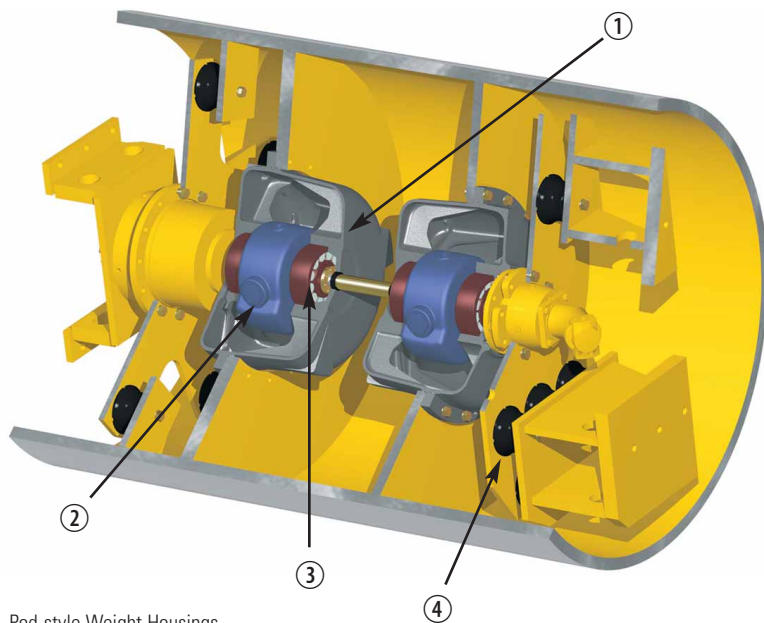

- 1 Pod-style Weight Housings
- 2 Patented Eccentric Weights
- 3 Heavy-duty Bearings
- 4 Isolation Mounts

**Pod-style weight housings** are assembled and sealed at the factory to ensure cleanliness, longer bearing life and easier field exchange or service.

**Dual amplitude** works efficiently in a wider range of applications. High or low amplitude is selected from the operator's station.

**Vibratory frequency** of 31.9 Hz (1914 vpm) for high compaction results. Optional variable frequency control available with a frequency range from 23.3 - 31.9 Hz (1400 - 1914 vpm) allows frequency to be better matched to varying job conditions.

**Large heavy-duty bearings** for the eccentric weight shaft designed for high compactive forces.

**3 year/3000 hour** vibratory bearing lube service interval for reduced maintenance.

**Improved isolation mounts** allow more force to be transmitted to the ground and less vibration to the drum yoke.

## Patented Eccentric Weights

*Reliable dual amplitude selection and innovative design ensure precise performance.*

High Amplitude

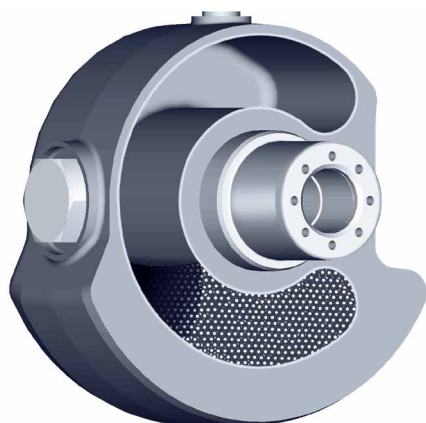

Low Amplitude

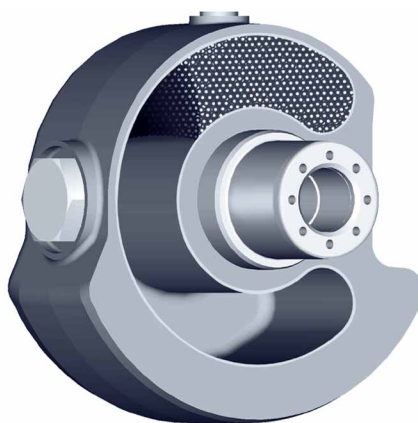

**Positive amplitude selection** is accomplished when the steel shot is repositioned inside the hollow eccentric weight. Direction of weight shaft rotation determines amplitude level.

**High reliability** since there is no chance of the high-strength spherical steel shot wedging together. System reliability is superior to swinging mechanical weights and is also quieter during starts and stops.

**Simplified control** from the operator's station with a selection switch on the operator's console.

**Longer service life** no heavy weights to slam together, no metal fragments to contaminate the bearing lubrication system.



# Caterpillar 3056E ATAAC Turbocharged Electronic Diesel Engine

*Industry-proven Caterpillar technology designed to provide unmatched performance, reliability and fuel economy with ample power for the most demanding jobs.*

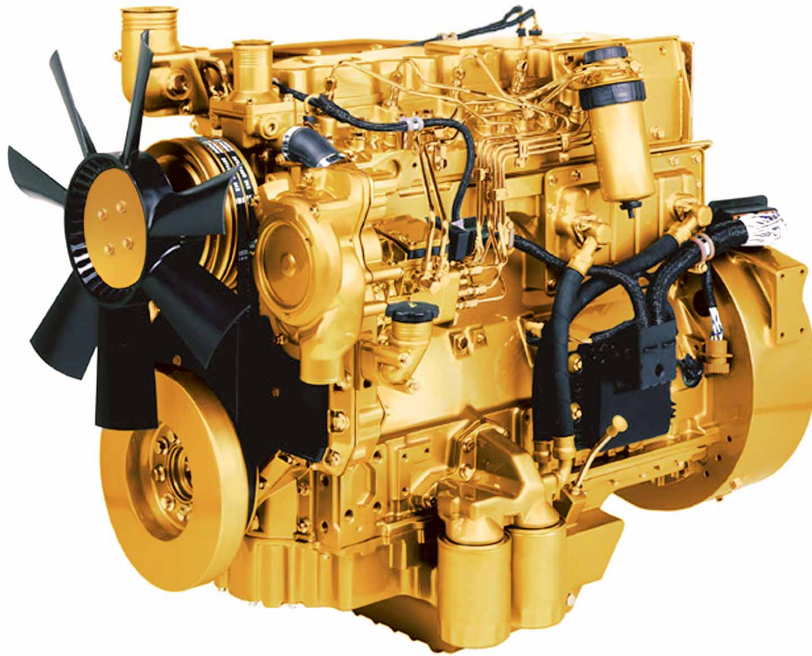

**Turbocharged air-to-air aftercooling** provides improved fuel economy by packing cooler, denser air into cylinders for more complete combustion of fuel and lower emissions.

**Electronic Control Module (ECM)** provides improved emissions and optimal performance through electronic timing and fuel delivery along with advanced troubleshooting and diagnostic capabilities using Electronic Technician (Cat ET).

**Highly-efficient combustion chamber** increases power while lowering fuel consumption, engine emissions and noise.

**High displacement-to-power ratio** ensures long life and provides outstanding reliability and durability.

**Large oil cooler** reduces oil deterioration and varnishing of internal components. Allows for 500 hour engine oil change intervals.

## Dual Pump Propel System

*Superior tractive effort and gradeability for outstanding productivity in demanding applications.*

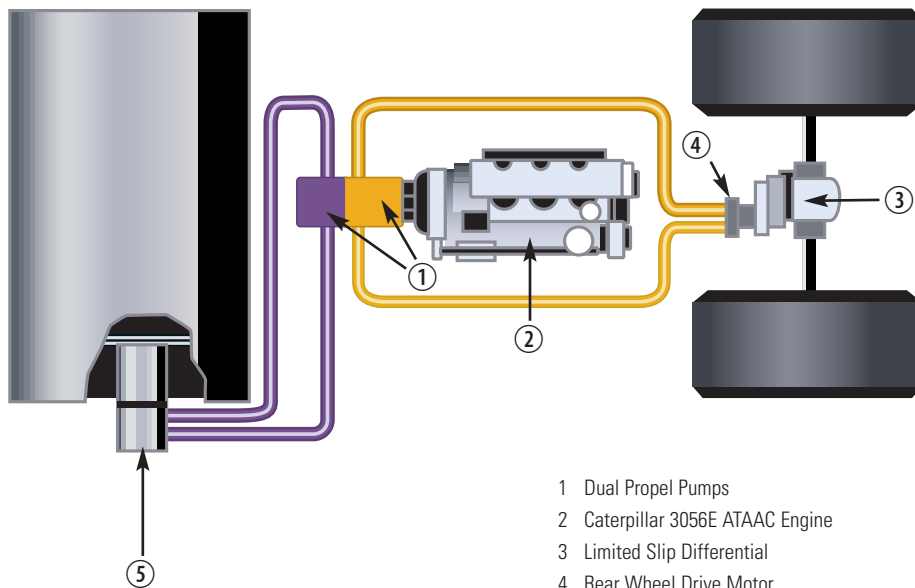

- 1 Dual Propel Pumps
- 2 Caterpillar 3056E ATAAC Engine
- 3 Limited Slip Differential
- 4 Rear Wheel Drive Motor
- 5 Drum Drive Motor

**Dual propel pumps** provide separate, balanced hydraulic flow to the rear wheel axle and the drum drive motors. Provides superior gradeability on steep slopes and increases tractive effort in loose or poor underfoot conditions.

**Limited slip differential** provides balanced tractive effort and smooth torque transfer to both rear wheels.

**Two speed ranges** for versatile operation. Low speed range for vibratory operation and maximum torque when climbing grades. High speed range moves machine quickly over longer distances.

**Flushing valves** in each propel circuit helps keep hydraulic oil cool and clean for maximum system efficiency.

## Gradeability and Machine Control

*The exclusive dual pump propel system, proven reliable on 500D-Series Soil Compactors, provides superior performance, machine control and exceptional grade climbing capability.*



**Two propel pump system** has dedicated pumps to drive the heavy-duty, high-torque rear wheel and drum motors independently. Should the drum or wheels begin to spin, there is always hydraulic flow to the non-spinning motor, allowing continuous tractive effort.

**Controllability is another feature of dual propel pumps.** The operator has complete machine control to stop, maintain machine position and change directions while on a slope. This feature is especially useful on steep slopes and loose underfoot conditions.

**The pressure override (POR) valve** limits maximum system pressure by de-stroking the propel pumps. This reduces pump flow while maintaining system pressure. This lowers the horsepower draw while accelerating the machine which saves fuel.

## One-Piece Sloped Hood Design

*The one-piece sloped fiberglass hood design provides excellent service access and exceptional operator visibility.*



**Visibility** to the tire edges and rear of machine is exceptional. The sloped hood allows the operator to see obstacles measuring 1 meter (3' 3") high located 1 meter (3' 3") to the rear of the machine. Excellent visibility increases productivity when working near obstructions or maneuvering around the job site.

**One-piece lockable engine hood** opens quickly and easily with the use of gas struts to provide unrestricted access to the engine, cooling system and all service points.

**Low sound levels** for the operator and the ground crew due to the one-piece engine hood and revised cooling air flow through the rear mounted radiator.



---

## Open Platform with ROPS/FOPS Canopy

*The platform is equipped with a ROPS/FOPS canopy and is enclosed by handrails and features angled foot rests for sure footing and support when working on a grade.*

---



**Spacious and comfortable working environment** with all controls, levers, switches and gauges positioned to maximize productivity.

**Unrestricted visibility** to the drum and tire edge and to the side and rear of the machine.

**The platform is enclosed by handrails** and features angled foot rests for sure footing and support when working on a grade.

**Standard equipment includes** two front-facing and two rear-facing working lights, handrails with angled foot rests, a lockable vandalism guard and a rear view mirror.

---

## Operator's Station

*Ergonomically designed for maximum operator productivity while offering excellent visibility and unmatched comfort.*

---

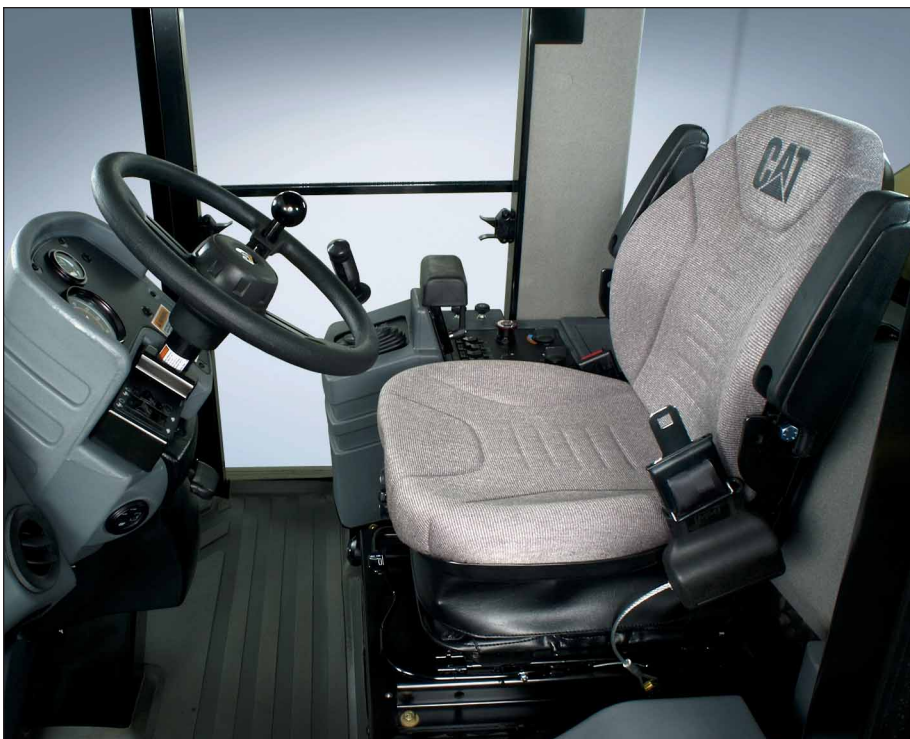

**Steering console and instrumentation gauges** are infinitely adjustable within the tilt range to the desired position of the operator. Entire console tilts for simple entrance and exit.

**Single lever control** for propel and vibratory On/Off provides simple and low effort operation. A padded adjustable wrist rest provides comfort.

**Comfortable and durable seat** has adjustable fore/aft position, bottom cushion height, suspension stiffness and flip-up arm rests with a 76 mm (3") wide retractable seat belt.

**Isolated operator's station** with four heavy-duty rubber mounts limits machine vibration transmitted to the operator's station.

**Rubber floor mat** provides sure footing and helps further isolate the operator from machine vibration and noise.

## ROPS/FOPS Cab

*Optional cab can increase machine utilization and provides greater year-round comfort in extreme environment conditions.*



**The cab is a spacious and comfortable work environment** that includes large windows, more interior room with storage areas, better ergonomics and good sound level reduction.

**Unrestricted visibility** to the drum and tire edge and to the side and rear of the machine.

**Items included with cab are:** two exterior rear view mirrors, two front-facing and two rear-facing working lights, cab lift cylinder, front and rear windshield wipers, slide-open side windows and climate control with heater and defroster.

**Optional air conditioning** further increases operator comfort.

## Padfoot Drum and Scrapers

*Padfoot drums provide superior performance when compacting clays. Heavy-duty scrapers break materials away from the drum surface to allow for deep penetration of the padfeet.*



**The padfoot drum has 140 pads** welded on the drum in a chevron arrangement.

**Each pad is 127 mm (5") high** and has a pad face surface area of 89.4 cm<sup>2</sup> (13.9 in<sup>2</sup>) to achieve high ground contact pressure for maximum compaction.

**The pads are involuted** to walk out of the lift without fluffing or “kicking up” the soil around the pads. Pads are tapered to help clean themselves.

**Heavy-duty scrapers** mounted on the front and rear of the drum are individually adjustable and replaceable. Helps to reduce excessive material build up between the pads.



## Leveling Blade

*Optional leveling blade increases machine versatility and utilization, plus greatly enhances productivity.*



**Expands machine versatility and utilization** for use in material knockdown, site leveling, trench backfilling and light dozing applications.

**Blade position** is controlled by operator's right foot to provide simple, one-handed operation of machine propel, steering and blade functions simultaneously for maximum productivity.

**Dual propel pumps provide plenty of power and tractive effort** for effective blade use without drum spin.

**Two-piece reversible and replaceable cutting edges** increase edge service life and reduce replacement costs.

**High mounting point** provides superior curb and obstruction clearance.

**No special permits for transporting** with a blade width of 2.5 m (8' 2").

## Padfoot Shell Kit

*Optional padfoot shell kit expands the application range of the CS-563E to work in either cohesive or semi-cohesive material.*

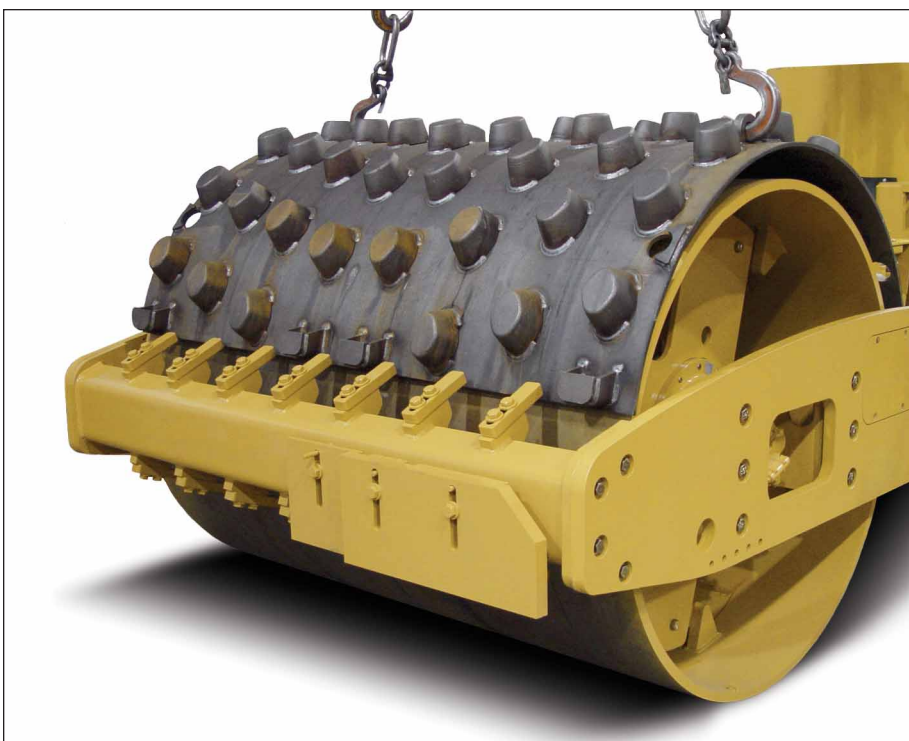

**Expands machine versatility and utilization** while providing a simple and cost-effective solution for jobs that may require both padfoot and smooth drum compaction.

**Dual-purpose bumper** is also included with the shell kit and does not need to be removed once installed. This bumper can also accept the optional leveling blade which increases machine versatility even further.

**Bumper also provides** adjustable scraper teeth for use with the padfoot shell kit and adjustable scraper plates for use with the standard smooth drum. When the scraper plates are not being used, they can be bolted onto the front of the bumper for convenient storage.

**Padfoot shell halves** can be quickly and easily installed or removed in about an hour with the use of an approved lifting device.

## Reliability and Serviceability

*The 500E-Series Soil Compactors continue to provide exceptional reliability and serviceability that you've come to expect from Caterpillar.*



*The one-piece fiberglass hood tilts forward for exceptional access to the engine and cooling system. Daily service points are accessible from ground level and are grouped on one side of the machine.*

**Visual indicators** allow easy check of engine coolant, hydraulic oil tank level and air filter restriction.

**Swing-out steps** allows easy access to hydraulic components and oil filters.

**Operator's station tilts forward** to allow convenient access to the hydraulic pumps.

**Rear mounted cooling system** provides easy access for cleaning. Hydraulic oil cooler tilts rearward for additional access to the radiator.

**Sealed-for-life bearings** in the articulation hitch never need to be greased.

**500 hour engine oil change interval.**

**3 year/3000 hour** vibratory bearing lube service interval for reduced maintenance.

**Quick connect hydraulic test ports** simplify system diagnostics.

**Ecology drains** provide an environmentally safer method to drain fluids. They are included on the radiator, engine oil pan, hydraulic and fuel tank.

**S•O•S<sup>SM</sup> (Scheduled Oil Sampling) ports** allow for simple fluid collection of engine and hydraulic oil.

**Secure hose routing** with polyethylene mounting blocks to reduce rubbing and increase service life.

**Nylon braided wrap and all-weather connectors** ensure electrical system integrity. Electrical wiring is color-coded, numbered and labeled with component identifiers to simplify troubleshooting.

**Maintenance-free Caterpillar batteries** are protected by bolt-on covers in the rear of the machine on both sides. Caterpillar batteries are specifically designed for maximum cranking power and protection against vibration.

**Machine is Product Link wire-ready.** The Caterpillar Product Link System (CPLS) ensures maximum uptime and minimum repair costs by simplifying tracking of equipment fleets. Provides automatic machine location and hour updates. Can be obtained through your local Caterpillar dealer.



## Drum and Vibratory System Specifications

Drum width	2134 mm	84"
Drum shell thickness		
CS-563E	30 mm	1.2"
CP-563E	25 mm	1"
Drum diameter		
CS-563E	1524 mm	60"
CP-563E	1295 mm	51"
Drum diameter (over pads) CP-563E	1549 mm	61"
Pads (CP-563E only)		
Number of pads	140	
Pad height	127 mm	5"
Pad face area	89.4 cm <sup>2</sup>	13.9 in <sup>2</sup>
Number of chevrons	14	
Eccentric weight drive	Hydrostatic	

### Weight at Drum (with ROPS/FOPS canopy)

CS-563E	5840 kg	12,877 lb
CP-563E	6075 kg	13,395 lb

### Static Linear Load\*

CS-563E	27.4 kg/cm	153.3 lb/in
---------	------------	-------------

\*Meets NFP 98736 class: VM2

### Frequency

Standard	31.9 Hz	1914 vpm
Optional	23.3 - 31.9 Hz	1400 - 1914 vpm

### Nominal Amplitude

High	1.7 mm	0.067"
Low	0.85 mm	0.033"

### Centrifugal Force @ 31.9 Hz (1914 vpm)

Maximum	266 kN	60,000 lb
Minimum	133 kN	30,000 lb

## Engine

Four-stroke cycle, six cylinder Caterpillar 3056E ATAAC electronic turbocharged low emissions diesel engine. Certified to meet the current model year emissions regulations under the provisions of 40 CFR 89.112 Tier 2 and 97/68/EC Stage 2.

Ratings at	RPM	kW	hp
Gross power	2200	112	150

Ratings of Caterpillar machine engines are based on standard air conditions of 25°C (77°F) and 100 kPa (29.61" Hg) dry barometer. Power is based on using 35° API gravity fuel having an LHV of 42 780 kJ/kg (18,390 Btu/lb) when used at 30°C (86°F) [ref. a fuel density of 838.9 g/L (7.001 lb/U.S. gal)]. Net power advertised is the power available at the flywheel when the engine is equipped with fan, air cleaner, muffler and alternator.

No derating required up to 3000 m (9900') altitude.

The following ratings apply at 2200 RPM when tested under the specified standard conditions:

Net Power	kW	hp
EEC80/1269	107	143
ISO 9249	107	143
SAE J1349	106	142

### Dimensions

Bore	100 mm	3.94"
Stroke	127 mm	5"
Displacement	5.98 liters	365 cu. in.

Dual-element, dry-type air cleaner with visual restriction indicator, thermal starting aid and fuel/water separator are standard.

## Transmission

Two variable displacement piston pumps supply pressurized flow to two dual displacement piston motors. One pump and motor drives the drum propel system while the other pump and motor drives the rear wheels. The dual pump system ensures equal flow to the drive motors regardless of the operating conditions. In case the drum or wheels lose traction, the other motor can still build additional pressure to provide added torque.

The drive motors have two swashplate positions allowing operation at either maximum torque for compaction and gradeability or greater speed for moving around the job site. A rocker switch at the operator's console triggers an electric over hydraulic control to change speed ranges.

### Speeds (forward and reverse):

CS-563E	
Low Range	5.7 km/h – 3.5 mph
High Range	11.4 km/h – 7.0 mph
CP-563E	
Low Range	5.8 km/h – 3.6 mph
High Range	11.6 km/h – 7.2 mph

## Final Drives and Axle

Final drive is hydrostatic with gear reducer to the drum and hydrostatic with differential and planetary gear reduction to each wheel.

### Axle:

Heavy-duty fixed rear axle with a limited slip differential for smooth and quiet torque transfer.

### Tires:

CS-563E: 587 mm (23.1") x 660 mm (26") 8-ply flotation  
 CP-563E: 587 mm (23.1") x 660 mm (26") 8-ply traction

## Operator and Machine Protective Equipment

**Roll Over Protective Structure/Falling Object Protective Structure (ROPS/FOPS)** canopy is a two-post structure that bolts directly onto flanges welded to the operator platform. The structure meets SAE J1040 May94, SAE J231 Jan81, ISO 3449-1992 and ISO 3471-1994. This structure may be an option in some areas and standard in others. Consult your dealer for specifics.

**Backup Alarm** — 107 dB(A) alarm sounds whenever the machine is in reverse.

**Forward Warning Horn** — located on the front of machine to alert ground personnel.

**Seat Belt** — 76 mm (3") wide seat belt is standard.

## Instrumentation

Electronic Control Module (ECM) constantly monitors condition of the engine. Alerts the operator if a problem does occur with three levels of warning. Warning system includes: Action Alarm and Lamp, Low Engine Oil Pressure, High Engine Coolant Temperature, High Hydraulic Oil Temperature, Low Charge Pressure, Starting Aid and High Combustion Air Temperature. Instrumentation also includes an Alternator Malfunction Light, Check Engine/Electrical Fault, Service Hour Meter and Fuel Gauge.

## Total Customer Support System

**Service capability** — most dedicated dealer support system to ensure fast service whether at the dealer's shop or in the field by trained technicians using the latest tools and technology.

**Parts availability** — most parts on dealer's shelf when you need them. Computer-controlled, emergency search system backup.

**Parts stock lists** — dealer helps you plan on-site parts stock to minimize your parts investment while maximizing machine availability.

**Literature support** — easy-to-use parts books, operation and maintenance manuals and service manuals to help you get maximum value from your Caterpillar equipment.

## Electrical

The 24-volt electrical system consists of two maintenance-free Cat batteries, electrical wiring is color-coded, numbered, wrapped in vinyl-coated nylon braid and labeled with component identifiers. The starting system provides 750 cold cranking amps (cca). The system includes a 55-amp alternator.

## Service Refill Capacities

	Liters	Gallons
Fuel tank	300	79
Total capacity	330	87
Cooling system	26	6.9
Engine oil w/filter	12.1	3.2
Eccentric weight housings	26	6.9
Axle & final drives	18	4.8
Hydraulic tank	64	16.9
Filtration system (pressure type)		
Propel	15 micron absolute	
Vibratory	15 micron absolute	

## Frame

Fabricated from heavy gauge steel plate and rolled sections and joined to the drum yoke at the articulation pivot. Articulation area is structurally reinforced and joined by hardened steel pins. One vertical pin provides a steering angle of  $\pm 34^\circ$  and a horizontal pin allows frame oscillation of  $\pm 15^\circ$ . Safety lock prevents machine articulation when placed in the locked position. Sealed-for-life hitch bearings never need maintenance. Frame also includes tie-down points for transport.

## Brakes

### Service brake features

- Closed-loop hydrostatic drive system provides dynamic braking during operation.

### Secondary brake features\*

- Spring-applied/hydraulically-released multiple disc type brake mounted on the drum drive gear reducer. Secondary brakes are activated by: a button on the operator's console; loss of hydraulic pressure in the brake circuit; or when the engine is shut down. A brake interlock system helps prevent driving through the secondary brake.

*\*Braking system meets SAE J1472 and EN500.*

## Steering

A priority-demand hydraulic power-assist steering system provides smooth low-effort steering. The system always receives the power it needs regardless of other hydraulic functions.

### Minimum turning radius:

Inside	3.68 m (12' 1")
Outside	5.81 m (19' 1")

### Steering angle:

(each direction)  $\pm 34^\circ$

### Oscillation angle:

(each direction)  $\pm 15^\circ$

### Hydraulic system:

Two 76 mm (3") bore, double-acting cylinders powered by a gear-type pump.

**Remanufactured parts** — pumps and motors, pod-style weight housings, engines, fuel system and charging system components available from dealer at a fraction of new part cost.

**Machine management services** — effective preventive maintenance programs, cost-effective repair options, customer meetings, operator and mechanic training.

**Flexible financing** — your dealer can arrange attractive financing on the entire line of Caterpillar equipment. Terms structured to meet cash flow requirements. See how easy it is to own, lease or rent Cat equipment.



## Dimensions

	CS-563E		CP-563E	
A Overall length	5.76 m	(18' 11")	5.76 m	(18' 11")
B Length with blade	6.3 m	(20' 8")	6.3 m	(20' 8")
C Overall width	2.29 m	(7' 6")	2.29 m	(7' 6")
D Drum width	2.13 m	(7')	2.13 m	(7')
E Width with blade	2.5 m	(8' 2")	2.5 m	(8' 2")
F Blade height	680 mm	(27")	680 mm	(27")
G Blade cutting depth	127 mm	(5")	120 mm	(4.7")
H Drum shell thickness	30 mm	(1.2")	25 mm	(1")
I Drum diameter	1524 mm	(60")	1295 mm	(51")
Drum diameter over pads	—	—	1549 mm	(61")
J Height at ROPS/FOPS canopy	3.06 m	(10' 1")	3.07 m	(10' 1")
K Height at ROPS/FOPS cab	3.07 m	(10' 1")	3.07 m	(10' 1")
L Wheelbase	2.90 m	(9' 6")	2.90 m	(9' 6")
M Ground clearance	448 mm	(17.6")	456 mm	(18")
N Curb clearance	497 mm	(19.6")	505 mm	(19.9")
Inside turning radius	3.68 m	(12' 1")	3.68 m	(12' 1")
Outside turning radius	5.81 m	(19' 1")	5.81 m	(19' 1")

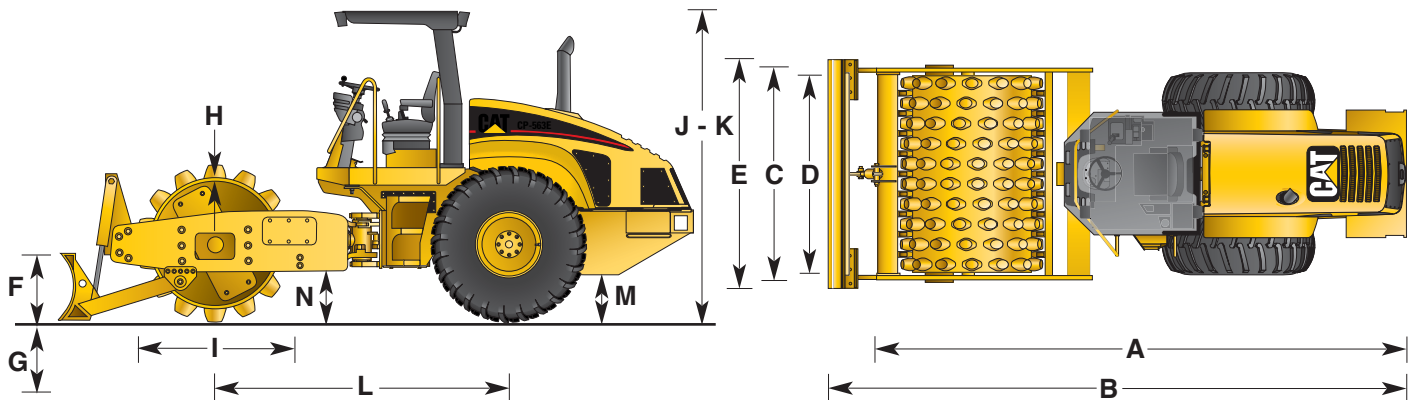

## Operating Weights

Weights shown are approximate and include lubricants, coolant, full fuel and hydraulic tanks and a 80 kg (175 lb) operator.

Machine Weights	CS-563E		CP-563E	
with open platform	10 900 kg	24,035 lb	11 335 kg	24,994 lb
with ROPS/FOPS canopy	11 120 kg	24,520 lb	11 555 kg	25,479 lb
equipped with leveling blade	11 770 kg	25,953 lb	12 200 kg	26,901 lb
equipped with padfoot shell kit	12 780 kg	28,180 lb	—	—
equipped with blade and shell kit	13 420 kg	29,591 lb	—	—
with ROPS/FOPS cab	11 450 kg	25,247 lb	11 880 kg	26,195 lb

Weight at Drum	CS-563E		CP-563E	
with open platform	5780 kg	12,745 lb	6020 kg	13,274 lb
with ROPS/FOPS canopy	5840 kg	12,877 lb	6075 kg	13,395 lb
equipped with leveling blade	6735 kg	14,851 lb	6970 kg	15,369 lb
equipped with padfoot shell kit	7475 kg	16,482 lb	—	—
equipped with blade and shell kit	8360 kg	18,434 lb	—	—
with ROPS/FOPS cab	5925 kg	13,065 lb	6160 kg	13,583 lb

# CS-563E and CP-563E Specifications

Operating Weights (with ROPS/FOPS)	CS-563E		CP-563E	
Machine	11 120 kg	24,520 lb	11 555 kg	25,479 lb
at drum	5840 kg	12,877 lb	6075 kg	13,395 lb
Static linear load (at drum)	27.4 kg/cm	153.3 lb/in	—	—

## Machine Dimensions

Overall length	5.76 m	(18' 11")	5.76 m	(18' 11")
Overall width	2.29 m	(7' 6")	2.29 m	(7' 6")
Overall height at ROPS/FOPS canopy	3.06 m	(10' 1")	3.07 m	(10' 1")
Wheelbase	2.90 m	(9' 6")	2.90 m	(9' 6")
Ground clearance	448 mm	(17.6")	456 mm	(18")
Curb clearance	497 mm	(19.6")	505 mm	(19.9")
Inside turning radius	3.68 m	(12' 1")	3.68 m	(12' 1")

## Drum Dimensions

Drum width	2.13 m	(7')	2.13 m	(7')
Drum shell thickness	30 mm	(1.2")	25 mm	(1")
Drum diameter	1524 mm	(60")	1295 mm	(51")
Drum diameter over pads	—	—	1549 mm	(61")
Number of pads	—	—	140	
Pad height	—	—	127 mm	(5")
Pad face area	—	—	89.4 cm <sup>2</sup>	13.9 in <sup>2</sup>

## Vibratory System

Frequency				
Standard	31.9 Hz	1914 vpm	31.9 Hz	1914 vpm
Optional	23.3 - 31.9 Hz	1400 - 1914 vpm	23.3 - 31.9 Hz	1400 - 1914 vpm
Nominal amplitude				
High	1.7 mm	0.067"	1.7 mm	0.067"
Low	0.85 mm	0.033"	0.85 mm	0.033"
High (with padfoot shell kit)	1.2 mm	0.047"	—	—
Low (with padfoot shell kit)	0.6 mm	0.024"	—	—
Centrifugal force @ 31.9 Hz (1914 vpm)				
Maximum	266 kN	60,000 lb	266 kN	60,000 lb
Minimum	133 kN	30,000 lb	133 kN	30,000 lb
Maximum (with padfoot shell kit)	266 kN	60,000 lb	—	—
Minimum (with padfoot shell kit)	133 kN	30,000 lb	—	—

## Power Train

Engine	3056E		3056E	
Gross power	112 kW	150 hp	112 kW	150 hp
Speeds				
High range	11.4 km/h	7.0 mph	11.6 km/h	7.2 mph
Low range	5.7 km/h	3.5 mph	5.8 km/h	3.6 mph
Axle (differential)	Limited Slip		Limited Slip	
Tire size	587 x 660 mm	(23.1 x 26")	587 x 660 mm	(23.1 x 26")

## Miscellaneous

Electrical system	24 VDC		24 VDC	
Articulation angle	± 34°		± 34°	
Oscillation angle	± 15°		± 15°	
Fuel capacity	330 liters	87 gal	330 liters	87 gal

## Optional Equipment

- ROPS/FOPS Cab
- Air Conditioning
- Roll-Down Sun Screen
- Sun Visor
- Cab Rear View Mirrors
- Rotating Beacon
- Vibratory Gauge
- Variable Frequency
- Transmission Guard
- Polyurethane Drum Scrapers
- Padfoot Shell Kit
- Leveling Blade
- Smooth Drum Rear Steel Scraper
- Operator Platform Lift Cylinder
- Compaction Indicator



## Estimated Production

### CS-563E and CP-563E

- Based on depth of fill below final grade (surface)
- Based on final compacted thickness of layer
- Density spec. is based on Standard Proctor Test

Depth	Density Spec.	15 cm (6 in) Layer	30 cm (12 in) Layer
<b>Surface</b> 0 - 0.5 m (0 - 2 ft)	> 98%	190 m <sup>3</sup> /hr (250 yd <sup>3</sup> /hr)	380 m <sup>3</sup> /hr (500 yd <sup>3</sup> /hr)
<b>Shallow</b> 0.5 - 3 m (2 - 10 ft)	95 - 98%	345 m <sup>3</sup> /hr (450 yd <sup>3</sup> /hr)	610 m <sup>3</sup> /hr (800 yd <sup>3</sup> /hr)
<b>Deep</b> > 3 m (> 10 ft)	90 - 95%	610 m <sup>3</sup> /hr (800 yd <sup>3</sup> /hr)	1150 m <sup>3</sup> /hr (1500 yd <sup>3</sup> /hr)

## Productivity Comparisons

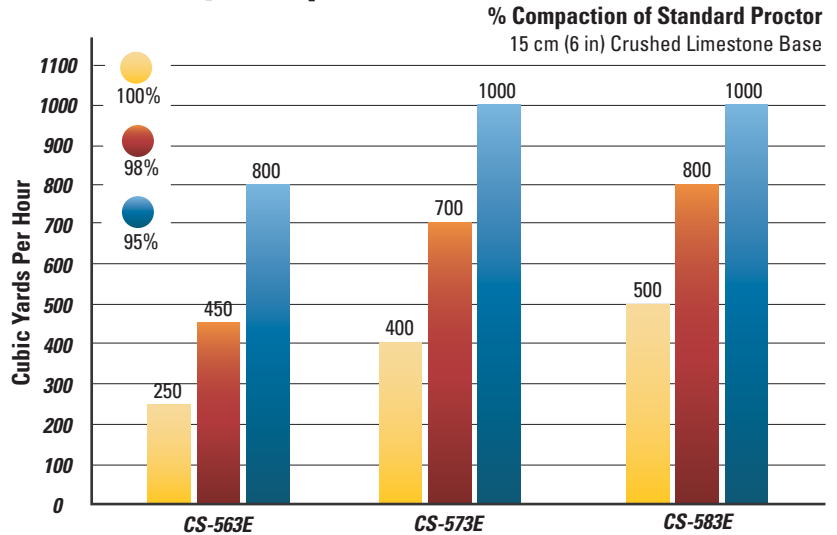

Note: Results are similar for padfoot drums. Results may vary for different applications.

## Machine Selection

Key: ○ = Good   ◐ = Better   ● = Best

Application	Layer Thickness	Smooth Drum			Padfoot Drum		
		CS-563E	CS-573E	CS-583E	CP-563E	CP-573E	CP-583E
Sand, Clayey or Silty Sand, Mine Tailing	15 - 30 cm (6 - 12 in)	●	◐	○	○	○	○
	30 - 45 cm (12 - 18 in)	◐	●	◐	○	○	◐
	45 - 60 cm (18 - 24 in)	○	◐	●	○	◐	◐
Clay, Sandy or Silty Clay, Stabilized Clay	15 - 30 cm (6 - 12 in)	◐	◐	◐	●	◐	○
	30 - 45 cm (12 - 18 in)	○	◐	◐	◐	●	◐
	45 - 60 cm (18 - 24 in)	○	○	◐	○	◐	●
Silt, Sandy or Clayey Silt, Coal, Ash, Solid Waste	15 - 30 cm (6 - 12 in)	◐	◐	○	●	◐	◐
	30 - 45 cm (12 - 18 in)	◐	○	○	◐	◐	○
	45 - 60 cm (18 - 24 in)	○	○	—	◐	○	○
Base Aggregate, Gravel, Crushed Rock, Stabilized Base	15 - 30 cm (6 - 12 in)	◐	◐	●	○	○	○
	30 - 45 cm (12 - 18 in)	○	◐	◐	○	○	◐
	45 - 60 cm (18 - 24 in)	—	○	○	○	◐	◐
<b>Gradeability</b>		●	◐	○	●	◐	○

## Shell Kit Performance

Key: ○ = Good   ● = Best

	Padfoot Drum	Shell Kit	Shell Kit Performance	Performance Ranking	
No. of Pads	140	120	<b>Less Kneading</b> <i>better for silt</i>		
Pad Height	127 mm (5 in)	90 mm (3.5 in)	<b>Less Penetration</b> <i>better for silt and sandy clay</i>		
Weight at Drum	6075 kg (13,395 lb)	7475 kg (16,482 lb)	<b>Higher Ground Pressure</b> <i>better for sandy clay</i>		
Max. Amplitude	1.7 mm (0.067 in)	1.2 mm (0.047 in)	<b>Smaller Drum Movement</b> <i>better for silt and clay</i>		
				Padfoot Drum	Shell Kit
				Heavy Clay	●   ○
				Sandy Clay	○   ●
				Silt with Clay	○   ●
				Slopes/Trenches	●   ○
				Thick Layers	●   ○

# Caterpillar offers a comprehensive line of vibratory soil compactors.

The CS/CP-573E and CS/CP-583E are the most productive, reliable and versatile vibratory soil compactors in their class which will consistently yield high quality compaction results.

Contact your local Caterpillar dealer to learn more about the complete line of Caterpillar Paving Products.



## CS-573E and CP-573E

Designed for high compaction performance in tough applications. Beneficial where common fill lift thickness is greater than 30 cm (12"), or where density requirements exceed 95% of standard Proctor.

### Operating Weight (with ROPS/FOPS)

CS-573E	13 570 kg	29,922 lb
CP-573E	13 750 kg	30,319 lb
Drum Width	2.13 m	7'
Frequency	31.9 Hz	1914 vpm
Nominal Amplitude		
High	1.7 mm	0.067"
Low	0.85 mm	0.033"
Centrifugal Force		
Maximum	266 kN	60,000 lb
Minimum	133 kN	30,000 lb
Gross Power	112 kW	150 hp



## CS-583E and CP-583E

Designed for high compaction performance in highly demanding applications. Beneficial where common fill lift thickness is greater than 45 cm (18"), or where density requirements exceed 98% of standard Proctor.

### Operating weight (with ROPS/FOPS)

CS-583E	15 100 kg	33,296 lb
CP-583E	15 235 kg	33,593 lb
Drum Width	2.13 m	7'
Frequency	30 Hz	1800 vpm
Nominal Amplitude		
High	1.8 mm	0.071"
Low	0.9 mm	0.035"
Centrifugal Force		
Maximum	332 kN	74,600 lb
Minimum	166 kN	37,300 lb
Gross Power	112 kW	150 hp



- The CS-323C and CP-323C have a gross power rating of 52 kW (70 hp) and a drum width of 1270 mm (50"). Operating weights range from 4.5 - 5.0 metric ton (5.0 - 5.5 U.S. ton).\*
- The CS-423E has a gross power rating of 60 kW (80 hp) and a drum width of 1676 mm (66"). Operating weight ranges from 6.6 - 7.9 metric ton (7.3 - 8.7 U.S. ton).\*
- The CS-433E and CP-433E have a gross power rating of 75 kW (100 hp) and a drum width of 1676 mm (66"). Operating weights range from 6.6 - 8.5 metric ton (7.3 - 9.4 U.S. ton).\*
- The CS-663E, CP-663E and CS-683E have a gross power rating of 129 kW (173 hp) and a drum width of 2134 mm (84"). Operating weights range from 16.5 - 19.4 metric ton (18.1 - 21.4 U.S. ton).\*

\*Dependent on machine configuration and optional attachments.

© 2003 Caterpillar  
www.CAT.com

QEHQ9943 (1/03)

Featured machines in photography may include optional equipment.  
Materials and specifications are subject to change without notice.

# CATERPILLAR®