

Engine	Cummins 6LTAA8.9-C240
Gross Power	179 kW (243 hp) @ 2,200 rpm
Net Power	161 kW (219 hp) @ 2,200 rpm
Operating Weight	19,500 kg
Standard Bucket Size	3.5 m <sup>3</sup>
Standard Breakout Force	195 kN
Standard Dump Clearance	3,100 mm

# 862H WHEEL LOADER



TOUGH WORLD. TOUGH EQUIPMENT.

# 862H SPECIFICATIONS >>>

## ENGINE

Emission Regulation	Tier 2 / Stage II
Make	Cummins
Model	6LTAA8.9-C240
Gross Power	179 kW (243 hp) @ 2,200 rpm
Net Power	161 kW (219 hp) @ 2,200 rpm
Peak Torque	1124 N·m
Displacement	8.9 L
Number of Cylinder	6
Aspiration	Turbocharged & Air-to-air intercooled

## TRANSMISSION

Transmission Type	Countershaft, power shift
Torque Converter	Single stage, three elements
Maximum Travel Speed, fwd	38 km/h
Maximum Travel Speed, rev	27 km/h
Number of Speed, fwd	4
Number of Speed, Rev	3

## AXLES

Differential Front Type	Limited slip
Differential Rear Type	Limited slip
Axle Oscillation	±12°

## STEERING

Steering Configuration	Articulated
Steering Relief Pressure	20 MPa

## BRAKES

Service Brake Type	Wet discs brake
Service Brake Actuation	Hydraulic
Parking Brake Type	Manual electronic control
Parking Brake Actuation	Hydraulic

## HYDRAULIC SYSTEM

Main Pump Type	Gear + Piston
Main Relief Pressure	22 MPa
Raise	5.7 s
Dump Time	1.3 s
Float Down Time	3 s
Fastest Total Cycle Time	10 s

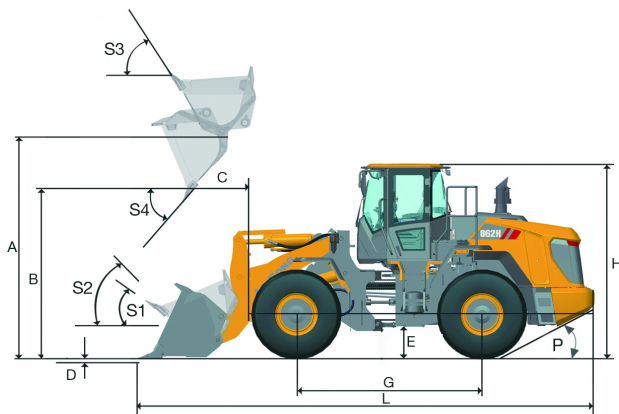

## LOADER ARM PERFORMANCE

Tipping Load - Straight	16,600 kg
Tipping Load - Full Turn	14,100 kg
Bucket Breakout Force	195 kN
A Maximum Hinge Pin Height	4,212 mm
B Dump Clearance at Full Height Discharge	3,100 mm
C Dump Reach at Full Height Discharge	1,195 mm
D Maximum Digging Depth, Bucket Level	80 mm
S <sub>1</sub> Rollback at Ground Level	43°
S <sub>2</sub> Bucket Rollback at Carry	48°
S <sub>3</sub> Bucket Rollback at Maximum Height	63°
S <sub>4</sub> Maximum Dump Angle at Full Height	45°

## BUCKET PERFORMANCE

Reference Bucket	3.0-6.5 m <sup>3</sup>
------------------	------------------------

## DIMENSIONS

E Ground Clearance	431 mm
G Wheelbase	3,450 mm
H Cab Height	3,467 mm
J Wheel Tread	2,280 mm
K Width Over Tires	2,880 mm
L Length with Bucket Down	8,628 mm
M Turn Angle, Either Side	38°
P Rear Angle of Departure	27°
R <sub>1</sub> Turning Radius, Bucket Carry	7,114 mm
R <sub>2</sub> Turning Radius, Outside of Tire	6,450 mm

## TIRES

Tire Size	23.5 - 25
-----------	-----------

## OPERATING WEIGHTS

Operating Weight	19,500 kg
------------------	-----------

## SERVICE CAPACITY

Fuel Tank	330 L
Engine Oil	22 L
Cooling System	52 L
Hydraulic System	280 L
Transmission and Torque Converter	35 L
Axles, Each	41 L

