

Engine	Perkins 1204F-E44TAN
Max Gross Power	98 kW (131 hp) @ 2,200 rpm
Max Net Power	93 kW (125 hp) @ 2,200 rpm
Operating Weight	10,860 kg
Standard Bucket Size	1.9 m <sup>3</sup>
Standard Breakout Force	90 kN
Standard Dump Clearance	2,800 mm

# 835H

WHEEL LOADER



TOUGH WORLD. TOUGH EQUIPMENT.

# 835H SPECIFICATIONS >>>

## ENGINE

Emission Regulation	Tier 4 Final / Stage IV
Make	Perkins
Model	1204F -E44TAN
Max Gross Power	98 kW (131 hp) @ 2,200 rpm
Max Net Power	93 kW (125 hp) @ 2,200 rpm
Peak Torque	530 N · m @ 1,400 rpm
Displacement	4.4 L
Number of Cylinders	4
Aspiration	Turbocharged & Air-to-air intercooled

## TRANSMISSION

Transmission Type	Countershaft, power shift
Torque Converter	Single stage, three elements
Maximum Travel Speed, fwd	38.6 km/h
Maximum Travel Speed, rev	25.1 km/h
Number of Speeds, fwd	4
Number of Speeds, rev	3

## AXLES

Differential Front Type	Limited slip
Differential Rear Type	Conventional
Axle Oscillation	±11°

## STEERING

Steering Configuration	Articulated
Steering Relief Pressure	18 Mpa

## BRAKES

Service Brake Type	Wet discs brake
Service Brake Actuation	Hydraulic
Parking Brake Type	Manual electronic control
Parking Brake Actuation	Hydraulic

## HYDRAULIC SYSTEM

Main Pump Type	Piston
Main Relief Pressure	19 MPa
Raise	5.5 sec
Dump Time	1.2 sec
Float Down Time	3 sec
Fastest Total Cycle Time	9.7 sec

## LOADER ARM PERFORMANCE

Tipping Load - Straight	9,452 kg
Tipping Load - Full Turn	7,369 kg
Bucket Breakout Force	90 kN
A Maximum Hinge Pin Height	3,720 mm
B Dump Clearance at Full Height Discharge	2,800 mm
C Dump Reach at Full Height Discharge	1,076 mm
D Maximum Digging Depth, Bucket Level	80 mm
S <sub>1</sub> Bucket Rollback at Ground Level	45°
S <sub>2</sub> Bucket Rollback at Carry	48°
S <sub>3</sub> Bucket Rollback at Maximum Height	60°
S <sub>4</sub> Maximum Dump Angle at Full Height	45°

## BUCKET PERFORMANCE

Reference Bucket	1.5-3.0 m <sup>3</sup>
------------------	------------------------

## DIMENSIONS

E Ground Clearance	325 mm
G Wheelbase	2,870 mm
H Cab Height	3,200 mm
J Wheel Tread	1,855 mm
K Width Over Tires	2,300 mm
L Length with Bucket Down	7,115 mm
M Turn Angle, Either Side	38°
P Rear Angle of Departure	28°
R <sub>1</sub> Turning Radius, Bucket Carry	6,520 mm
R <sub>2</sub> Turning Radius, Outside of Tire	5,410 mm

## TIRES

Tire Size	17.5 - 25
-----------	-----------

## OPERATING WEIGHTS

Operating Weight	10,860 kg
------------------	-----------

## SERVICE CAPACITY

Fuel Tank	190 L
Engine Oil	12 L
Cooling System	22 L
Hydraulic Reservoir	120 L
Transmission and Torque Converter	40 L
Front Axle	34 L
Rear Axle	34 L
DEF Tank	19 L

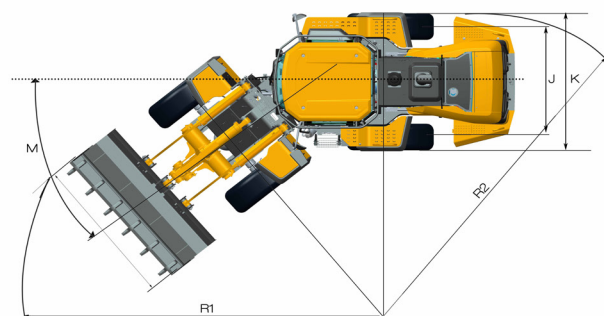
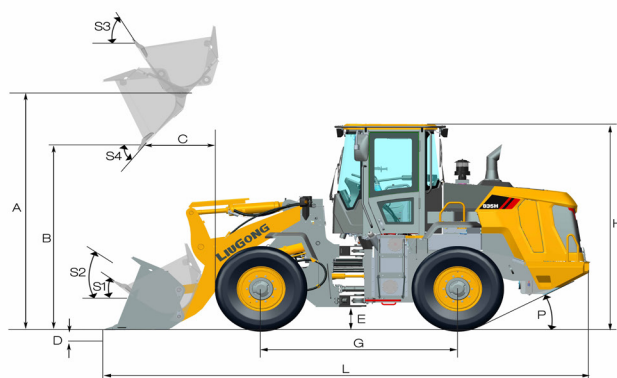

Guangxi Liugong Machinery Co., Ltd.

No. 1 Liutai Road, Liuzhou, Guangxi 545007, PR China  
 T: +86 772 3886124 E: overseas@liugong.com  
 www.liugong.com

Specifications and designs are subject to change without notice. Machines shown may include optional equipment.

06/2017 Designed by LiuGong