



Volvo Construction Equipment

ECR25D

Volvo Compact Excavators 2.49-2.96 t / 5,490-6,526 lb 20.9 hp



Small size. Big power.

The ECR25D has been designed with mobility and performance in mind. Featuring a range of innovations engineered for effortless transportation, you'll benefit from an ideal transport weight and an integrated bucket transport system. This powerful, short radius excavator boasts strong lifting capabilities as well as breakout and tear out forces that rival larger machines.

Maintenance made easy

It's easy to keep your hardworking ECR25D up and running with worry-free maintenance. The wide-opening lockable engine hood provides clear access to all daily service points, while the minimum 50-hour interval on all greasing points saves valuable time and money. Check hydraulic oil at a glance with the Volvo patented hydraulic filter, featuring transparent housing to prevent unplanned downtime.



Control costs

Decrease your total cost of ownership with a range of built-in features. The ideally matched Volvo engine and single variable displacement pump reduce fuel consumption, while auto-idle and auto-engine shutdown maximizes fuel efficiency, cut service costs and ensure high resale value. Controlling your costs needn't be complicated, which is why the flat glass windows of the cab can be replaced easily and inexpensively.



The operator's choice

As the industry's leading operator environment, the easily accessible Volvo cab boasts superb visibility, comfortable seat, ergonomic controls, and conveniently-located cup and phone holders. The flat floor makes cleaning quick and easy, while noise and vibration insulation keep the operator fresh and focused - longer.



Intuitive operation

Experience precise, smooth and effortless command of the boom offset and auxiliary hydraulic flows with proportional fingertip controls. The easy-to-use joystick allows you to fine-tune the maximum hydraulic flow of any attachment to ensure ideal speed and power for any task. And, with automatic two-speed travel, you can drive the machine at high speed, which is automatically reduced when more traction is required.





MADE FOR MOBILITY

Conveniently transport this highly mobile machine with up to three buckets and a hydraulic breaker on a small trailer and benefit from a total transport weight of less than 3.5 tonnes. Safe transportation is enabled by four, easily accessible, tie-down points.



BUILT READY

Get the most out of your hardworking ECR25D with Volvo's range of durably-designed attachments. Purpose-built to work in harmony with your machine, Volvo attachments optimize versatility and uptime of your ECR25D, enabling you to effectively perform a variety of jobs.

All work, all the time

Built to work for you, the ECR25D is an industry-leader. Optimize machine performance, productivity and versatility with Volvo's range of durable attachments and Customer Solutions, tailored to your business and operations. Just like your ECR25D, our unique, global dealer support network is built around you. Protect your profits with a long-term partnership and benefit from an array of services using Genuine Volvo Parts, delivered by passionate people.

Fast, safe change outs

Change attachments quickly and efficiently with the pin-grabber mechanical quick coupler from Volvo. Compatible with the wide range of Genuine Volvo attachments, Volvo couplers ensure the optimum versatility for any task you choose.



Unlock your potential

Unlock the full potential of your operation with the ECR25D, compatible with any attachment, installed safely and easily thanks to built-in relief valves. And, with the secondary accessory circuit, you have the potential to do even more. Contact your local dealer and benefit from leading expertise and advanced attachment solutions.



Volvo - a partner to trust

Being a Volvo customer means having a complete set of services at your fingertips. Your dealer is here for you and your machine anytime, anywhere – offering professional expertise, financial packages and Customer Support Agreements, catered specifically to help you achieve your business objectives.



Keep your Volvo a Volvo

We're committed to providing a complete solution to guarantee the highest performance of your Volvo machine, including high quality Genuine Volvo Parts, extensively tested and approved because every part is vital for performance. Rely on our leading parts availability to ensure maximum uptime, extend the life of your Volvo and optimize the profitability of your business.



Up to the challenge

Auto-idle

Engine speed is reduced to idle when controls are inactive for more than five seconds, cutting fuel consumption and noise.

Control costs

Decrease your total cost of ownership with a range of built-in features, which reduce fuel consumption, cut service costs and ensure high resale value.

BUILT READY

The ECR25D is a perfect match with Volvo attachments for increased versatility, performance and profitability.

Auto engine shutdown

The engine shuts off when inactive for a pre-set amount of time, minimizing operating costs and ensuring a high resale value.

50-hour greasing intervals

Excellent stability and outstanding hydraulics ensure the machines are capable of lifting heavy loads.

Automatic travel speed

Continually drive the machine at high speed. When more traction is needed, the speed is automatically reduced.



The operator's choice

Ergonomic, spacious and safe, the Volvo cab features all around visibility, intuitive controls and built-in comfort.

Patented hydraulic filter

Filtration occurs when the tank is filled and before oil returns via the drain lines. The transparent bowl makes checking for oil contamination easy.

MADE FOR MOBILITY

Conveniently transport the highly mobile ECR25D with up to three buckets and a hydraulic breaker on a small trailer.

Ultimate lifting capacity

Excellent stability and outstanding hydraulics ensure the machines are capable of lifting heavy loads.

Maintenance made easy

Daily service points are grouped under the engine hood and are easily accessible for straightforward maintenance.

Intuitive operation

Use ergonomic fingertip controls for precise, smooth and effortless command of the boom offset and auxiliary hydraulics.

Volvo - a partner to trust

We offer the right solutions throughout the entire life cycle of your Volvo to help you achieve your business objectives.



Volvo ECR25D in detail

Engine		
Engine		D1.1A
Max. power at	r/min (r/s)	2 400 (40)
Gross	kW (hp)	15.6 (20.9)
According to ISO 9249 / SAE J1995		
Max. torque	Nm (ft lbf)	71.4 (52.7)
at engine speed	r/min	1 600
No. of cylinders		3
Displacement	cm³ (in³)	1.12 (0.07)
Bore	mm (in)	78 (3.07)
Stroke	mm (in)	78.4 (3.09)
Compression ratio		24
Electrical system		
Voltage	V	12
Battery	V	1 x 12
Battery capacity	Ah	70
Alternator	V/Ah	12/40
Hydraulic system		
Pump type		Variable displacement, load sensing
Maximum system flow	l/min (gal/min)	58 (15.3)
Maximum flow for accessories	l/min (gal/min)	50 (13.2)
Maximum pressure for accessories	MPa (psi)	25 (3 626)
Maximum flow for 2nd accessory circuit (option)	l/min (gal/min)	23 (6.1)
Maximum operating pressure	MPa (psi)	25 (3 626)
Digging Performances		
Standard bucket width (blade, W/O side cutter)	mm (in)	500 (19.7)
Standard bucket mass	kg (lb)	59 (130)
Standard bucket rated capacity	l (ft³)	74 (2.61)
Bucket rotation	°	205
Bucket breakout force (ISO)	daN (lbf)	2 233 (5 020)
Short arm tearout force (ISO)	daN (lbf)	1 776 (3 993)
With short arm	mm (ft in)	1 050 (3'5")
Long arm tearout force (ISO)	daN (lbf)	1 497 (3 365)
With long arm	mm (ft in)	1 350 (4'5")
Swing system		
Max. slew speed	r/min	9.4
Max. slew torque	daNm (ft lbf)	485 (3 577)

Undercarriage		
Rubber track width	mm (in)	250 (9.8)
Steel track width	mm (in)	300 (11.8)
Bottom/top rollers per side		3 / 1
Track tension		by grease piston
Blade (width x height)	mm (in)	1 550 x 312 (61 x 12.3)
Travel System		
Max. drawbar pull	daN (lbf)	1 984 (4 460)
Max. travel speed low	km/h (mi/h)	2.4 (1.5)
Max. travel speed high	km/h (mi/h)	4.5 (2.8)
Gradeability	°	30
Service Refill		
Fuel tank	l (gal)	28 (7.4)
Hydraulic system, total	l (gal)	33 (8.7)
Hydraulic tank	l (gal)	23 (6.1)
Engine oil	l (gal)	5.1 (1.35)
Engine coolant	l (gal)	4 (1.06)
Travel reduction unit	l (gal)	2 x 0.6 (2 x 0.159)
Sound Level		
Interior sound level according to ISO 6396		
LpA	dB(A)	78
External sound level according to ISO 6395 and EU Noise Directive (2000/14/EC) and 474-1:2006 +A1:200		
LwA	dB(A)	93
Weight and Ground Pressure		
Operating weight according to ISO 6016	kg (lb)	2 490 (5 490)
Ground pressure (cab)	kPa (psi)	30.5 (4.42)
Ground pressure (canopy)	kPa (psi)	29.4 (4.26)
Transport weight	kg (lb)	2 412 (5,318)
With heated cab		
With direct-fit bucket		
With rubber tracks	mm (in)	250 (9.8)
With short arm	mm (in)	1 050 (41.3)
With fuel tank capacity	%	100
With canopy	-kg (-lb)	90 (198.4)
With extra counterweight	+kg (+lb)	100 (220.5)
With long arm and additional counterweight	+kg (+lb)	112 (246.9)
With steel tracks	+kg (+lb)	163 (359.3)
Steel tracks	mm (in)	300 (11.8)
With rubber tracks	+kg (+lb)	78 (172)
Rubber tracks	mm (in)	300 (11.8)

LIFTING CAPACITY ECR25D

These capacities are given for a machine equipped with a cabin, 250 mm (9.8 in) rubber tracks and without a bucket or quick-coupler.

The below values are in compliance with ISO standard 10567.

They do not exceed 75% of the tipping load or 87% of the hydraulic limit with the machine on firm level ground.

Loads marked with an asterisk (*) are limited by machine's

hydraulic lifting capacity rather than tipping load.

Caution: In accordance with standard EN 474-5,

the machine must be equipped to carry out handling operations.

It is the operator's obligation to know and follow the applicable national and local safety regulations.

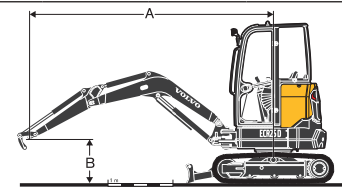

	Lifting point height (B) m (ft in)		Lifting point radius (A)									
			2.0 m (6.5 ft)			3.0 m (9.8 ft)			Max reach			Max. m (ft in)
			Along undercarriage, dozer blade up	Along undercarriage, dozer blade down	Across undercarriage	Along undercarriage, dozer blade up	Along undercarriage, dozer blade down	Across undercarriage	Along undercarriage, dozer blade up	Along undercarriage, dozer blade down	Across undercarriage	
Arm: 1 050 mm (3'5")	3 (9'10")	kg (lb)	-	-	-	436 (961)	566* (1,247*)	418 (921)	424 (934)	577* (1,272*)	406 (895)	3.05 (10'0")
	2 (6'7")	kg (lb)	-	-	-	430 (947)	599* (1,320*)	412 (908)	310 (683)	601* (1,324*)	298 (656)	3.67 (12'0")
Counterweight: standard	1 (3'3")	kg (lb)	-	-	-	406 (895)	795* (1,752*)	389 (857)	280 (617)	642* (1,415*)	269 (593)	3.86 (12'8")
	0 (0'0")	kg (lb)	712 (1,569)	1 602* (3,531*)	670 (1,477)	390 (859)	933* (2,056*)	373 (822)	291 (641)	699* (1,541*)	280 (617)	3.71 (12'2")
	-1 (-3'-3")	kg (lb)	722 (1,591)	1 543* (3,401*)	680 (1,499)	393 (866)	849* (1,871*)	375 (826)	369 (813)	771* (1,699*)	354 (780)	3.15 (10'4")
Arm: 1 050 mm (3'5")	3 (9'10")	kg (lb)	-	-	-	474 (1,044)	566* (1,247*)	452 (996)	461 (1,016)	577* (1,272*)	439 (967)	3.05 (10'0")
	2 (6'7")	kg (lb)	-	-	-	467 (1,029)	599* (1,320*)	445 (981)	339 (747)	601* (1,324*)	324 (714)	3.67 (12'0")
Counterweight: +100 kg (220 lb) additional	1 (3'3")	kg (lb)	-	-	-	443 (976)	795* (1,752*)	422 (930)	307 (676)	642* (1,415*)	293 (645)	3.86 (12'8")
	0 (0'0")	kg (lb)	778 (1,715)	1 602* (3,531*)	729 (1,607)	427 (941)	933* (2,056*)	406 (895)	320 (705)	699* (1,541*)	305 (672)	3.71 (12'2")
	-1 (-3'-3")	kg (lb)	789 (1,739)	1 543* (3,401*)	739 (1,629)	430 (947)	849* (1,871*)	409 (901)	404 (890)	771* (1,699*)	385 (848)	3.15 (10'4")
Arm: 1 350 mm (4'5")	2 (6'7")	kg (lb)	-	-	-	465 (1,025)	500* (1,102*)	445 (981)	294 (648)	532* (1,172*)	282 (621)	3.98 (13'0")
	1 (3'3")	kg (lb)	808 (1,781)	1 334* (2,940*)	760 (1,675)	439 (967)	715* (1,576*)	418 (921)	269 (593)	571* (1,258*)	258 (568)	4.15 (13'7")
Counterweight: +100 kg (220 lb) additional	0 (0'0")	kg (lb)	760 (1,675)	1 608* (3,545*)	713 (1,571)	417 (919)	897* (1,977*)	397 (875)	278 (612)	623* (1,373*)	266 (586)	4.01 (13'2")
	-1 (-3'-3")	kg (lb)	763 (1,682)	1 659* (3,657*)	716 (1,578)	413 (910)	902* (1,988*)	393 (866)	335 (738)	692* (1,525*)	320 (705)	3.51 (11'6")

Specifications

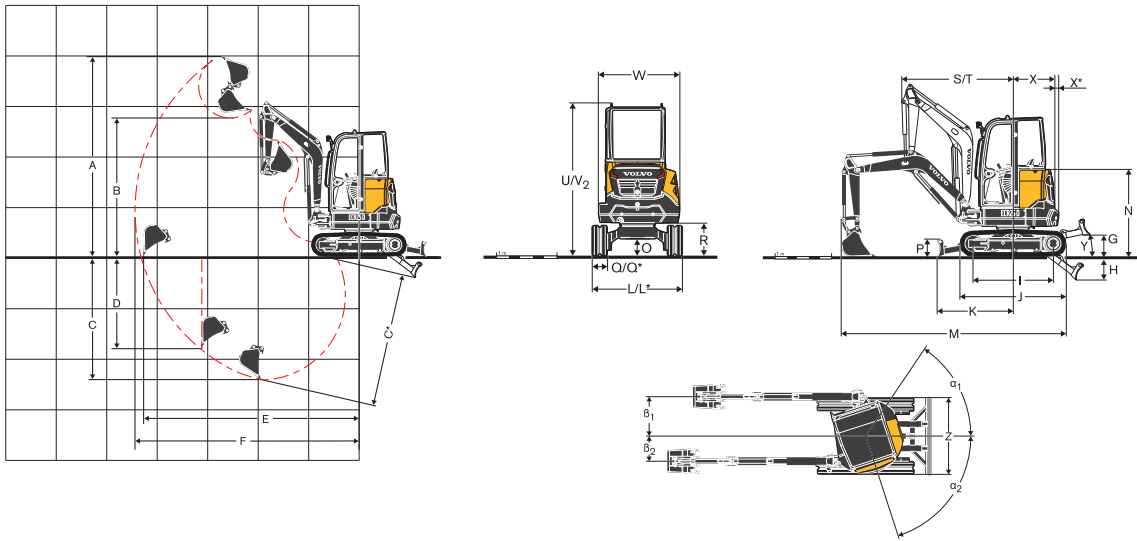

DIMENSIONS

Description		Unit	ECR25D	
			1 050 (3'5")	1 350 (4'5.1")
Arm		mm (ft in)		
A	Maximum cutting height	mm (ft in)	4 010 (13'2")	4 183 (13'9")
B	Maximum dump height	mm (ft in)	2 784 (9'2")	2 957 (9'8")
B*	Maximum bucket clearance	mm (ft in)	2 897 (9'6")	3 070 (10'1")
C	Digging depth	mm (ft in)	2 461 (8'1")	2 761 (9'1")
C*	Maximum digging depth	mm (ft in)	2 672 (8'9")	2 965 (9'9")
D	Maximum vertical wall digging depth	mm (ft in)	1 832 (6'0")	2 119 (6'11")
E	Maximum digging reach at ground level	mm (ft in)	4 313 (14'2")	4 602 (15'1")
F	Maximum digging reach	mm (ft in)	4 484 (14'9")	4 768 (15'8")
G	Highest position dozer blade	mm (ft in)	401 (1'3.7")	
H	Lowest position dozer blade	mm (ft in)	422 (1'4.6")	
I	Tumbler length	mm (ft in)	1 440 (4'8.6")	
J	Track length	mm (ft in)	1 906 (6'3")	
K	Dozer blade, maximum reach at ground level	mm (ft in)	1 365 (4'5.7")	
L	Overall width with 250mm (9.8") rubber tracks	mm (ft in)	1 500 (4'11")	
L1	Overall width with 300mm (11.8") rubber tracks	mm (ft in)	1 550 (5'1")	
M	Overall length	mm (ft in)	4 008 (13'2")	3 876 (12'9")
M*	Transport length	mm (ft in)	4 595 (15'1")	4 525 (14'10")
N	Overall height of engine hood	mm (ft in)	1 570 (5'1.8")	
O	Minimum ground clearance	mm (ft in)	290 (0'11.4")	
P	Dozer blade height	mm (ft in)	312 (1'0.2")	
Q	Shoe width (rubber)	mm (ft in)	250 (0'9.8")	
Q1		mm (ft in)	300 (0'11.8")	
R	Ground clearance to superstructure	mm (ft in)	554 (1'9.8")	
S	Front slew radius	mm (ft in)	2 002 (6'7")	
T	Front slew radius with maximum offset	mm (ft in)	1 555 (5'1")	
U	Overall height cab	mm (ft in)	2 535 (8'4")	
U*	Overall height canopy	mm (ft in)	2 505 (8'3")	
W	Overall width of superstructure	mm (ft in)	1 340 (4'5")	
X	Tail slew radius	mm (ft in)	750 (2'6")	825 (2'8")
X1	Additional counterweight overhang	mm (ft in)	75 (0'3")	(incl.)
Y	Angle of approach	°	34	
Z	Dozer blade width	mm (ft in)	1 550 (5'1")	
α1	Maximum boom swing angle to the left	°	72	
β1	Maximum boom offset to the right	mm (ft in)	784 (2'7")	
α2	Maximum boom swing angle to the right	°	56	
β2	Maximum boom offset to the left	mm (ft in)	496 (1'8")	

1: Option

Equipment

STANDARD EQUIPMENT

Engine

Low emission, water-cooled, Volvo 3-cylinder diesel engine, meeting EPA Tier 4 environmental regulations.
 Engine restart prevention system. Starter motor is protected against ignition when engine is already running.
 Dry-type single element air filter.
 Plastic fuel tank with drain plug.
 Protective strainer on the fuel suction pipe inside the tank.
 Water separator.
 Translucent fuel filter.

Drivetrain

Axial piston hydraulic motors equipped with an epicyclic reduction gears.
 Automatic two speed travel.
 Bottom flanged rollers lubricated for life.
 Grease tensioning wheel lubricated for life.

Electric / Electronic control system

Maintenance free battery.
 IP67 protected electrical system and high quality connectors.
 Protected battery cut-off switch.
 In-cab 12V power socket.

Swing system

Radial piston hydraulic motor with direct engagement on the ball internal crown wheel (no reduction gears).
 Integrated shockless valve.
 Automatic multi-disc spring applied hydraulic released slew brake.
 Centralized and remote lubrication of crown wheel & ball bearing.

Undercarriage

"X" shape, box welded fabricated frame with sloping side members.
 2 Tie-down points on the dozer blade.
 2 Tie-down points on the frame
 2 lifting points on the frame.
 Sturdy removeable protecting covers for track motors and slew system.
 400HB weld-on edge on dozer blade.

Hydraulic system

Plastic tank with drain plug.
 Variable displacement, load-sensing piston pump.
 Closed centre flow-sharing main control valve.
 Cushioning on cylinders:
 Boom up
 Large tiltable oil cooler.
 Patented filtering and filling element.
 Double-acting hydraulic circuit for accessories.

Canopy

Certified FOPS level 1 on top (Falling Objects Protective Structure).
 Certified TOPS (Tip-Over Protective Structure).
 Certified ROPS (Roll-Over Protective Structure).
 Cushioned operator station.
 Large and roomy uncluttered floor.
 Left hand-rail access.
 Seat-belt with warning indicator.
 Right rear-view mirror.
 One working light on the top front.
 Toolbox with integrated storage for operator's manual and lockeable door.
 Phone holder.

STANDARD EQUIPMENT

Cab

Certified FOPS level 1 on top (Falling Object Protective Structure).
 Certified TOPS (Tip-Over Protective Structure).
 Certified ROPS (Roll-Over Protective Structure).
 Cushioned operator station.
 Large door access.
 Large and roomy uncluttered floor.
 Gas-strut assisted front window opening.
 Full opening front bay with in-cab storage for the front lower window.
 Front windscreen wiper and washer nozzle.
 Right hand side sliding window.
 Flat toughened glass.
 Heating systems with in-cab adjustment of temperature and air flow level.
 Multiple adjustable air vents.
 Filtered air inlet.
 Toolbox with integrated storage for operator's manual and lockeable door.
 Cab inside light.
 Seat-belt with warning indicator.
 Right rear-view mirror.
 Two working lights on top front.
 Cup holder.
 Phone holder.
 Provision for a radio (antena and electric wiring already fitted)

Digging equipment

Monobloc box welded fabricated boom.
 Boom cylinder rod protection.
 Integrated lifting point on the boom.
 Monobloc box welded arms with casted ends.
 Long-life steel bushings.
 Hardened, pre-lubricated and corrosion resistant pins.
 50 hours greasing intervals.

Machine controls

Finger tip control for boom offset.
 Finger tip control for auxiliary circuit.
 Breaker toggle switch on right joystick.
 Automatic locking device for pilot controls and travel levers when the left console is raised.
 Engine starting safety device: the left console must be raised to operate the starter.
 Pressure accumulator to lower the equipment on the ground when the engine is switched off.
 High torque / automatic two speed change over switch on the dashboard.
 High speed toggle switch on the dozer blade lever.
 Large travel pedals.

Instrumentation and monitoring

Permanent digital hour meter.
 Water temperature and fuel level gauges.
 Warning lights for hydraulic filter and air filter restriction.
 Self-acting emergency engine shutdown. Prevents failures in case of coolant overheating or too low engine oil pressure.
 Several warning lights, coupled to an audible signal, in the event of malfunction (overheating, drop in oil pressure, low battery voltage...)

Official approval

Machine conforming to European directive 2006/42/EC.
 Noise emissions in the environment conforming to directive 2000/14/EC.
 Hand Arm Vibrations - Whole Body Vibrations compliant with directive 2002/44/EC.
 Electromagnetic compatibility (EMC) conforming to European directive 2004/108/EC and its amendments.
 Object handling device conforming to EN 474-1 and EN 474-5 standards.
 FOPS on top level 1 conforming to ISO 10262 standard.
 TOPS conforming to ISO 12117 and EN 13531 standards.
 ROPS conforming to ISO 3471-1 and / SAE J1040 standards.
 OPG 1 conforming to ISO 10262 standard (when equipped).
 OPG 2 conforming to ISO 10262 standard (when equipped).

OPTIONAL EQUIPMENT
Engine
Engine auto idling
Engine auto shut-down with time adjustment
Dual stage air filter
Operator environment
Canopy
Cab with heater
Vinyl or textile seat, low backrest and standard seat belt
Vinyl or textile seat, lumbar adjustment, high backrest and retractable seat belt
High visibility 2" orange seatbelt
3" or 75mm black retractable seat belt
High visibility orange entrance foot step
Additional lockable storage box (behind the seat)
ISO / SAE control pattern change
Travel alarm
Radio, AUX, USB, Bluetooth
Anti-theft, code lock
Anti-theft, coded key
Machine exterior
Left rearview mirror
Protected worklight on the boom
Rear worklight
Rotating beacon, halogen
Warning beacon, flashing LED
Halogen worklights
LED worklights
Additional counterweight
Front canopy guard (OPG1)
Severe-duty guards for cab or canopy (OPG2, front & top)
Several level of paint customisation (RAL specifications) to match with your corporate identity
Undercarriage
250 mm / 9.8" rubber tracks
300 mm / 11.8" rubber tracks
300 mm / 11.8" steel tracks

OPTIONAL EQUIPMENT
Hydraulic system
Proportional finger tip control for boom offset and accessories
On / Off finger tip control for boom offset and accessories
Accessory flow adjustment
Hammer / shear valve
Hydraulic drain for accessories
Breaker and clamshell auxiliaries
Second accessory circuit
Flat face hydraulic quick couplings
Single acting circuit for hydraulic quick couplers
Double acting circuit for hydraulic quick couplers
Boom & arm safety lifting valves with overload indicator
Boom, arm and dozer blade safety lifting valves with overload indicator
Safety valve certification
Mineral hydraulic oil VG46
Bio hydraulic oil VG46 (PANOLIN®)
Mineral hydraulic oil VG68
Mineral hydraulic oil VG32
Bio hydraulic oil VG32 (PANOLIN®)
Digging equipment
Short arm 1 200 mm / 3' 11.2"
Long arm 1 500 mm / 4' 11"
Service and maintenance
Tool kit
Attachments
Volvo quick coupler mechanical (pin-on)
Extra pin kit
Lehnhoff® Quick Coupler Mechanical (MS03)
S-type hydraulic quick coupler (S40)
General purpose buckets (250 mm or 10" / 34 L or 0.04 yd3 up to 750 mm or 29" / 119 L or 0.15 yd3)
Aggressive cut buckets (350 mm / 50 L or 550mm / 95 L)
Fix ditching buckets (1 200 mm or 47" 125 L or 0.16 yd3 or 1 300 mm or 51" 141 L or 0.18 yd3)
Tilttable ditching buckets (1 200 mm or 47" 125 L or 0.16 yd3)
Hydraulic breaker HB03LN
Hydraulic breaker HB200PLUS
Telematics
Care Track

SELECTION OF VOLVO OPTIONAL EQUIPMENT

Specific colours



Anti-theft key



Safety valve (boom, arm and blade)



Secondary accessory circuit



LED lights beacon



Not all products are available in all markets. Under our policy of continuous improvement, we reserve the right to change specifications and design without prior notice. The illustrations do not necessarily show the standard version of the machine.

VOLVO

Volvo Construction Equipment

www.volvoce.com