

# PERFORMANCE DATA

FEEDER (TIER 4)

BMF 2500

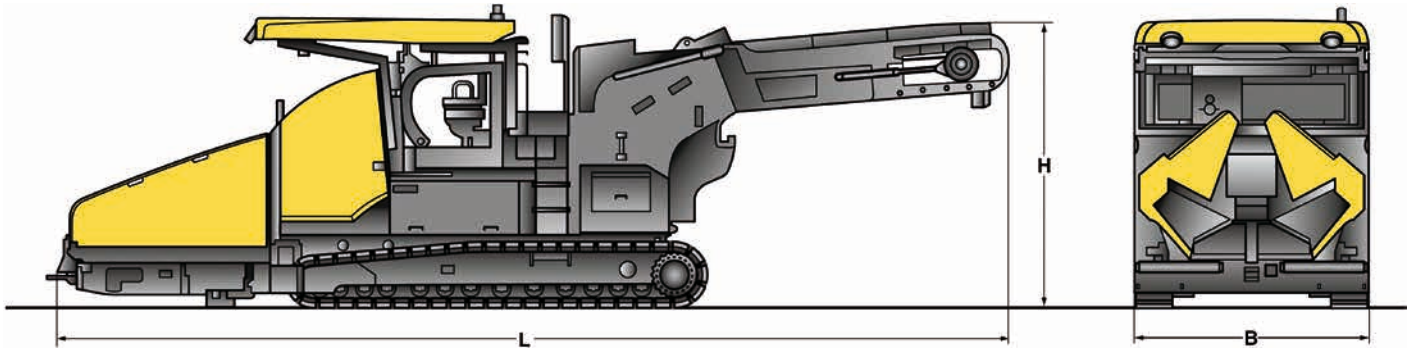



**Dimensions in m**

	<b>Length</b>	<b>Width</b>	<b>Height</b>
<b>BMF 2500 S</b>	9,20	2,55	3,10
<b>BMF 2500 M</b>	10,26	2,55	3,10
<b>BMF 2500 S Offset</b>	14,30	2,55	3,10



Work reliably – the chain-reinforced conveyor belt prevents downtime.



Flexible in use – the optionally available swivel wheel for the BMF 2500 S.



Counteract demixing – a width of 1.20 m ensures gentle material transport.



Everything in sight – the optional lift platform provides the best overview.

## Technical Data

## BOMAG BMF 2500

### WeightsCECE

BMF 2500 S .....	kg	20000
BMF 2500 SM .....	kg	20500
BMF 2500 S Offset .....	kg	24500

### Dimensions

Transport length BMF 2500 S .....	mm	9200
length BMF 2500 M .....	mm	10260
length BMF 2500 S Offset .....	mm	14300
Transport width .....	mm	2550
Transport height .....	mm	3100
Loading angle.....	°	10

### Travel characteristics

Travel speed .....	km/h	0-4
Working speed .....	m/min	0-25 variable

### Drive

Engine manufacturer .....	Cummins
Type .....	QSB6.7-C260 (Tier 4 final)
Emission stage .....	Stage IV / TIER 4
Exhaust classification.....	Tier 4 final
Cooling .....	Fluid
Number of cylinders.....	6
Displacement.....	cm <sup>3</sup> 6700
Rated power.....	kW / hp 170 / 231
Power .....	rpm 2200

### Track chains

Overall length .....	mm	3900
Width .....	mm	320

### Hopper

Capacity .....	m <sup>3</sup> / t	7 / 15
Width (wings open).....	mm	3345
Width (wings closed).....	mm	2550
Length .....	mm	2200
Filling height (middle) .....	mm	523

### Conveyor belt

Type .....	Rubber band, mounted on two roller chains, with metal cross ties
Velocity .....	Infinitely variable
Width .....	1200
Conveying height .....	2180 mm (with hydraulic height adjustment 2560 mm)
Capacity .....	t/h 4000

### Filling capacities

Fuel.....	l	300
Hydraulic system.....	l	200

### Electric system

Voltage .....	V	24
---------------	---	----

Technical modifications reserved. Machines may be shown with options.

## Standard equipment

### Operator's platform

- 2 driver's seats slewable and rotatable
- Protection, dashboard
- Adjustable dashboard
- Hydraulically foldable roof
- Digital display for machine management
- Weather protection roof

### Tractive unit

- Fuel tank 300 litres
- Individual control of bucket flaps
- Track chain scraper
- Rubber floor plates
- Hydraulic hopper front flap
- Cleaning kit
- Pre-installation of swivelling conveyor

### Conveyor belt

- Central lubrication of conveyor belt chain
- Scraper for conveyor belt
- Automatic conveyor belt cleaning system

### Assistance systems

- On-board tool
- Automatic distance control
- Automatic loading assistant
- Laptop Station

### Miscellaneous

- 7 Halogen working lights
- Flashing beacon
- Backup alarm
- 2 x 24 V sockets
- 1 x 12 V socket
- Storage compartments

## Optional equipment

### Operator's platform

- Weather protection for platform
- Comfort seat with seat heating
- Height adjustable lift platform

### Tractive unit

- Special paint finish
- Bio-degradable hydraulic oil
- Camera system
- Signal lamp system

### Conveyor belt

- Slewable belt  
(only for model BMF 2500 S)
- Slewable belt covering
- LED lighting for slewable conveyor
- Camera system for slewable belt
- Hydraulic height adjustment for conveyor belt

### Assistance systems

- Automatic steering (max. 14.0 M)
- Automatic steering (max. 10.0 M)

### Miscellaneous

- Fleet management BOMAG TELEMATIC
- Illumination balloon (24 V, 250 W)
- LED Roof illumination
- LED Illumination of short and medium conveyor belts
- Fire extinguisher
- Coming Home light function
- Illumination of engine compartment

