



# BiG Pack

Large Square Balers



[www.krone.de](http://www.krone.de)



## KRONE – a successful tradition for more than 100 years

- Knowledge
- Innovation
- Close to the customer



KRONE has been a household name in agricultural engineering for more than a century. Starting as a small Blacksmith, KRONE has developed into a leading forage harvesting specialist. The correct mixture of innovative force, closeness to the customer and knowledge are responsible for the sustained success of the company. Numerous innovative and unique features are strong endorsements for the quality and customer-oriented philosophy of the company.



The process starts with many discussions. KRONE employees are in close contact with customers and sales partners. They jointly analyze markets, trends and machine requirements.



New machines are designed with the aid of the latest computer technology. Thanks to innovative design programs, many machine operations can be simulated on the screen. This allows the machine to be optimized continuously during the design phase.



The time arrives for prototype construction. Experienced specialists produce the first prototypes by hand. In close cooperation with the designers, all components are assembled for the first time to produce a new KRONE machine.



A characteristic of KRONE is recognizing trends early on, maintaining a close dialogue with the customer and establishing design trends that set new standards for the market. For example large square balers: From the start KRONE put its R & D resources it building sturdy machines with massive outputs and offering a high degree of operating comfort. With chainless drives, automatic clutches for the pre-compression chamber, an over dimensioned flywheel, compressed air knotter



cleaning and the tandem axle running gear, KRONE fulfilled the requirements of high performance field operation as early as 1994. This is what the KRONE philosophy is all about! Listening very closely to what farmers and contractors require, and then implementing these requirements into the product.



Since computer simulation can't fully replicate field conditions, KRONE puts its new machines through their paces all over the world and under many different operating conditions. By exposing the machines to a broad range of conditions, performance expectations can be assured in the global marketplace of today and tomorrow.

The customer is this last stop in quality control! But before that KRONE has already performed many checks. Quality is documented in all phases of production, including testing by independent agencies who arbitrarily put machines from current production under the magnifying glass.

Satisfied customers all over the world confirm is an expense worthwhile: Made in Spelle means Quality!



## BiG Pack

The Successful Product Line

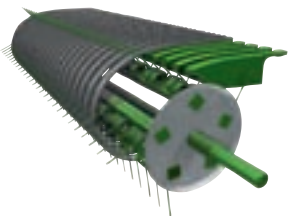

## Easy Flow

The camless Pick-up in a large square baler



## X-Cut

The Cutting System



## PreChop

The Integral Pre-Chopper



## VFS

The Variable Fill System



## Baler Organ

From the Flywheel up to the Roller Ramp



## Knotters – Control Units

Perfectly Tied, Highest Comfort



## Running Gear

Safe, Smooth and Speedy



## BiG Pack 890, 1270, 1290

The Heavy-Duty Models



## MultiBale

Up-to-Nine Single Bales within One



## HDP

Bales like Bricks



## Field Reports

Worldwide Successful



## Technical Data

Technology in Detail





# KRONE – BiG Pack

The product line that secures Success

- EasyFlow  
the camless pick-up
- VFS – the Variable Fill System
- The Crop Cutting System  
X-Cut
- MultiBale system:  
Nine single bales within One
- HDP – Baling with the Highest  
Density



With a KRONE large square baler you purchase experience and competence in baler design. From experience KRONE knows the widely differing field requirements and offers a complete baler range with standard bale chamber dimensions.

Internationally recognized innovations, such as the Variable Fill System (VFS), the unique MultiBale model and the camless EasyFlow pick-up are some reasons for the success of the KRONE BiG Pack. It is a fact: KRONE makes what customers want.



BiG Pack 890 (X-Cut): The smallest of all BiG Packs. With four double knotters and Bale chamber dimensions of 80 cm (2'7.5") height and 90 cm (2'11") width, this machine has proven itself, not only in straw, but also in heavy wet silage.







BiG Pack 1270 (2'x4') (X-Cut): This machine is used in conditions because of its chamber dimensions of 120 cm (3'11") height and 70 cm (2'4") width. Six Single or Double Knotters provide for well-shaped baling in straw, hay and silage.



BiG Pack 1270 (X-Cut/MultiBale): With this version you can pack up to nine small bales in one large bale. Your benefits: The large bales can be cleared quickly from the field and the small bales can be easily distributed.

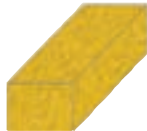

## The BiG Pack range

BiG Pack 890 BiG Pack 890 X-Cut	80 x 90 cm (2'7.5" x 2'11")	
BiG Pack 1270 BiG Pack 1270 X-Cut	120 x 70 cm (3'11" x 2'4")	
BiG Pack 1270 MultiBale BiG Pack 1270 X-Cut MultiBale	9 small bales 120 x 70 cm (3'11" x 2'4") one large bale up to 270 cm (8'10")	
BiG Pack 1290 BiG Pack 1290 X-Cut	120 x 90 cm (3'11" x 2'11")	
BiG Pack 1290 HDP BiG Pack 1290 HDP X-Cut	120 x 90 cm (3'11" x 2'11")	



BiG Pack 1290 (X-Cut): The firm bales with 90 cm (2'11") height and 120 cm (3'11") width are accepted by farmers worldwide. Because of the large bale dimensions, this machine works mainly in straw and hay, but in some countries it is commonly and successfully used in silage as well.



BiG Pack 1290 (X-Cut/HDP): Make bales like bricks. The High Density baling system and the longer bale chamber lead to an increase in bale weight by up to 25 % over traditional systems. This pays for itself quickly when transporting straw.



# EasyFlow

## The camless pick-up in a large square baler

- Clean work
- More throughput
- Quieter running
- Reduced wear
- Less maintenance



With the EasyFlow pick-up KRONE offers a camless pick-up which functions without a complex cam track control. The secret of this pick-up is the wave-shaped design of the tine bands. You get the effect of tine retraction without the cam track drive. EasyFlow can work with 30 % higher speed allowing higher ground speed and an increased throughput.



Nothing is left behind: Working at widths of 1,950 mm (6'5") or 2,350 mm (7'9") (DIN 11220) and specified with five rows of tines that are spaced 55 mm (2.2") apart, the camless EasyFlow pick-up leads to absolutely clean rakes. In addition, no material is pulled into the pick-up, thanks to the 5.5 mm (0.2") tines being arranged at right angles relative to the specially shaped scrapers.

KRONE knows customer needs: The pivotal gauge wheels with pneumatic tires can be adjusted in height without tools, adapting quickly to all conditions. They follow all ground contours and wear/scrubbing when maneuvering around corners is reduced.





The advantages are obvious: The EasyFlow pick-up has clearly fewer moving parts with the elimination of the traditional cam drive design. The lower wear resulting from this is realized in lower maintenance and service costs. EasyFlow works within approx. 30 % higher speed when compared to conventional systems. An improved throwing effect results in the crop's transition from the pick-up to the bale chamber improving the pick-up's capacity and making the BiG Pack even more efficient.

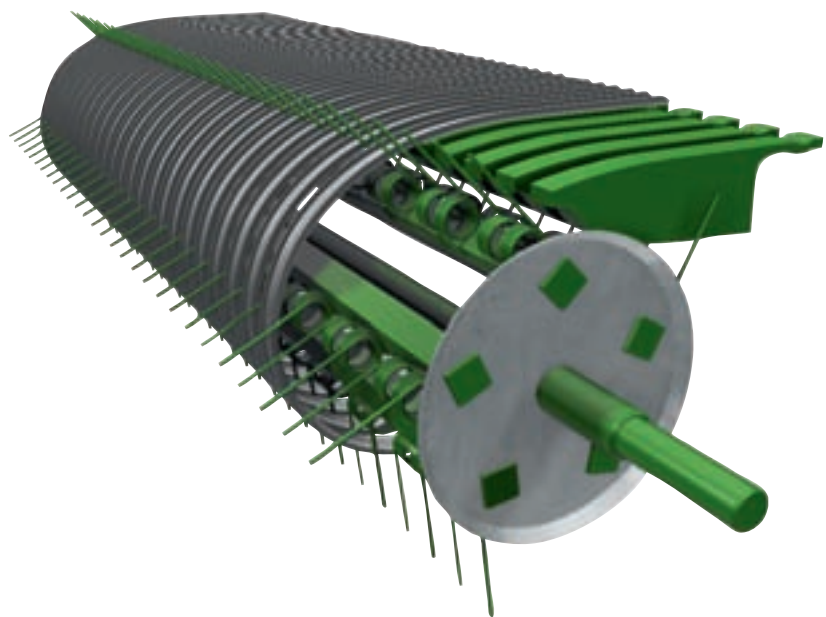

With EasyFlow, KRONE has become first manufacturer in the world to offer as standard camless pick-up for large square balers in the BiG Pack series.



Protects the turf: the passive steered guide wheels are pendulum suspended. They follow all ground contours and wear/scrubbing when maneuvering around corners is reduced.



Making a great feature even better is the continuous crop flow provided by the roller crop guide with integrated deflector plate. The forage is not pushed upwards it is pushed on to the tines which is important in lumpy windrows. Providing consistent crop flow and full utilization of the exceptional pick-up capacity.



The solution for higher operator comfort: The drive through universal shaft with integrated ratchet clutch, which responds to pick-up overload. Changing shear bolts is not required.



# KRONE X-Cut

## Precision cuts

- 16 knives for 80 cm (2'7.5") chamber width
- 26 knives for 120 cm (3'11") chamber width
- Tines feature wide and hard-wearing Hardox steel plates
- The knife bank with pull-out knife trays lowers hydraulically
- Knives are selected in sets
- MaxFlow INSIDE: an optimized crop flow for high throughput



Finest quality cuts! Select 16 or 26 knives to achieve nominal cutting lengths of 44 mm (1.7"). The knife control system activates half of the number of knives or deactivates all knives. As a result, the machine is converted without tools and in no time at all. The feed tines are arranged in a V and are plated with wide Hardox steel to provide finest cuts, highest throughputs and maximum longevity.

The knife floor is adapted to match the crop flow and increases machine efficiency.

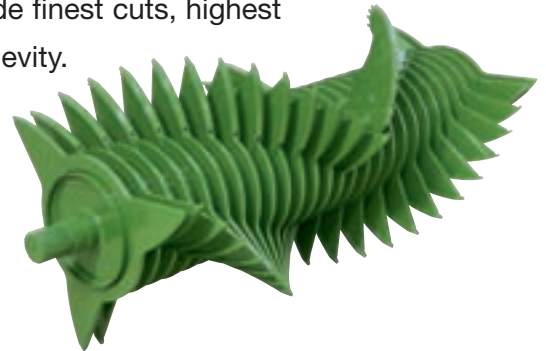

**Strong rotor, strong cut:** The large diameter of 550 mm (1'10") is impressive. The double tines in sets of three across the full width of the cutting and feed rotor pass the crop efficiently across the knives because of the V-shaped arrangement.



**Direct-Drive:** The cutting and VFS rotor is driven directly off the main gearbox. Drive protection is provided by the integrated cam type clutch, which protects the cutting rotor against overload and resets itself automatically.



Wide Hardox plates on the feed tines result in higher throughputs, clean scissor-like cuts and harder wearing. The 20 mm (0.8") wide Hardox feed plates are a guarantee for quality forage. Any mushing is eliminated.

**MaxFlow  
INSIDE**

KRONE X-Cut: The “Tray Principle”. The X-Cut cutting system has two knife drawers with either 8 or 13 knives. The drawers can be lowered hydraulically to install and remove the knives. For this purpose the knife drawers or “divided trays” can be conveniently pulled outwardly to the side. The exposed knives can be removed for maintenance work or for changing the cutting length. The knives can then be refitted. All without tools!



X-Cut safety: The spring protection for individual knives ensures trouble-free working if foreign objects are picked up. The knives conveniently push back into their working position after the foreign body has cleared.

Plugged? – No worries: In the case of blockages the knife trays are lowered hydraulically from the tractor seat. Once the pre-chamber is freed, the knives are brought back into working position.

Quick and easy: The central knife control system sets a variety of cutting lengths. Select half the number of knives to obtain a nominal length of 44 mm (1.7"); select the full set of knives for a length of 88 mm (3.5"). 0 position means the crop is not cut.



# PreChop

## The integral pre-chopper for straw

- Excellent machine throughput – also on pre-chopper versions
- Short chop lengths – down to 21 mm (0.8") nominal length
- Adjustable chop lengths, selectable knife bank
- Defibrillation effect for added liquid absorbing capacity
- Reversible knives for long service life
- Mechanical gearbox and hydraulic height control

PreChop is the integral pre-chopper for the KRONE BiG Pack 1270, 1290 and 1290 HDP big baler ranges. Equipped with 88 rotary knives and two fixed counter banks of knives in a staggered arrangement, the unit chops the crop to nominal lengths of 21 mm (0.8"). More than that, PreChop defibrates the stem visibly. The defibrated crop flows smoothly through the baler and is baled into well-shaped bales that are easy to handle.



The mechanical gearbox that drives the pre-chopper is integrated in the drawbar mounted headstock. The drawbar extension provides for sufficient space between the pre-chopper and the tractor wheels. Chopper activation/deactivation is convenient from a lever.

Positive drive: The chopper rotor is driven by a five-groove poly V-belt, the so-called Power Band. This band is tensioned automatically and designed to transfer high speeds and cope with heavy loads.

Baling without pre-chopping: The PreChop unit lifts hydraulically out of work to enable baling without chopping the crop. It lifts 52 cm (1'8") clear off the ground to allow smooth passage over windrows without picking up material. Vice versa, in work you restrict the depth mechanically to 20 cm - 40 cm (7.9" - 1'4").

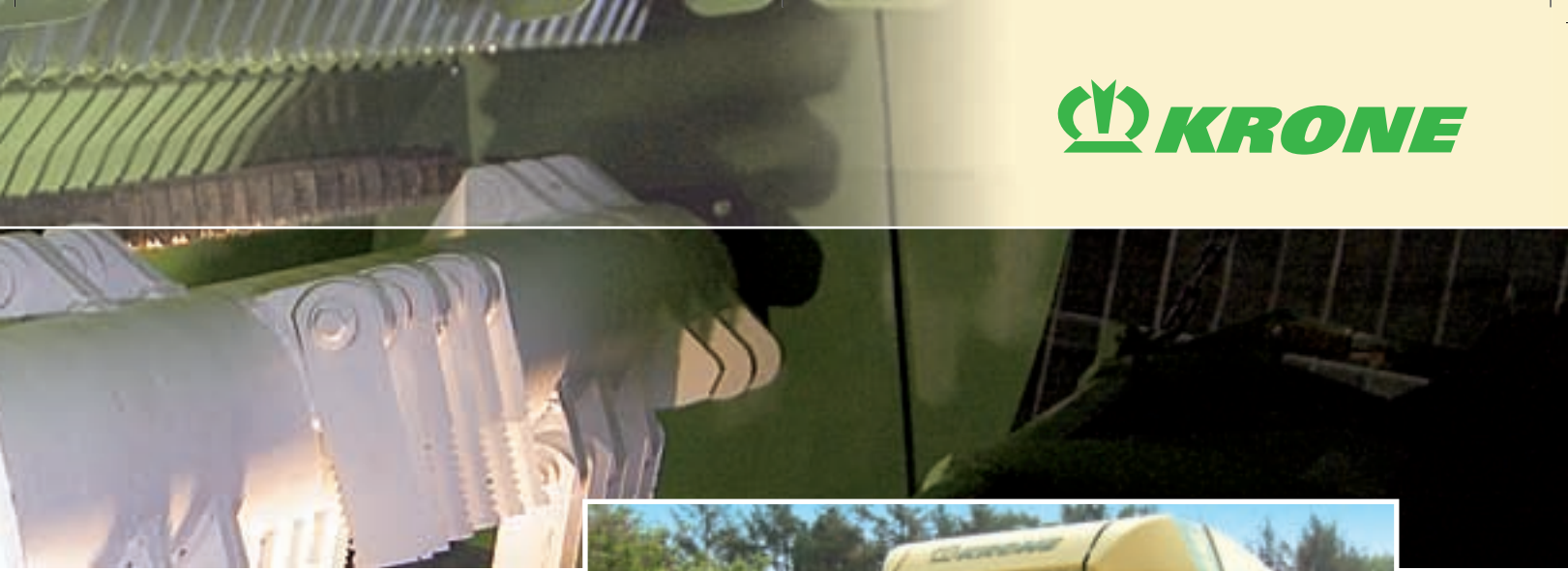

The PreChop system adds value to the crop, because finely chopped and clean straw can be used in a wide variety of applications, including as bedding in poultry buildings and dairy cow beds, in sow and livestock fattening as well as on strawberry plantations and as nutrient medium in mushroom cultivations or as ingredients in low crude fibre rations. If treated, the straw has enhanced absorbing qualities, spreads more easily in the livestock building, and prevents the slurry drains from blocking up while supporting manure mineralization. The KRONE PreChop chopper caters for all these applications.

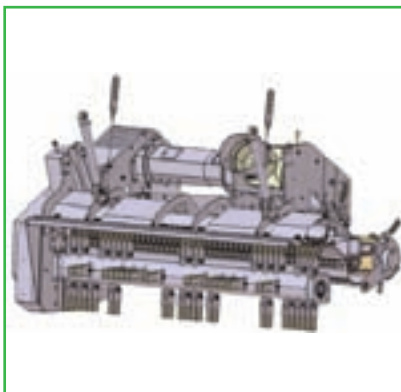

Chopping at its best: The 525 mm (1'8") diameter rotor is equipped with 88 pivoting knives and rotates at 3,000 rpm, pulling the crop through the two rows of fixed knives. The knives are reversible for long service life.



Variable chop lengths: The opposite knives adjust to one of five positions to provide different cutting lengths. Each opposite knife comprises 47 blades.



Straightforward: PreChop is easy to remove when not in use for extended periods of time. After removing the pin and the driveshaft, lower the unit hydraulically onto retractable transport rolls and pull it out to the side.



## VFS – The Variable Fill System from KRONE

Rock Solid Bales Guaranteed, Everytime!

- High throughput, 6-phase feed sequence
- Pre-compression in the feed chamber, thus complete filling of the bale chamber
- Well-shaped bales even from small windrows
- Uniformly compressed bales for higher bale weights
- Automatic overload clutch for higher daily output, no downtime



The Variable Fill System (VFS) from KRONE provides rock solid and well-formed bales, even in small windrows and at reduced forward speeds. The principle of the VFS system: First, the packer and feeder tines convey the crop into the feed chamber where it is collected and pre-compressed. At the point when the feed chamber is completely filled, the feederrake conveys the crop into the bale chamber.



Strong and reliable: The gearbox design provides high efficiency during operation. A cam clutch gives the VF system effective and dependable protection.



The cam type clutch for ultimate convenience: Maximum safety with maximum uptime, the clutch has five positions of the cams. Blockages in the feed chamber can be removed without the driver having to get down from the cab, just lower the PTO speed and the clutch will re-set itself automatically.



With the Variable Fill System KRONE once again offers a solution to improve a farmer's productivity. This is another classic example of the innovative force that characterizes KRONE designs. The VFS system combines the best features of continuous feed systems with the best features of volume-dependent systems and opens up completely new way for KRONE balers to produce exceptional large square bales.

Fig. 1: Fully thoughtout: The VFS system operates with 5 packer rakes and one feeder rake as well as a retainer. The packers are controlled by a common cam track. The feeder rakes by a second rotating cam track.

Fig. 2: As long as the cam track of the feeder is not in the rotated position, the packer and feeder convey the crop permanently into the feed chamber and pre-compress it. The retainer holds back the crop under the bale chamber.

Fig. 3: Only when the feed chamber is full does the retainer hook automatically swing to the rear. This frees the transition into the bale chamber and at the same time releases a clutch.

Fig. 4: The clutch rotates the entire cam track of the feeder rake which now conveys the crop into the chamber. The retainer and feeder rake then swivel back automatically to their starting position.

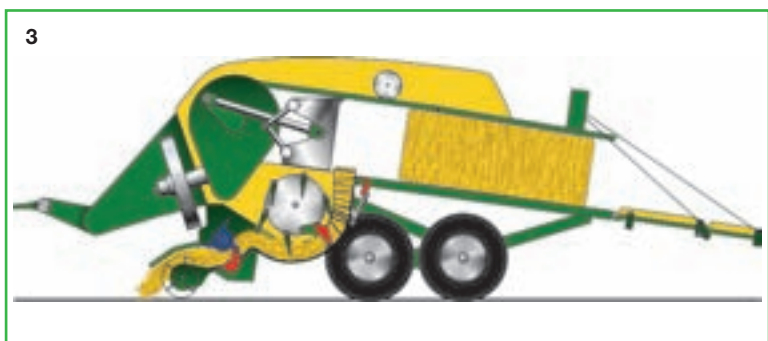
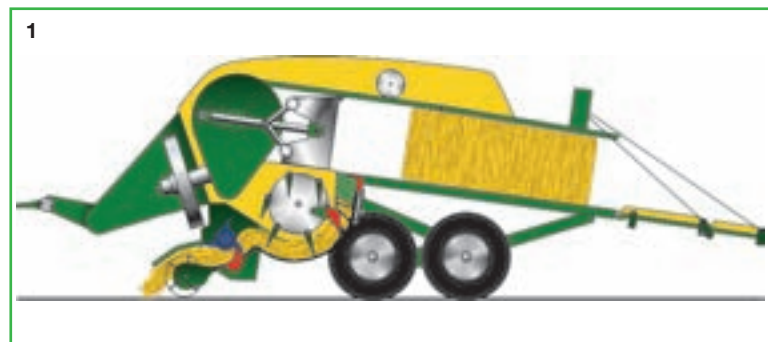



We know it too: Vibration building up and noisy operation – a feature of many traditional baler designs. One more reason why KRONE has used large flywheels right from the start. The massive flywheel in the BiG Pack offers high torque. Load peaks are leveled out, the machine runs evenly and has a considerably lower power requirement. The KRONE BiG Pack large square balers are noticeably different by their quiet operation and smooth transportation.



Exceptional protection of the entire drive: At the front, the BiG Pack is protected by a friction clutch. In the case of overload on the machine side an automatic ratchet protection clutch is activated.



Absolutely safe: For Service and Maintenance work the drives can be locked by a hand brake on the flywheel. This parking brake is standard equipment and prevents the machine from movement while in the parked position.



Without diversions: The power transmission to the packer gear and the knotters is directly through drive shafts instead of chains which are prone to wear and tear plus must be maintained. Customers can be assured of comfort, convenience and reliability with the KRONE direct drive system.





Rock solid bales, hard work in the baking summer heat. This places high demands on the drives of a large square baler. Therefore KRONE has equipped the BiG Pack with an especially powerful main gearbox and chainless drives. The generously dimensioned bevel spur gearbox transmits the power with low power losses. It is extremely quiet running and powerful. According to baler type, these gearboxes can be loaded with more than 1100 HP. The sturdy construction of the gearbox guarantees reliable operation.



Powerful and safe: KRONE equips the large square balers with very long plunger arms providing extra safety, plus it has a depth in the slots of 750 mm (29.5") for extra needle protection. The plunger runs quietly at 50 strokes/min for BiG Pack 890 and 38 strokes/min for all other KRONE large square balers.



High load capacity: The plunger is centered in the chamber by the huge bearings. It can be adjusted in height by eccentric adjustment bolts through the bearings. Plus scrapers are equipped front and back of the bearings to clean the track out for that extra reliability.

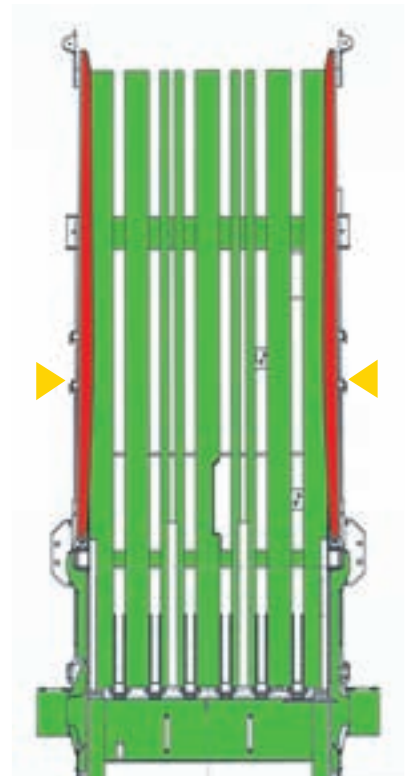

The funnel shaped bale chamber is the answer: For highest bale densities the BiG Packs have long, funnel-shaped bale chambers with spring loaded hay dogs on the sides and top. The round ends of the doors guarantee smooth bale edges.



In good form – you get what you want and more with the KRONE BiG Pack. Rock solid bales with uniform density throughout, and smooth bale edges with no frays. The BiG Pack has made a name for itself with these operating characteristics. The onboard hydraulics with automatic baling force control ensures always uniform, sharply edged bales even in moist and changing crops. The long bale chamber with its hay dogs and its funnel-shaped design guarantees highest baling density.



Self contained, onboard hydraulics: The hydraulic circuit is supplied from a separate onboard oil tank through a high-pressure pump driven by the main gearbox. That means the oil circuit is independent of the tractor hydraulic system, thus eliminating a possible source of contamination.



Uniform bale density over the entire chamber width: Two force sensors on the left and right measure the actual baling force of the plunger. A control system compares these values with the pre-selected baling force and adjusts the pressure on the bale chamber doors accordingly.



Full hydraulic power for rock solid bales: Up to 6 hydraulic cylinders (depending on machine model) operate the upper and side bale chamber doors for highest continuous loading in the bale chamber and bale ramp.



Whether in hay, straw or silage, a large square baler must stay in the field and operate with maximum performance. Only then can the farmers and contractors justify the investment cost. For this reason KRONE engineers never stop designing and improving the KRONE BiG Pack large square balers. Whether working within Europe or abroad, extreme conditions are a way of life and that is where the KRONE BiG Pack excels again and again. The BiG Pack is your guarantee for success.

Straw baling



Hay baling



Silage baling



Bale for bale, consistency in length: The star wheel is mounted in a central location in the bale chamber floor. The bale is pushed over the star wheel providing an exact bale length measurement.

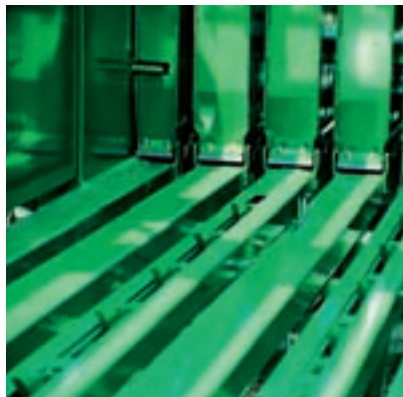

Clear it out and go: The hydraulic bale ejector, positioned in the chamber floor, pushes the last bale completely out of the bale chamber. With an optional comfort monitor, this process is started automatically from the tractor seat.



Simple and robust by design: The heavy-duty roller bale chute is a standard component. The unit folds up hydraulically to make for a compact transport length and is secured with chains in this position.







## Single or Double Knotters

Always a perfect knot

- High functional safety – good twine feed 
- Compressed air cleaning – standard
- Central lubrication – standard
- Reliability built-in

Highly compressed and well-tied bales are always guaranteed with the KRONE knotting system! This knotting technology operates with six knotters (four knotters in the BiG Pack 890) with absolute reliability. All KRONE large square balers with more than 700 mm (2'4") bale chamber height have double knotters as standard.

The BiG Pack 1270 is available with single knotters or optionally with double knotters.



For long working days: 32 balls of twine, 16 rolls per twine box per side! Thus with a total of 32 balls of twine you can bale more than 900 bales without reloading. For your convenience, the twine boxes can be folded up for service work on the machine.



Compressed air cleaning: The air pipes are arranged so that the entire knoter area is kept clean. Compressed air cleaning guarantees consistently high reliability of the knotters – even under extreme operating conditions.



Compressor onboard: Tractors that do not have a compressed air systems, with KRONE no worries as you will get an onboard compressor as standard equipment. Compressed air keeps the knotters clean in all conditions, in all countries. Plus it has a quick coupler so you can blow down the machine yourself after the days work.



The double knotter function: During the baling process, upper and lower twine strands are fed to the bale. These are tied together at the start (starting knot 1) and at the end (ending knot 2) of the bale that is being formed. The lower twine is guided through the needle by a tensioning system that surrounds the bottom and the two ends of the bale. The upper twine is supplied to the bale directly by a tensioning system and does not run through the knotter like a Single knotter. This ensures that the machine can be driven with maximum baling force in all crops without dropping strings.

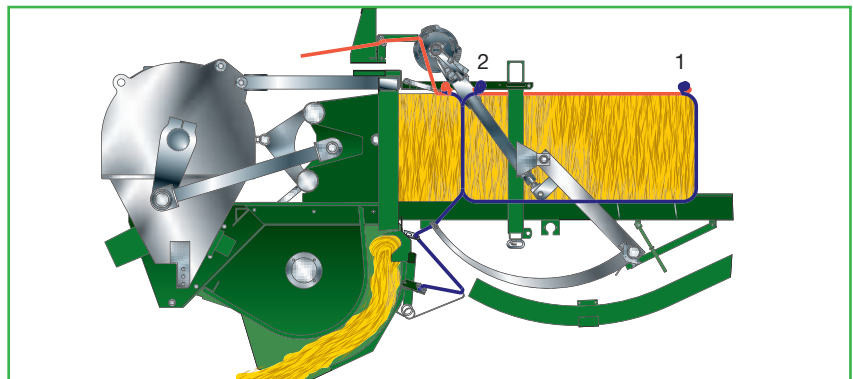
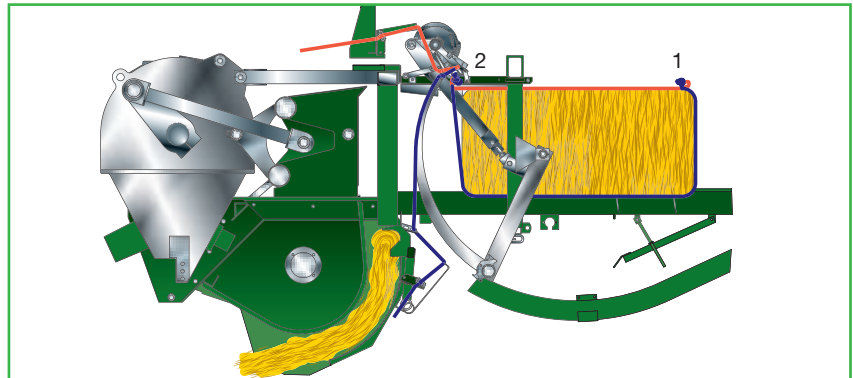

Time saver. The electronic lubrication system greases all assemblies automatically, such as the pick-up system, the VF system and the knotters. The service intervals are set to requirements.



The single knotter is the most favorably priced alternative for bale chamber heights up to 70 cm (2'4"). However, when baling wet material, heavy silage and bale heights of more than 70 cm (2'4"), the double knotter system is recommended. With it you can operate with the highest baling density in all crops. There is no twine breakage, due to twine being fed on both sides, and the twine strands are no longer drawn through the formed bales. There is no twine in the knotter during the baling process. This means less knotter wear. The tension of the lower twine is monitored electronically, that of the upper twine with reflectors that are in sight of the operator.



Operator comfort is key during those long working days and nights. Therefore, BiG Pack is available with a number of optional features to cater for your individual needs. The 'Medium Plus' and 'Comfort' operator terminals provide a clear interface and update the operator on all current machine functions and allow him to interfere instantly as required. Sensors control all major functions such as baling pressure settings, the bale counter and the knotters. The Comfort system offers an easy-to-read graphical display as well as a range of convenient functions including automatic ejection of the last bale and up to 20 bale count memories. Comfort Control is a requirement on the BiG Pack 1270 VFS/XC model with MultiBale. The combination allows you to choose individual lengths when baling small bales.



Always on the safe side: In rare cases of failure with the electrical system you can continue baling in manual mode. By simply adjusting the pressure limiting valve on the machine. This allows the operator to continue working until repair is more convenient.



Convenient: The electric bale length control system is standard specification for precise bale length control. The system allows you to set the desired bale length and trigger the tying cycle from the tractor seat.



Simple: With the Medium controller, the last bale ejector is operated, and the bale ramp is folded up and down by a hydraulic spool valves on the left rear end of the bale chamber.





**CCI ISOBUS:**

The KRONE BiG Pack big balers can be specified with the CCI ISOBUS terminal. The standardized option allows you to operate any machine and a variety of brands from one single terminal, provided the machine is ISOBUS compatible. The new CCI operator box offers a universal control system that provides consistent machine operation to ISOBUS standards. Sharing a similar interface concept, similar menu structures and icons, the box allows users of different machines and makes to instantly come terms with the system. Alternatively, the baler may also be operated from an existing tractor terminal that is ISOBUS compatible.



The onboard computer of the Comfort and Medium controllers coordinates all functions for proper operation and transmits the evaluated data to the controllers. It also monitors and allows adjustment of the bale density control system. And can be ordered with Load Sensing hydraulics/Power-Beyond systems.

Everything is possible: With the Comfort controller the last bale ejector can be operated by the terminal in the tractor cab and by control switches on the rear left side of the machine. The ramp can also be raised up for transport and lowered for fieldwork by pushing a button.

This is comfort: For knife removal or installation the Comfort controller offers the possibility of swinging the cutting system in and out either via the monitor in the tractor cab or by control switches at the front of the baler.



## Field to field, quickly and efficiently



Constantly improving cost efficiency and output! This task has the highest priority at KRONE. KRONE BiG Pack large square balers are mostly used by contractors and must be frequently moved from field to field. The ability to do this in a timely, safe manner is highly dependent on the running gear of the baler. Time is money and transporting at maximum speed is an important factor. The axles of the KRONE BiG Pack balers is rated at 50 km/h (31 mph) allowing operators the maximum, safe transport speed.



**Sure-footed:** In storage position the machine is set down on a hydraulic height-adjustable parking jack. The hydraulic parking jack is available as standard for the BiG Pack 1290 HDP. It is optional for all other balers.



**Suitable for all tractors:** The V-shaped drawbar is sturdy, adjustable in height and highly maneuverable when driving around the tightest corners. The PTO shaft is supported by an intermediate bearing position between the baler and the tractor providing a noticeably quiet, smooth operation of the shaft.



**As an alternative:** Further flexibility in tractor mounting is provided with a drawbar ball (K 80 system) coupling system. Whether using this system or the standard drawbar mounting system, the KRONE BiG Pack balers are designed to fit all makes of tractors.



High speed – uneven roads: With the tandem axle as a steerable unit the BiG Pack can be safely towed up to 50 km/h (31 mph). You master every curve with rear wheel steering. Whether in the field or in transport there is no tire scrubbing. For further operating convenience, the steering axle is brought hydraulically into mid-position and locked for reversing. The sprung steering axle unit can be equipped with the larger 22.5" tires.



The single axle is standard equipment except for the BiG Pack 1290 HDP. This feature includes a 40 km/h (25 mph) rating and large volume tires (except for the BiG Pack 1290 HDP). There are optional tires from 700/45-22.5/12PR up to 800/40 R26.5 according to machine type.



The tandem axle with a parabolic sprung boogie: The large swing distance gives advantages when in transportation and also reduces the ground pressure as it transmits uniform pressure onto the ground.



It is your option: The tandem axles units are available in two versions. The self-steering unit with locking cylinders to enable reversing and is rated to 50 km/h (31 mph).



## BiG Pack 890, 1270, 1290

### Your key to success

- EasyFlow, the camless pick-up 
- The variable fill system
- Double knotters on 700 mm (2'4") bale chamber height as standard equipment
- Compressed air knotter cleaning
- Funnel-shaped bale chamber for higher baling density

Balers that do not compromise. The KRONE large square balers are classic examples of exceptional baling density, output and comfort. With their different chamber dimensions and many unique features, the BiG Pack 890 VFS (XC), 1270 VFS (XC) and 1290 VFS (XC) work in worldwide conditions with absolute success in straw, hay and other crops. With a KRONE large square baler you have the right machine in your fleet: Reliable, powerful and designed for versatile application. Your customers enjoy well-shaped bales and you enjoy satisfied customers.



BiG Pack 890 VFS (XC): Standard equipment is four double knotters, seven spring loaded hay dogs in the bale chamber and three hydraulic cylinders for the upper and side bale chamber doors. Because of the narrow chamber width, the X-Cut cutting system has a maximum of 16 knives.

BiG Pack 1270 VFS (XC): For highest baling densities this machine has seven spring loaded hay dogs in the bale chamber and four hydraulic cylinders for the bale chamber doors. It is possible to choose between single and double knotters.

BiG Pack 1290 VFS (XC): This machine has nine spring loaded hay dogs in the bale chamber and four large hydraulic cylinders for the upper and the two side bale chamber doors. The six double knotters are standard.



A large square baler is not a large square baler. Along with maximum output and reliability, contractors and farmers also always demand innovative technology and machines with extensive standard equipment and special equipment that enables higher efficiencies. Here KRONE offers constantly new solutions for its BiG Pack series. The latest examples of this are the camless EasyFlow pick-up, the packer drive with cam type clutch, the VFS variable fill system, the double knotter, the MultiBale system and, of course, the self-steering tandem axle. These innovations and details as are required by serious operators.



Standard roller bale chute and hydraulic ejection of the last bale: The rollers reduce the strain on the chute and ensure the bales are quickly and gently placed on the ground. The roller chute folds hydraulically into transport position.



Everything under control: The KRONE BiG Pack balers are available with optional CCTV camera and a colour-screen monitor. The monitor is specified for use with an additional camera.



Harvesting quality: The optional moisture sensor updates the operator on the condition of the baled crop. The information is read out on a cab-based monitor.



# KRONE MultiBale

## Small bales within a large bale

- Up to 9 single bales in one large bale
- Bale lengths as required: from 0.30 m to 1.35 m (1' to 4'5")
- Simple handling with small bales
- BiG performance in the field: Easy handling on the farm



MultiBale – An EXCLUSIVE from KRONE on the BiG Pack 1270: Up to nine single bales in one large bale. The award-winning MultiBale method simplifies handling. The length of the small bales can be adjusted from 30 cm (1') to 135 cm (4'5"). In operating the MultiBale a conventional large bale, up to 270 cm (8'10") long can be baled, which contains up to nine smaller bales. The MultiBale system provides its owner with access to a wider customer base and outstanding flexibility in bale packages.



**Up to nine bales in one!**

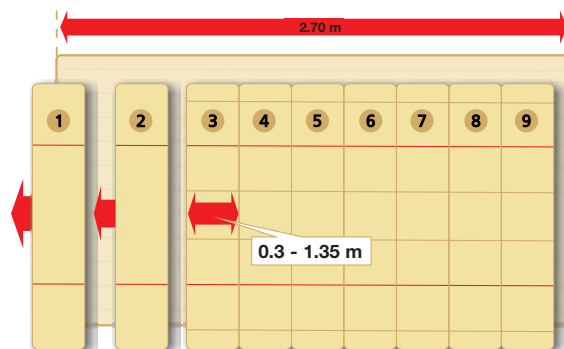

Large becomes small. During operation the driver sets the required small bale on the control panel in the tractor cab. The bale length of the small bales can be set continuously from 45 cm (1'6") to 135 cm (4'5") on the control terminal of the Comfort controller. The smaller single bales are bound by two strings, the entire bale by four strings. Naturally you can also work with conventional full size single bales, all tied with six strings.

Two or six knots: The twin string guide of the upper and lower needles the double knotter makes it possible. The knotter will only work when it is fed with twine. In forming multiple bales the needles of string 1, 3, 4, 6 are not swung into the knotter system therefore it will not tie off the strings, but when a needle is present in knotter 2 & 5 it will tie off a knot. Means when no needle is in the knotter it is inactive.



An operator's dream come true from KRONE: The MultiBale system for KRONE BiG Pack large square baler 1270 VFS (XC) with double knotters and Comfort controller. With MultiBale the field is quickly baled and large bales made of small bales can be delivered to the customer. The length of the entire bale as well as the number of small bales can be set conveniently and simply on the terminal in the tractor cab. The MultiBale system has become a very popular model straight after its introduction to the market, because it has filled a significant need and wish of contractors and farmers. To make small conventional bales from a high output large square baler, to reduce costs, time and handling.

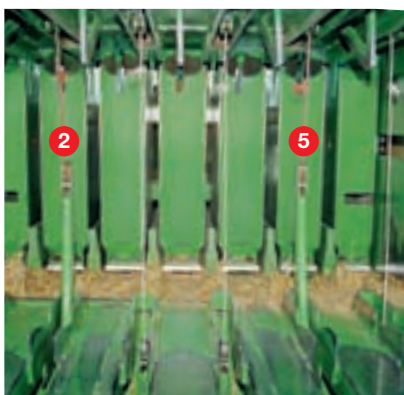

Two strings for the small bale: Each small bale is tied by two knotters. The two strings securely hold the small bales in shape for further transport and distribution.

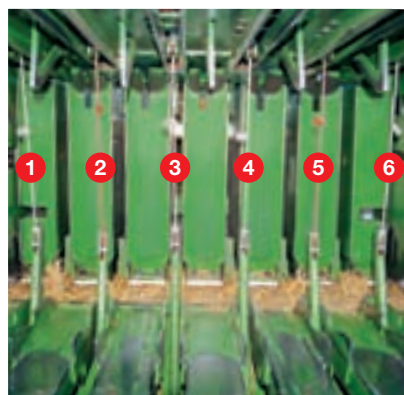

Six twines for the entire bale: With the MultiBale, large bales up to 270 cm (8'10") long can also be baled. Both needle yokes are coupled to the knotters in this setting and the knotters are synchronized to tie all the knotters at the same time.

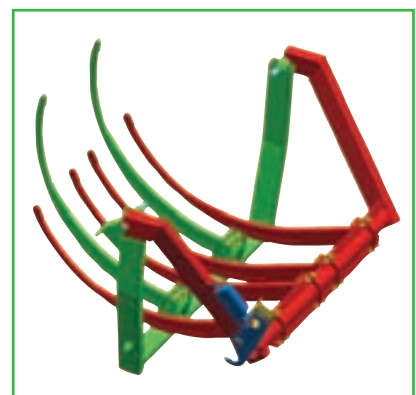

The KRONE MultiBale capability is achieved with a divided needle yoke: The two needle yokes are coupled or uncoupled by a controlled latch. This can be activated and monitored from the tractor seat.



# BiG Pack 1290 HDP (High Density Press)

## Bales like bricks

- Highest Baling Density
- Up to 25% higher bale weights
- Extended bale chamber
- Strong direct drives
- 6 double knotters for standard twine
- X-Cut cutting system optional



HDP (High Density Press) is the all-new, innovative solution from KRONE for high-density bales. The KRONE BiG Pack 1290 HDP with the chamber dimensions of 120 x 90 cm (3'11" x 2'11") and an extended bale chamber opens up new bale packaging possibilities with its baling density. In comparison to conventional large square balers, the large bales of the HDP achieve an increased bale weight up to 25%.



The gigantic main gearbox equates to rock solid, highly compressed bales. The bevel spur gearbox is designed for the highest continuous loading in hard use, transmits more than 830 kW/1100 HP.



Getting into swing: The starting aid is available as an option and starts the baler hydraulically to take load off the tractor. Once the baler is running, the tractor pto takes over.



The extended bale chamber: Straw bales 500 kg (1,102 lbs) in weight, 235 cm (7'9") long. The BiG Packs 1290 HDP have proven this result several times in straw. The strengthened bale chamber with a funnel shape, extended by 80 cm (2'7.5"), insures an increased bale density up to 25 % higher than a typical bale of the same dimensions.





If it is a question of professional straw harvesting with bale weights of more than 500 kg (1,102 lbs), the solution is the KRONE BiG Pack 1290 HDP large square baler. This baler is designed for the highest output. Starting from the camless EasyFlow pick-up, the variable fill system, the massive flywheel, the powerful gearbox, the double knotters with compressed air cleaning, all the way up to the extended bale chamber, everything is in its place and ready to go. Utilize this leap in technology for the economic success of your operation.



For highest density: The plunger is designed and reinforced for maximum strength to withstand the highest loads. Six hydraulic cylinders generate the force on the side bale chamber doors allowing the operator to make rock solid large bales.



Operator convenience: The BiG Pack 1290 HDP (XC) is equipped with a standard roller ramp. The operator from the tractor seat using the terminal of the Comfort controller can operate the last bale ejector.



X-Cut: The demand for cut straw is increasing. One more reason for optional equipment on the BiG Pack 1290 HDP X-Cut system with the proven 26-knife cutter the number of knives can be selected from 0 to 26. With the knives in you will achieve higher bale densities and finer cutting which is wish for pig or poultry farmers for easier distributing.



## Up to 25 % more weight per bale: BiG Pack 1290 HDP (XC)

- Fewer bales per acre i
- Faster baling of the field
- Lower transportation costs
- Up to 5 tons higher payload per truck
- Reduction of labor costs
- Smaller storage space needed



Operating profits and cost effectiveness of straw baling depends very much upon the baling, transportation and storage costs. KRONE has the answer with the HDP system. With up to 25 % higher bale density you reduce the production costs per ton during baling and the storage cost per ton after baling, and transportation costs per ton during distribution. The professional marketing of straw now has an increased profit potential. The KRONE large square baler HDP 1290 (XC) can insure of your success. Working hard or working smart!



It's worthwhile: At a straw yield of 8.2 mt/ha (3.3 tons/acre) and a bale weight of 500 kg (1,102 lbs) you have four bales per hectare less to load in comparison with a conventional large square baler with 400 kg/bale (882 lbs/bale). High-quality twine with a specification 130 m/kg must be used to ensure the bales hold together. This high quality twine can be directly ordered from KRONE. The twine costs per tonne of crop are reduced with higher bale density too.



Highest tonnage on the smallest area: Locations and the right areas for storage facilities are hard to find plus getting very expensive these are decisive factors for making profit in professional marketing of straw. Because of the high baling density you save space with the bales from a BiG Pack 1290 HDP. The uniform and sharp-edged bales can be stacked especially well. An additional benefit is that the rock solid bales are relatively insensitive to the influence of moisture and rain.



With full load: Rising fuel prices and highway toll charges increase freight costs dramatically. For this reason it is very important that a truck with a permissible gross weight of 40 t is fully loaded, as the costs remain the same even if the payload is not fully utilized. Tests have shown that up to 5 tons more can be loaded with the HDP bales. The calculation is quite simple: At an unloaded weight of the truck of 15.5 t you come to 24.5 tons load with HDP bales 500 kg (1,102 lbs) in weight, to only 19.5 tons with bales 400 kg (882 lbs) in weight.



Citation from a driving impression of the German agricultural machinery magazine **profi**:

KRONE BiG Pack 1290 HDP:

## Rock-hard bales

HDP stands for High Density and is Krone's magic formula for baling big, high-density bales. **profi** took the BiG Pack 1290 HDP model to the field for an exclusive driving impression to find out about the technology the North German manufacturer uses to advance into dimensions of baling that seemed inconceivable up to now. (...) Our highly condensed conclusion: The new KRONE BiG Pack HDP is a very intriguing machine for those who are into professional straw harvesting and transportation. After all, a 25-30% increase in bale density is a word (and obviously means fewer bales, too). With this in mind, the 25% price premium over a regular BiG Pack model as well as the higher input requirement are really "peanuts" in view of the fact that higher-density bales allow for added truck loads of 5 to 6 tonnes – quite an advantage in times of toll roads and rising diesel fuel prices.

Citation from **profi** 10/2005 pp30



Donald Shiermeier, Fairfield, Idaho (USA)

### **"BiG Pack with variable feed system"**

I like the feeding system on the KRONE baler. It seems to be more gentle on the hay. The maintenance part of the KRONE baler is very attractive as well; the auto lube system greases everything but the drivelines. It's also a very smooth running baler, which equates to less wear.





Ton Verschoor, NL

### High-density and just right for transport

“As a straw harvesting and transport specialist we have relied on KRONE-BiG Pack HDP balers for a long time. We currently operate eleven BiG Pack 1290 HDP units. What we really like about these balers is the fact that they really produce high-density bales that will not loose their shapes. Our experience is that HDP bales are at least 30 percent heavier than those bales we produce with a regular KRONE 1290 baler. Now, loading 52 bales on one truck, we can use truck capacity to full potential, both as to weight and volume. This is a huge advantage as we transport straw down to Austria and Italy, covering distances as large as 600 km. Storage of HDP bales is also more efficient. When you stack 12 bales onto each other, the bale at the bottom carries a load of about 5,500

kg (12,125 lbs). This is no problem for a HDP bale, which is firm and solid throughout - in the middle, on the corners and along the edges. There is no fraying. Another important point is that all bales are absolutely identical in size. For example, in Southern Europe, straw bales are transported in 40-foot containers, which are unforgiving about varying bale sizes. If the bales differ in size, there is no chance to attain the target load. All this is no problem for KRONE HDP bales, which are all the same size. On balance, I'd say, contractors who also take care of the straw logistics will find a BiG Pack HDP is paying off quickly.”





## Technical Data BiG Pack

		890	890 XC	1270
Chamber width & height	approx. mm (inch)	800 x 900 (2'7.5" x 2'11")	800 x 900 (2'7.5" x 2'11")	1,200 x 700 (3'11" x 2'4")
Bale length	mm (inch)	1,000 - 2,700 (3'3" - 8'10")	1,000 - 2,700 (3'3" - 8'10")	1,000 - 2,700 (3'3" - 8'10")
Power requirement	from kW/HP	90/122	95/130	93/127
Pick-up working width DIN	mm (inch)	1,950 (6'5")	1,950 (6'5")	2,350 (7'9")
Length in transport position	mm (inch)	7,930 (26')	7,930 (26')	7,930 (26')
Length in working position	mm (inch)	9,180 (30'1")	9,180 (30'1")	9,180 (30'1")
Height	mm (inch)	3,075 (10'1")	3,075 (10'1")	2,875 (9'5")
Width	mm (inch)	2,550 (8'4")	2,550 (8'4")	2,995 (9'10")
Weight	approx. kg (lbs)	6,580 (21'7")	7,480 (24'7")	7,240 (23'9")
Tires single axle 40 km/h (25 mph)		700/45-22.5	700/45-22.5	700/45-22.5
Tires tandem axle 50 km/h (31 mph)		500/50-17 500/55-20 620/40-22.5	500/50-17 500/55-20 620/40-22.5	500/50-17 500/55-20 620/40-22.5
Brakes*		2-circuit compressed air*	2-circuit compressed air*	2-circuit compressed air*
String Storage	rolls	32	32	32
Single knotter		–	–	standard
Double knotter		standard	standard	optional
Knives max.		–	16	–
Minimum cutting length	mm (inch)	–	44 (1.7")	–
Stroke length	mm (inch)	750 (2'6")	750 (2'6")	750 (2'6")
Ram strokes	per minute	50	50	38
PTO shaft		Wide angle with overrun clutch	Wide angle with overrun clutch	Wide angle with overrun clutch

\* Country-specific also available with hydraulic brakes

**Service is the first order at KRONE.** Our global distributors and dealers are trained regularly and informed about all innovations, maintenance and service matters. KRONE's international factory training and engineering team visits customers all over the world. They have one goal: to keep improving the most innovative baler in the world. WE LISTEN TO OUR CUSTOMERS. As a customer we know you won't tolerate downtime causing your harvesting train to stop. Every minute is important. KRONE operates a total of over 2,100 spare parts stores worldwide. Every dealer or distributor can be supplied with spare parts within hours, keeping you in the field. Look for the KRONE dealer or distributor in your area.



1270 XC	1290	1290 XC	1290 HDP	1290 HDP XC
1,200x700 (3'11"x2'4")	1,200x900 (3'11"x2'11")	1,200x900 (3'11"x2'11")	1,200x900 (3'11"x2'11")	1,200x900 (3'11"x2'11")
1,000 - 2,700 (3'3" - 8'10")	1,000 - 2,700 (3'3" - 8'10")	1,000 - 2,700 (3'3" - 8'10")	1,000 - 3,200 (3'3" - 10'6")	1,000 - 3,200 (3'3" - 10'6")
100/136	105/143	112/152	140/190	147/200
2,350 (7'9")	2,350 (7'9")	2,350 (7'9")	2,350 (7'9")	2,350 (7'9")
7,930 (26')	7,930 (26')	7,930 (26')	8,850 (29')	8,850 (29')
9,180 (30'1")	9,180 (30'1")	9,180 (30'1")	9,940 (32'7")	9,940 (32'7")
2,875 (9'5")	3,075 (10'1")	3,075 (10'1")	3,110 (10'2")	3,110 (10'2")
2,995 (9'10")	2,995 (9'10")	2,995 (9'10")	2,995 (9'10")	2,995 (9'10")
8,430 (27'8")	7,860 (25'9")	9,050 (29'8")	10,200 (33'6")	11,500 (37'9")
700/45-22.5	700/45-22.5	700/45-22.5	–	–
500/50-17 500/55-20 620/40-22.5	500/50-17 500/55-20 620/40-22.5	500/50-17 500/55-20 620/40-22.5	500/55-20 620/40-22.5	500/55-20 620/40-22.5
2-circuit compressed air*	2-circuit compressed air*	2-circuit compressed air*	2-circuit compressed air*	2-circuit compressed air*
32	32	32	32	32
standard	–	–	–	–
optional	standard	standard	standard	standard
26	–	26	–	26
44 (1.7")	–	44 (1.7")	–	44 (1.7")
750 (2'6")	750 (2'6")	750 (2'6")	750 (2'6")	750 (2'6")
38	38	38	38	38
Wide angle with overrun clutch	Wide angle with overrun clutch	Wide angle with overrun clutch	Wide angle with overrun clutch	Wide angle with overrun clutch

**The beauty of a low price fades when low parts quality stops your harvest chain.** Low parts prices are a strong temptation. The convincing story about good quality from the spare parts dealer around the corner often proves to be a fairy tale. Reports in professional journals have proven that quality tested by the manufacturer lasts longer and functions more safely. Do not compromise. Trust KRONE original spare parts.



# **KRONE** Internet



Discover the world at KRONE and browse through our website pages to find facts and figures and also new developments plus a wide range of services. Explore our website and find out how versatile the KRONE world is.



## News

Click here to find up-to-the minute information about KRONE – from new product presentations to show reviews. Here you are at the pulse of KRONE life.



## Products

Find extensive information on our full product range. This section holds everything you need – from video clips to manuals.



## Sales organisation

Here you find a distributor in Japan as well as your local KRONE dealer who will be pleased to support you. This is where you find your KRONE partner who will be pleased to assist you.



## Jobs

Would you like to join our company? KRONE is often looking for diligent and motivated staff to work at our farm machinery factory as well as at our commercial trailer production plant. So, this section is always worth a visit.



## Media center

The KRONE 'database' holds thousands of documents, pictures, test reports and much more. Here you find very detailed information on KRONE products that are of special interest to you.



## Events

Are you in for a KRONE live experience? Check out for KRONE events and look at a machine on show or watch it during a demonstration. After all, there is little that is more effective than a hands-on experience.



## Service

Here you find all the service information you require – from a point of contact at the factory to finance schemes for your KRONE machine as well as training schemes for staff and users.



## Download Center

Are you looking for a KRONE calendar for your desktop or a smart picture for your presentation? Here, at the KRONE download center, you will find plenty of useful material for a wide range of projects.



## Used Machinery

KRONE often has a wide range of demonstration or exhibit machinery on offer. This is a good site to find your KRONE machine. Then contact your local KRONE dealer to arrange the details of a potential purchase.



## Parts

24/7... This service gives you the opportunity to find your KRONE part at any time and without waiting. The KRONE Agoparts Portal has an article number and exact description for every part. You can order the part instantly at your local KRONE dealer by sending an e-mail to Agoparts.



## KRONE shop

Are you looking for a gift or are you a collector of farm models? Then you should definitely shop around at our KRONE shop. We take your orders at any time of the day.

Your KRONE dealer

## Maschinenfabrik Bernard KRONE GmbH

Heinrich-Krone-Straße 10  
D-48480 Spelle

Telefon: +49 (0) 5977.935-0  
Telefax: +49 (0) 5977.935-339

info.ldm@krone.de  
www.krone.de