

BD14W

WHEEL DOZER



Salient Features :

- Turbo charged sturdy engine
- Electronic Transmission
- Articulated Power steering
- Limited slip differential
- Center point articulation
- Greater drawbar pull



BD14W

Blade Capacity : 2.4m³

Flywheel Power (net) : 94kW(126 HP) @ 2000 r/min

Operating Mass : 15000 kg

www.bemlindia.com

BD14W

WHEEL DOZER

Salient Features :

Sturdy direct injection type, turbo charged BEML Diesel Engine for sustained power and fuel economy.

Articulated power steering for higher maneuverability and faster cycles.

Limited slip differential front and rear axles for positive traction while loading.

Rear axle oscillation offers stability to the machine on rough and uneven terrains.

Centre point articulation for safer steering operation. The rear wheels always track the front wheels.

Neutral starter switch in the circuit to avoid engine starting when transmission gear shift lever is not in neutral.

Greater drawbar pull and faster cycle time for higher production.



ENGINE

Make	BEML LTD.
Model	BS6D105-1
Type	Water cooled 4 cycle, over head valve, direct injection type, turbo charged diesel engine.
No. of Cylinders	6
Bore & Stroke	∅ 105 x 125 mm
Displacement	6.51 (6,499 cc)
HORSE POWER	
Rated BHP	110 kW(148 HP) @ 2000 rpm
Flywheel power	94 kW (126 HP) @ 2000 rpm
Maximum Torque	565 Nm (58 kgm) @ 1400 rpm
FUEL SYSTEM	
Type	BOSCH type, MICO FIP system
Governor	Mechanical, all speed control
LUBRICATION SYSTEM	
Method	Gear pump, forced lubrication
Cooler	Water cooled
ELECTRICALS	
Starting Method	Electric
Starting Motor	24V, 4.5kW
Alternator	24V, 45A
Battery	24V (2x12V), 150Ah

TRANSMISSION

TORQUE CONVERTER	
Model	W340
Type	Hydrodynamic
Stall Ratio	3.095 : 1
Transmission	
Model	4WG190 ERGO POWER
Type	Rear mounted multi speed power shift electronic control transmission with four forward & three reverse speeds
Controls	Manual Range Selector

AXLES & FINAL DRIVE

Type	Front axle is fixed, and Rear axle oscillates up or down by 10°, (total 20°) for greater machine stability.
Final Drive	
Type	Four wheel drive, full floating with planetary reduction in each wheel.

Travel Speeds	
Forward km/h (m/s)	Reverse km/h (m/s)
1st 6.28 (1.74)	1st 6.61 (1.84)
2nd 11.66 (3.24)	2nd 12.24 (3.4)
3rd 21.43 (5.95)	3rd 22.34 (6.2)
4th 31.4 (8.72)	---

STANDARD ACCESSORIES

Ammeter, Engine oil pressure gauge, Water temperature gauge, Transmission oil temperature gauge, Engine hour meter, Horn, Starter key switch, Engine oil temperature gauge, Working and traveling lights, Foot Throttle, Fenders, Starting motor, Alternator, Regulator, Batteries, Canopy, Reverse light and alarm, Side indicator lamps, Fire extinguisher, Tool box, Brake and Tail lamp, Battery charging indicator, High beam indicator, Parking brake applied indicator, Low air pressure warning.

OPTIONAL ACCESSORIES

Towing winch	
Steel rope length 50 m	Traction force 8000 kg
Tractor speed 10.5 m/min (1st layer)	
Winch length 900 mm	Width 700 mm
Height 825 mm	
Trench digger	
Scoop capacity 300 ℓ	Scoop width 752 mm
Swing arm turning angle 180 °	
Cycle time	22.5 sec
Mass	4700 kg
Control valve (Trench digger)	6 spool for swing, boom, arm, stabilizer and bucket.
Crane Hook	
Lifting capacity	2 tonne
Max. lifting height from ground level	4700 mm
Max. swing radius with respect to front axle centre	6150 mm



HYDRAULIC SYSTEM

Pump Type	Vane Pump
Capacity	176 litres/min @ 2000 rpm
Relief Pressure	13.73 MPa (140 kg/cm ²)
Control Valve Type	Double spool type
Positions	
Lift System	Raise, Hold, Lower and Float
Winch (Optional)	In, hold and out



FILTRATION

Engine	Replaceable micro paper element filter for lubrication as well as for fuel line is provided.
Transmission	Replaceable element type of filter is provided.
Hydraulic System	Magnetic plug and replaceable element type filter is provided.



COOLING SYSTEM

Radiator	Continuous finned flat tube de-aeration type tank
Pump	Centrifugal pump
Fan	Blower type
Air cleaner Type	Dry, 2-stage, horizontal
Air Compressor	
Capacity	160 CC



BRAKES

Service Brakes	Wet multiple disc type. Air over Hydraulic actuated.
Parking Brake	Disc type, spring applied and hydraulic released operating pressure @ 126 kg/cm ² .



TYRES AND RIMS

Tyres	
Standard	18.00 x 25-24 PR, L-4 (Tube less)
Optional	20.5 x 25-20 PR
	23.5 x 25-20 PR
Sand Tyres	21.0 x 25-15 PR
Rims	
Type	Flange type
Size	13.00 x 25
Max. gradeability	25% (~14°)



DIMENSIONS

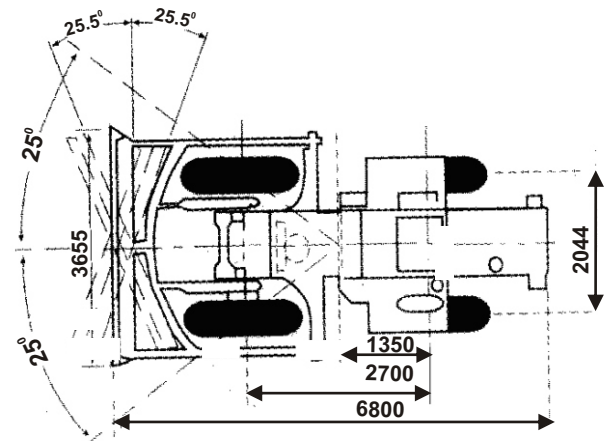
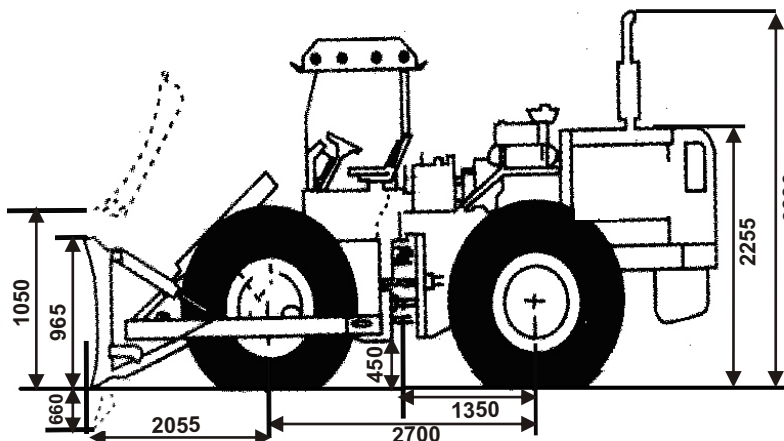

DIMENSIONS

	(OPTIONAL)
Machine length with trench digger	8675 mm
Width	2500 mm
Height over exhaust	3330 mm
Ground clearance	450 mm
Min. turning radius	6000 mm
Max. height over trench digger	5840 mm
Blade Capacity	2.4 m ³



SERVICE CAPACITIES

System	(litres)
Cooling system	45
Fuel tank	185
Crank case engine	25
Transmission (inclusive of drop box)	27
Front axle	35
Rear axle	35
Brake oil tank	2.8
Hydraulic tank	195



BLADE

Type	Angling & tilting
Mass (kg)	1645
Digging angle	55°
Blade angle	25.5°
Blade length x height (mm)	3655 x 965
Max. lift above ground (mm)	1050
Max. drop below ground (mm)	660
Max. tilting adjustment (mm)	400
Blade capacity	2.4m ³



OPERATING MASS

Operating mass	15,000 kg approx.
----------------	-------------------



STEERING SYSTEM

Type	Articulated, full power steering 25° on either side.
------	--

Steering Pump	
Type	Vane Pump
Flow	141 l/min @ 2000 rpm
Relief Valve Setting Pressure	17.61 MPa (175 kg/cm ²)
Turning Radius	7200 mm

Material and specifications are subject to change without notice, Illustrations may include optional equipment & accessories

BD14W

WHEEL DOZER

TECHNICAL SPECIFICATIONS

बी ई एम एल लिमिटेड

BEML LIMITED

A Govt. of India Miniratna Company Under Ministry of Defence

Business Network

Corporate Office

BEML Soudha, 23/1, 4th Main,
S.R. Nagar, Bangalore-560 027

T + 91 80 22963240, 22963250

F + 91 80 22963278/516/280/164

E-mail: office@cpd.beml.co.in
office@pr.beml.co.in

International Business Division

BEML Soudha, 23/1, 4th Main,
S.R. Nagar, Bangalore-560 027

T + 91 80 22222730, 22233350
22963187, 22963215

F + 91 80 22224874

E-mail: office@export.beml.co.in

Marketing Division

5th Floor, Unity Building,
J.C. Road, Bangalore-560 002

T + 91 80 22963501/02/07/510/553

F + 91 80 22963541

E-mail: m@beml.co.in
bemldealer@dealer.beml.co.in

Global Service HQ

C-6, Central Hingna Road,
MIDC Industrial Area, Hingna,
Nagpur-440 028

T + 91 7104 287097/287098

F + 91 7104 287099

E-mail: ss.servicehq@gmail.com
ss@servicehq.beml.co.in

REGIONAL OFFICES

Bilaspur

1/A, Sector-C, Sirgitti Industrial Area,
P.O: Tifra, Bilaspur - 495 223.
Chhattisgarh.

T + 91 7752 252745, 252598
F + 91 7752 252065
E-mail: bilaspur@rm.beml.co.in

Chennai

Flat No. 10&11, Supriya Estates,
Sterling Road, Nungambakkam,
Chennai - 600 034, Tamil Nadu

T + 91 44 28276576 / 28220844
F + 91 44 28257319
E-mail: chennai@rm.beml.co.in

Dhanbad

Kamal Kunj, Kola Kusuma,
Saraidhela, Dhanbad - 828 127
Jharkhand

T + 91 326 2200180 / 2208982/5827
F + 91 326 2200182
E-mail: dhanbad@rm.beml.co.in

Hyderabad

3-6-114, Himayat Nagar,
Hyderabad - 500 029
Andhra Pradesh

T + 91 40 23225250 / 7032 / 2166
F + 91 40 23221794
E-mail: hyderabad@rm.beml.co.in

Kolkatta

35/1, Taratalla Road,
Kolkatta - 700 088.
West Bengal

T + 91 33 24015286 / 87 / 98 / 99
F + 91 33 24015288
E-mail: kolkatta@rm.beml.co.in

Mumbai

Rajmahal, 84 Veer Nariman Road,
Church Gate,
Mumbai - 400 020, Maharashtra

T + 91 22 22042533 / 22049490
F + 91 22 22852633
E-mail: mumbai@rm.beml.co.in

Nagpur

33, Cement Road,
Shivaji Nagar,
Nagpur - 440 010, Maharashtra.

T + 91 0712 2248435 / 2248343
F + 91 0712 2249997
E-mail: nagpur@rm.beml.co.in

New Delhi

Flat EFGH, 'Vandana', 11th Floor,
Tolstoy Marg,
New Delhi - 110 001

T + 91 11 23310035 / 23316500
F + 91 11 23325085
E-mail: delhi@rm.beml.co.in

Ranchi

206/D-1, Bhagirathi, (Behind NCC Campus),
Rameshwaram Colony, Bariatu Road,
Ranchi, Jharkhand - 834009

T + 91 651 2540710 / 2540791
F + 91 651 2540624
E-mail: ranchi@rm.beml.co.in

Sambalpur

BEML Complex, NH-6, Baraipalli,
Sambalpur - 768 150
Orissa.

T + 91 663 2521604 / 2520393
F + 91 663 2521603
E-mail: sambalpur@rm.beml.co.in

Singrauli

PB No. 5, Jhingurda Colliery,
Sidhi, Singrauli - 486 889
Madhya Pradesh.

T + 91 7805 268260 / 266668
F + 91 7805 267282 / 318
E-mail: singrauli@rm.beml.co.in

www.bemlindia.nic.in

Represented by :



DISTRICT OFFICES

Ahmedabad

266-1, Dilbaug Villa,
Darshan Society Road, Navrangpura,
Ahmedabad - 380 009. Gujarat

T + 91 79 26445523
F + 91 79 26423950
E-mail: ahmedabad@rm.beml.co.in

Asansol

3, Burnpur Road,
Asansol - 713 304
West Bengal

T + 91 341 2252480
F + 91 341 2250601
E-mail: asansol@rm.beml.co.in

Bacheli

Behind Central Stores
of NMDC Ltd., Depot 5, Bacheli - 494 553.
Chhattisgarh

T + 91 7857 200518
F + 91 7857 230005
E-mail: bacheli@rm.beml.co.in

Bhilai

Room No. 22/C, BSP Building,
Near Ispat Bhavan, Bhilai - 490 001
Chhattisgarh.

T + 91 788 2223882, 2894721
F + 91 788 2221652
E-mail: bhilai@rm.beml.co.in

Bhopal

Ground Floor, Hall No.1, Chittod Complex
Zone-1, Maharanapratap Nagar (MP Nagar)
Bhopal - 462 023

T + 91 755 2550711
E-mail: bemlbhopal@gmail.com

Bhubaneswar

252/A, LEWIS Road,
Bhubaneswar - 751 014
Orissa

T + 91 674 2434428
T/F + 91 674 2434427
E-mail: bhuvaneshwar@rm.beml.co.in

Chandrapur

Mamidwar, Tiles Factory Compound,
Ghugus Road, Padoli,
Chandrapur - 442 406 Maharashtra

T + 91 7172 287230
F + 91 7172 287072
E-mail: chandrapur@rm.beml.co.in

Cochin

No. 55/845, Chittor Road, Ernakulam South
Cochin-682 016

T + 91 484 2375138
E-mail: bemlkochi@gmail.com

Guwahati

Hegrabari Road, House No. 11,
Ganesh Puri, Dispur,
Guwahati - 781 006 Assam

T + 91 361 2232966
F + 91 361 2232967
E-mail: guwahati@rm.beml.co.in

Hospet

L-8, KSSIDC Industrial Area,
Dam Road, Hospet - 583 203
Karnataka

T + 91 8394 223173
F + 91 8394 230172
E-mail: hospet@rm.beml.co.in

Jammu

62C, Block D/C, Gandhi Nagar,
Jammu tawi - 180 004
Jammu and Kashmir

T + 91 191 2430447
F + 91 191 2477469
E-mail: jammu@rm.beml.co.in

Kothagudem

Old Project Planning Department,
Near SCCL Corporate Office,
Kothagudem - 507 101, Andhra Pradesh

T + 91 8744 245572
F + 91 8744 245530
E-mail: kothagudem@rm.beml.co.in

Madurai

9-4/49, Kalai Nagar, IInd Main Road,
Madurai - 625 017, Tamil Nadu.

T/F + 91 452 2649458
E-mail: madurai@rm.beml.co.in

Neyveli

F-4, Rajendraprasad Road, Block-27
Neyveli - 607 803. Tamil Nadu

T/F + 91 4142 268517
E-mail: neyveli@rm.beml.co.in

Goa

67-12, Dattaprasad Building, III Floor, MG Road,
Timphoni School, Panjim - 403 001. Goa

T/F + 91 832 2225135
E-mail: goa@rm.beml.co.in

Ramagundam

Opp. SCCL 11A Mines, Manthani,
(PO) Jallaram, GK - 505 184
Karimnagar Dt. Andhra Pradesh

T + 91 8728 248299
F + 91 8728 247423
E-mail: ramagundam@rm.beml.co.in

Udaipur

20-B, Uchhab Bhawan, Bedia Road,
Fatehpura, Udaipur - 313 004.
Rajasthan

T + 91 294 2452053, 2452055
F + 91 294 2452054
E-mail: udaipur@rm.beml.co.in

Visakhapatnam

No. 8-45-11, 4h Lane, China Weltair Colony,
Visakhapatnam - 530 003

T/F 0891 2754608
E-mail: vizag@rm.beml.co.in

Form No. BD14W/001/07/2013