

TECHNICAL DATA

REFUSE COMPACTOR

BC 473 RS-3

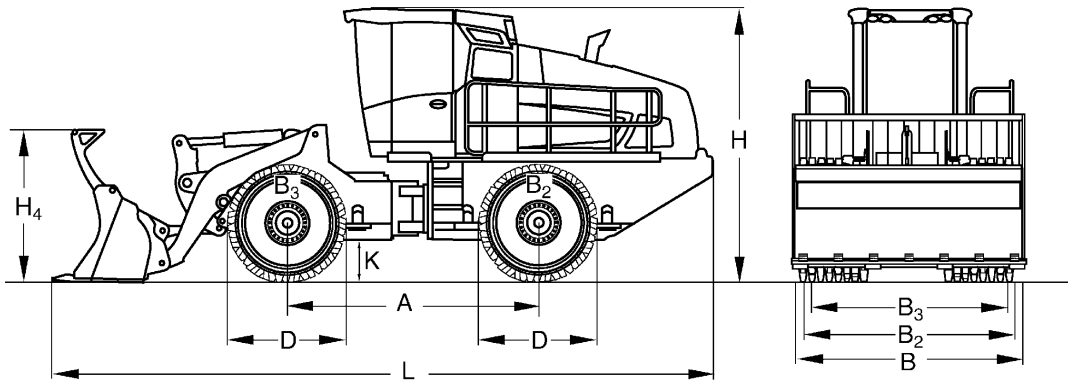



Dimensions in mm

	A	B	B2	B3	D	H	H4	K	L
BC 473 RS-3	3500	3198	3110	2885	1660	3820	2130	600	9230

Shipping dimensions in m3

BC 473 RS-3	112,757
--------------------	---------

Technical Data

BOMAG BC 473 RS-3

Weights

Grossweight	kg	26.500
Operating weight CECE	kg	25.400
Axle load, front CECE	kg	12.300
Axle load, rear CECE	kg	13.100

Driving Characteristics

Speed (1), forward	km/h	0- 4,5
Speed (1), reverse	km/h	0- 4,5
Speed (2), forward	km/h	0- 12,0
Speed (2), reverse	km/h	0- 12,0
Max. gradeability (dep. on soil con.)	%	100
Max. pushing force	kN	281

Drive

Engine manufacturer		Deutz
Type		TCD 2013 L06 4V
Emission stage		Stage IIIa / TIER3
Cooling		Liquid
Number of cylinders		6
Performance ISO 9249	kW	227,0
Performance SAE J 1349	hp	304,0
Speed	min-1	2.200
Travel system		hydrost.
Operating voltage	V	24

Compaction Wheels

Width, front	mm	900
Width, rear	mm	900
Outer diameter (front)	mm	1.660
Outer diameter (rear)	mm	1.660
Number of teeth/cutters, front		40
Number of teeth/cutters, rear		40
Compaction coverage per side	mm	1.013

Brakes

Service brake		hydrost.
Parking brake		hydromec.

Steering

Steering system		oscil.artic.
Steering method		hydraulic
Steering angle +/-	grad	35
Oscillating angle +/-	grad	15
Track radius, inner	mm	3.762

Capacities

Fuel	l	375,0
Hydraulic oil	l	260,0

Technical modifications reserved. Machines may be shown with options.

Standard Equipment

Optional Equipment

- Premium compaction wheels with highly wear resistant teeth
- Central lubrication system
- CD-Radio
- Pre start cabin heating
- Rotary beacon
- Fire extinguisher
- Special painting
- Electrical anti-theft system with numerical code
- Tool kit
- Protective grille for cabin
- TELEMATIC POWER
- Climatronic
- Tachograph
- Cold start device
- Protective ventilation system (Pre-installation)
- Bucket tooth system
- LED Working head lights

