

**AIRMAN**<sup>®</sup>

# Mini-Excavator

Our new AIRMAN series operator-friendly mini-excavator, AX10u-4 offers improved serviceability and safety, in addition to basic operations including digging, loading, and leveling.

**AX10u-4**

**1,110kg** **0.022m<sup>3</sup>**  
Operating weight    Bucket Capacity



## ◆ Workability

- When passing through a narrow pathway or gate on the way to the job site, the machine width can be contracted (910mm). The machine width can be extended (1000mm) during operation to ensure stability. The crawler can be extended or contracted according to the situation.

## ◆ Safety

- Use the lock lever to lock the levers for front, swing and travel operation, thereby preventing improper operation.
- The machine utilizes a mechanism for starting the engine in neutral with the lock lever in the locked position.

## ◆ Serviceability

- Front hoses are stored in the arm to protect them from damage. Articulated hose is used to make it easy to replace if it is damaged.
- A fully openable engine cover has been utilized.

## ◆ Operability

- Use of the hydraulic pilot makes for smooth and light operation.

## Adjustable undercarriage width

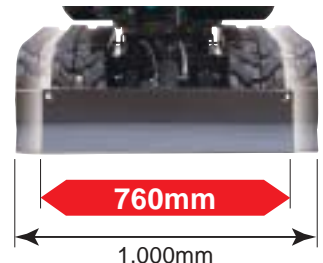

**HOKUETSU INDUSTRIES CO., LTD.**

## ■ Dimensions

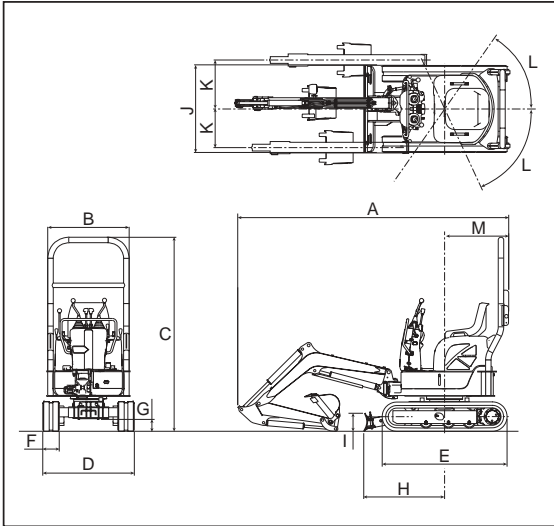

## ■ Working Ranges

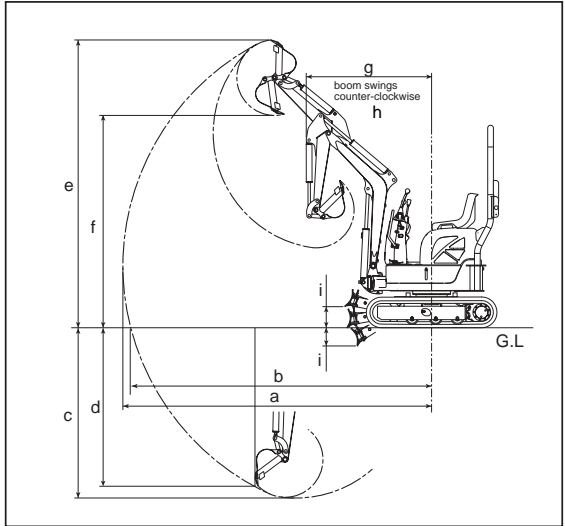

## ■ Specifications

Item	Model	AX10U-4
<b>● Summary Specification</b>		
Type of shoe		rubber
Operating weight	kg	1,110
Bucket capacity	m <sup>3</sup>	0.022
Bucket width with sidecutter	mm	370
<b>● Diesel Engine</b>		
Model		Yanmar 3TNV70
Type		water cooled 4-cycle 3-cylinder swirl chamber type
Piston displacement	L	0.854
Rated output	kW/min <sup>-1</sup>	9.5/2,100 (12.9PS/2,100rpm)
<b>● Hydraulic Devices</b>		
Main pumps (Max. oil flow)	L/min	gear type (10.6) × 2
Pilot pump (Max. oil flow)	L/min	gear type (5.3) × 1
Main relief set pressure	MPa	17.7 (180kgf/cm <sup>2</sup> )
Swing motor		High torque orbit motor
Travel motor		High-torque, 2-speed axial piston motor through planetary reduction gear
<b>● Max. Digging Force</b>		
Bucket	kN	11.8 (1,200kgf)
Arm	kN	6.0 (610kgf)
<b>● Speed (2 speed system)</b>		
Travel speed (high/low)	km/h	4.0 / 2.0
Swing speed	min <sup>-1</sup>	8.5
Gradeability degree	°	30 (58%)
<b>● Others</b>		
Ground pressure	kPa	24 (0.25kgf/cm <sup>2</sup> )
Fuel tank	L	16.0
Hydraulic tank (Hydraulic system)	L	12 (18)
Engine oil	L	2.8

## ■ Dimensions & Working Ranges

Item	Model	AX10U-4
A : Overall transport length	mm	2,970
B : Overall width	mm	910
C : Overall height	mm	2,150
D : Undercarrage width (extend/retract)	mm	1,000 / 760
E : Undercarrage length	mm	1,360
F : Shoe width	mm	180
G : Ground clearance	mm	130
H : Horizontal distance of blade	mm	885
I : Blade height	mm	200
J : Blade width (extend/retract)	mm	1,000 / 780
K : Boom offset distance (Left/Right)	mm	L420 / R535
L : Swing angle to the Right/Left	°	R55 / L65
M : Rear-end swing radius	mm	830
a : Max. digging radius/reach	mm	3,220
b : Max. digging reach at ground level	mm	3,140
c : Max. digging depth	mm	1,780
d : Max. vertical wall depth	mm	1,670
e : Max. cutting height	mm	3,010
f : Max. dumping height	mm	2,220
g : Front min. swing radius	mm	1,310
h : Minimum swing radius at boom swing	mm	1,100
i : Lift capacity (highest/lowest from ground)	mm	220 / 190
<ul style="list-style-type: none"> <li>● Thoroughly read the operation manual before using this machine to ensure correct and safe usage.</li> <li>● Specifications and appearance are subject to change without notice.</li> <li>● The photos used in this catalog were taken specifically for the catalog. When you leave the machine, be sure to follow the instructions in the operation manual.</li> </ul>		

**AIRMAN** is a registered product trademark of Hokuetsu Industries, Co., Ltd.

## HOKUETSU INDUSTRIES CO., LTD.

8TH Floor Shinjuku San-Ei Bldg,  
22-2 Nishi-Shinjuku 1-Chome, Shinjuku-ku, Tokyo 160-0023 Japan  
TEL: 81-3-3348-7281 FAX: 81-3-3348-7289  
E-mail: [oversea@airman.co.jp](mailto:oversea@airman.co.jp)  
<http://www.airman.co.jp>

## HOKUETSU INDUSTRIES EUROPE B.V.

Breguetlaan 12, 1438 BC Oude Meer, The Netherlands  
PHONE: 31-20-6462636 FAX: 31-20-6462191  
e-mail: [info@hokuetsu.nl](mailto:info@hokuetsu.nl)

## SAFETY

- Operate safely in accordance with proper operation manual.
- To prevent trouble and accidents, perform daily and preventive maintenance checks without fail.



ISO9001 : JQA-0581  
ISO14001 : JQA-EM4670

No.2 AX10U-4EU 07-08 ①