



MANUAL ACDE TANK CUTTER

06-2019

CONTENTS

1 Foreword	4
2 Accident prevention instructions	4
2.1 Explanation of the symbols used in these operating instructions	4
2.2 Safety instructions for the various operating stages	5
3 Marking according to machinery directive 2006/42/CE	7
3.1 Tank shear identification	7
3.2 CE name plate of tank shear product group	8
4 General information	8
4.1 Intended use	8
4.2 Other than intended use	9
4.3 Applications	9
4.4 Contents delivered	9
5 Components	10
6 Transport	11
6.1 Transport by crane	11
6.2 Transport using a forklift truck	12
6.3 Transport using a lorry	12
6.4 Storage	13
7 Installation	13
7.1 Agents/consumables	13
7.1.1 Mineral hydraulic oil	13
7.1.2 No mineral hydraulic oil	14
7.2 Preconditions	14
7.2.1 Conversion from hammering to cutter operation	15
7.2.2 Checking a possibly existing cutter system	15
7.3 Mechanical mounting aspects	15
7.3.1 Attaching the adapter	15
7.3.2 Attachment to the boom stick	16
7.4 Hydraulic mounting aspects	17
7.5 Disassembling	18
8 Operating the tank shear	19
8.1 Starting up	19
8.1.1 Switching the tank shear on/off from the carrier	21
8.1.2 Frontal position	21
8.1.3 Functional test	22
8.2 Using the tank shear	22
8.3 Instructions on the correct use of the tank shear	23
8.4 Underwater use	26
8.5 Working in high ambient temperature	26
8.6 Working in low ambient temperature	26
8.7 Putting the system out of operation	27

9 Maintenance	27
9.1 General information	27
9.2 Maintenance schedule	29
9.2.1 Maintenance after the first 10 operating hours	29
9.2.2 Daily maintenance (at least every 10 operating hours)	29
9.2.3 Weekly maintenance (at least every 50 operating hours)	30
9.2.4 Monthly maintenance	30
9.2.5 Yearly maintenance (at least every 1500 operating hours).....	30
9.3 Maintenance activities	31
9.3.1 Lubrication	31
9.3.2 Torques for screw connections	33
9.3.3 Checking the blade clearance	33
9.3.4 Correcting the blade clearance	35
9.3.5 Reversing and replacing blades	35
9.3.6 Hard facing for cutter jaws	36
10 Troubleshooting	37
10.1 The tank shear does not work	37
10.2 Shearing capacity of tank shear insufficient	37
10.3 The tank shear does not cut	38
10.4 The tank shear cannot be rotated	38
10.5 Operating temperature too high	38
10.6 Oil leaks from hydraulic ports	38
10.7 Insufficient lubrication	38
11 Disposal	39
12 Technical specifications	40
13 Guarantee	41

1 Foreword

Please read this operating manual before using your Tank shear for the first time so as to avoid errors and breakdowns through incorrect usage.

These operating instructions contain:

- important safety instructions
- operating instructions for the tank shear
- maintenance instructions for the tank shear
- troubleshooting hints

The operating instructions describes how to use the tank shear on site and should therefore be kept in the document compartment of the excavator cab. Please pay careful attention to the safety regulations which are listed at the beginning of this manual and repeated in the relevant sections. Responsibility for the observation of these safety regulations lie at all times with the operator, i.e. you. All safety regulations listed in this manual comply with the laws and regulations of the European Union. Additional national regulations have also been taken into consideration wherever applicable. Tank shear operation outside the European Union is subject to the laws and regulations valid in the country of use.

2 Accident prevention instructions

Familiarise yourself with the operating manual and the applicable instructions and regulations before starting work with the tank shear.

When using the tank shear in member states of the European Union, the regulations contained in the EC machinery directive 2006/42/CE must be observed and followed, as must all applicable national accident prevention regulations.

In countries outside the European Union, the valid local statutes and regulations shall apply where relevant.

The excavator manufacturer's safety instructions apply when transporting the excavator with the tank shear mounted on it.

2.1 Explanation of the symbols used in these operating instructions

To emphasise their importance, certain points in the operating instructions are marked with symbols.

The form and meaning of these symbols are described below:



designates a hazard or a dangerous activity which MAY lead to personal injury or material damage if the warning is not heeded.



designates a hazard or a dangerous activity which MAY lead to severe personal injury or fatal injury if the warning is not heeded.



designates an imminent hazard which will ABSOLUTELY lead to severe personal injury or fatal injury if the warning is not heeded.

Note

A text marked with the phrase Note provides instructions on the correct use of the hydraulic tool aimed at avoiding incorrect operation or errors during work.

2.2 Safety instructions for the various operating stages

To avoid the risk of injury please observe the following instructions!

When carrying out cleaning, assembly, disassembly, maintenance and transport take care to place the tank shear in a stable position and prevent rotation with the anti-rotation locking pins. The relative movement of the various parts should be prevented by external forces (ex. ties, supports, blocks etc.). Remove the locking pins before putting the tank shear into operation.

Transporting the tank shear:

When transporting the tank shear, use only the lugs provided and hoisting equipment of sufficient capacity!

The tank shear must be placed on the load-bearing surface of a transport vehicle and secured so that it cannot slide away or topple over.

When the shear is transported by crane, there must not be any people within the range of the suspended load.

Mounting the tank shear:

Before mounting the tank shear to the carrier ensure that the hydraulic system has been depressurised! (see *section 9.1*)

The presence of people between the cutter arms is not allowed. There is a risk of people being crushed when the cutter arms close unexpectedly!

Check the nominal width of the hydraulic lines on existing hydraulic systems! All supply and return lines for the hydraulic oil must have a sufficient inside diameter and wall thickness. (See *section 12*).

Use only hoses/pipes which satisfy the following quality criteria: Hydraulic hoses according to standard SAE 517 or DIN EN 856. Hydraulic pipes: seamless, cold drawn steel pipes to DIN EN 10305.

Check the connections to the tank shear and the hydraulic hoses!

Check the connecting threads to ensure that they are undamaged. Sand or other foreign bodies in the threads must be cleaned away.

Do not run any hydraulic lines through the driver's cab!

Hydraulic lines may spring a leak or even burst. The hydraulic oil becomes very hot during operation and has a high pressure.

Mounting the tank shear requires the presence of an assistant, who must be instructed by the carrier driver.

The carrier driver and assistant should agree beforehand on clear hand signals.

When attaching the adapter use only the special steel screws included in the supply.

The tank shear should only be mounted on a carrier with sufficient load capacity! (See *section 12*).

Carriers below this weight class will not provide the required degree of stability and could even fall over during cutter use, causing injury and damage.

If the tank shear is mounted on a carrier above this weight class excessively high mechanical loads may be applied to the mounted attachment.

Never use your fingers to check bores or fitting surfaces. There is a risk of your finger being crushed or cut off!

If you have any questions on the required hydraulic power and its application, please contact our Customer Support Department.

Check the pressure relief valve on the hydraulic system for the cutter circuit for the exact target value setting!

Collect any oil which runs out and dispose of it in accordance with the applicable statutory provisions to avoid environmental hazards.

Operating the tank shear:

Observe the safety instructions of the excavator manufacturer!

The excavator manufacturer's instructions apply when using the excavator, also referred to as carrier in this document, for cutter operation.

The tank shear is only to be used for the applications described.

Close the front screen/splinter guard on the driver's cab to protect the driver from flying splinters of rock during tank shear operations.

The tank shear should only be operated from the driver's cab! Exception: remote carrier control. (See *section 8.1.1*).

Do not start up the attachment until both carrier and tank shear is in the correct position. Remove the anti-rotation locking pins before putting the tank shear into operation.

Stop the tank shear immediately if anyone enters the danger zone!

During tank shear operation the danger zone is considerably greater than during the excavation operation – on account of fragments of stone and pieces of steel flying around – and for this reason, the danger zone must, depending on the type of material to be worked on, be enlarged correspondingly, or secured in a suitable manner through corresponding measures.

Only use hydraulic oils that have been approved by the carrier manufacturer! All mineral hydraulic oils recommended by the carrier manufacturer are suitable for operating the cutter. The use of other hydraulic oils is only allowed upon request.

Only use hydraulic oils of sufficient viscosity!

In summer and in tropical climates, the minimum requirement is a hydraulic oil of type HLP 68.

The temperature of the hydraulic oil must be monitored to ensure that it does not exceed 80 °C. At temperatures below minus 20 °C the tank shear must not be operated while the hydraulic oil is still cold!

For maintenance and repair work:

When carrying out cleaning, assembly, disassembly, maintenance and transport take care to place the tank shear in a stable position and prevent rotation with the anti-rotation locking pins. The relative movement of the various parts should be prevented by external forces (ex. ties, supports, blocks etc.).

Before carrying out any maintenance or repair work on the hydraulic system of the tank shear/the carrier, ensure that the hydraulic system has been depressurised!

(see section 9.1) The presence of people between the cutter arms is not allowed. There is a risk of people being crushed when the cutter arms are closed unexpectedly!

Observe the maintenance intervals specified in the maintenance schedule!

Carry out the checks for wear and the status checks listed there!

Removing the tank shear:

Before removing the tank shear ensure that the hydraulic system has been depressurised!

(see section 9.1) Removing the tank shear requires the presence of an assistant, who must be instructed by the carrier driver.

The carrier driver and assistant should agree beforehand on clear hand signals.

Observe the excavator manufacturer's safety instructions!

The excavator manufacturer's instructions apply when putting the excavator out of operation.

Never use your fingers to check bores or fitting surfaces. There is a risk of your finger being crushed or cut off!

The oil may be very hot. There is a risk of burns!

Oil-carrying parts will be very hot after operating the tank shear. There is a risk of burns!

Collect any oil which runs out and dispose of it in accordance with the applicable statutory provisions to avoid environmental hazards.

Lay the tank shear on wooden supports after removing it to prevent it from falling over.

3 Marking according to machinery directive 2006/42/CE

3.1 Tank shear identification

The nameplate fitted as shown in the diagram serves to identify the tank shear.

This data facilitates easy and correct identification in the event of future correspondence. This is important when ordering spare parts!

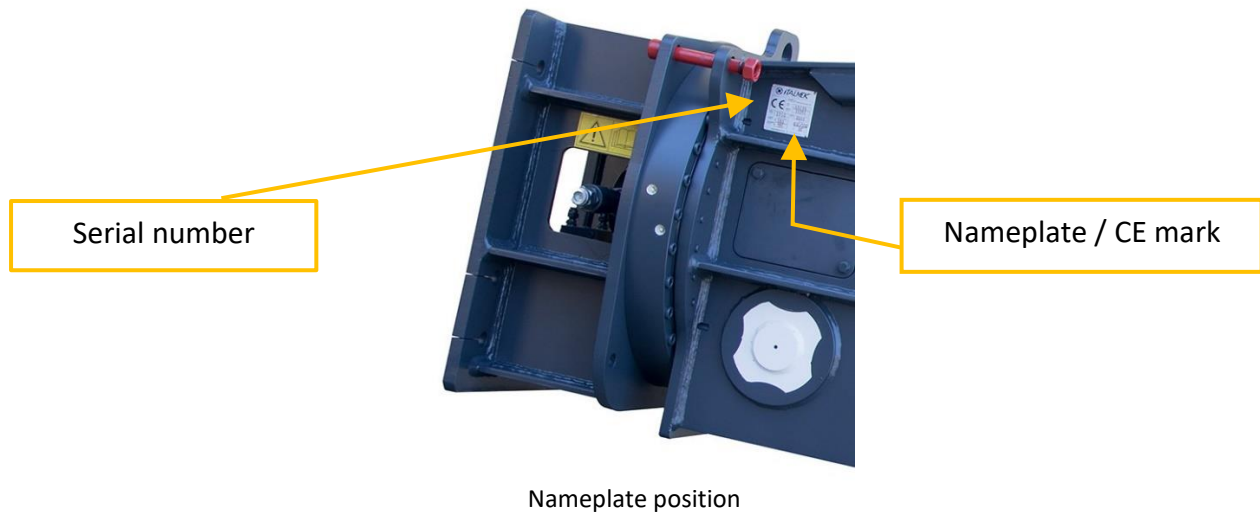

3.2 CE Nameplate of tank shear product group

The CE nameplate contains information on the tank shear. The weight indication refers to the weight of the tank shear.

When selecting hoists and suspension aids for transporting the unit, the weight of the adapter may also have to be considered. In accordance with EC directives, the nameplate must be affixed firmly and in a clearly visible position.

Should these nameplates be lost or defaced, replacements can be ordered to your ACDE dealer.

4 General information

The tank shear was developed to cut tanks and metal sheets in order to prepare them for transport or melting. The tank shear mainly consists of high-strength, low-wear steel. This leads to little wear and a good mechanical resistance.

The hydraulic cylinder produces the high cutting force.

Overturnd cylinder: for the particular conformation of cylinder is the tube that is moved by the hydraulic action while the chromium-plating rod stands still inside the equipment, in order to avoid damaging caused by demolition material.

The 360° rotation capability makes it possible to quickly and accurately manoeuvre the cutter into the position required for the specific application.

A valve protects the hydraulic motor from being overloaded.

4.1 Intended use

The tank shear is an attachment suitable for mounting on hydraulically operated excavators with sufficient load capacity.

After mounting the tank shear, it is powered by the carrier. The maximum operating pressure must never exceed the pressure indicated on the nameplate.

The cutter is operated by the driver from the

excavator's driver's cab. The cutter can only be operated by a qualified excavator driver who has read and understood these operating instructions.

The tank shear must only be used for cutting metal structures (supports, sections, cables, rods)

Modifications or changes to the tank shear are only allowed if agreed with Italmek srl and approved in writing.

4.2 Other than intended use

The tank shear must never be used by non-authorized, non-qualified personnel.

Any other use shall not be considered as intended use.

ACDE Europe BV does not assume any liability for damage caused by other than intended use.

In particular, the tank shear must never be used for:

- pulling,
- hammering,
- levering,
- pushing aside,
- impacting,
- hitting or
- transporting suspended loads.

4.3 Applications

No part of the excavator and the tank shear shall come within 10 m of live power lines.

There must not be any pipes carrying gas or pressurized liquids inside the cutter's working range.

Underwater use of the tank shear is not allowed.

When using the tank shear in very high or low outside temperatures, the viscosity of the hydraulic oil must be sufficient for the relevant application. See the instructions in [section 8.6](#).

The temperature of the hydraulic oil must not exceed 80 °C.

4.4 Contents delivered

The tank shear delivery contains:

- tank shear
- operating instructions
- EC declaration of conformity

5 Components

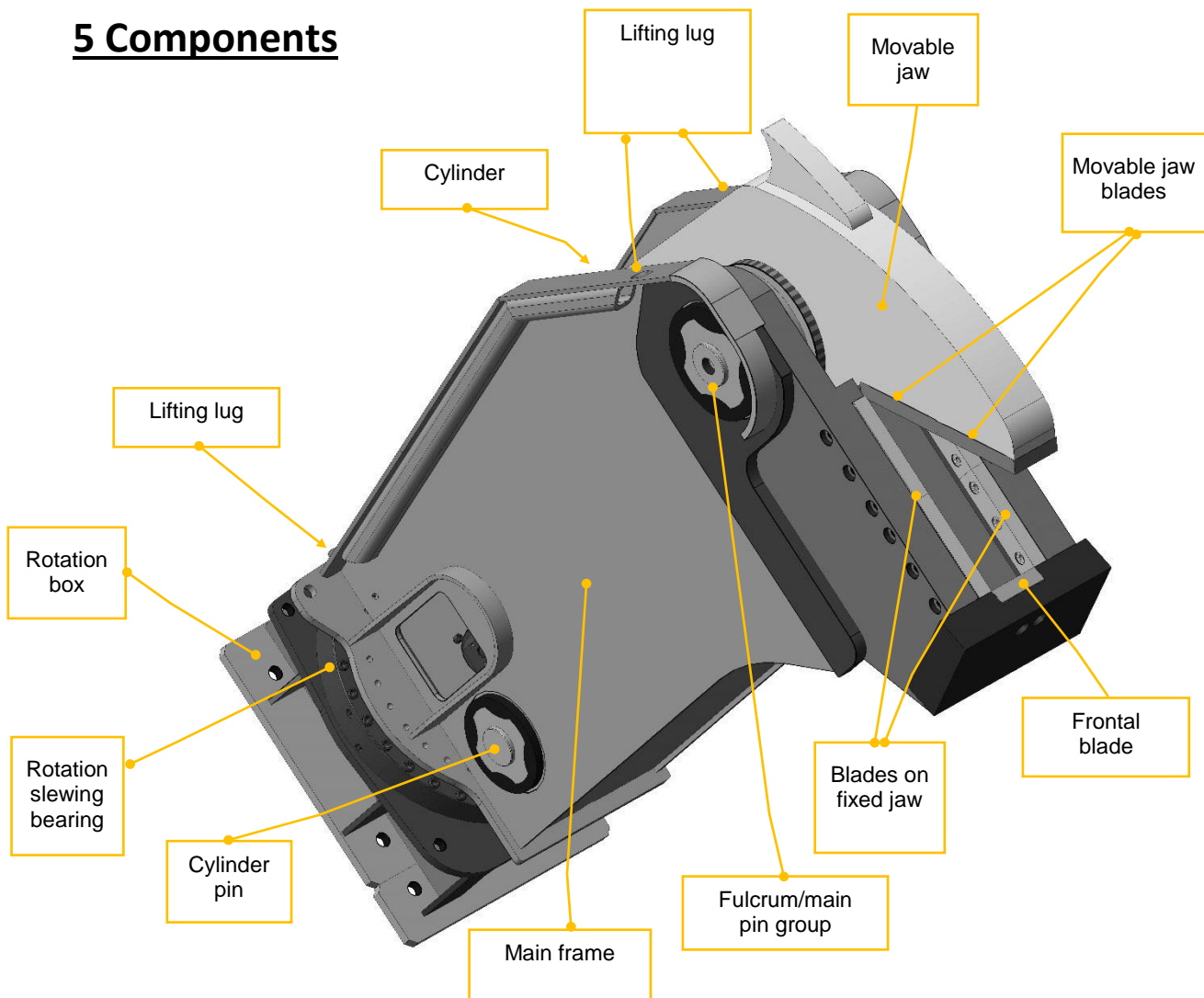

6 Transport



WARNING!

Danger of load falling!

The lifting and/or transport equipment, ropes or chains must have sufficient capacity for the weight of the tank shear.

Depending on its destination and the customer's requirements the tank shear is supplied on a pallet or in a crate. You must secure the individual parts before transport so that they cannot move.



down placed shear

6.1 Transport by crane

- Attach the crane ropes and/or chains to the tank shear 's transport lugs.



WARNING!

Danger due to suspended load!

There must not be any people within the range of the suspended load.

- Prevent any rotation using the anti-rotation locking pins
- Slowly lift the tank shear using the crane.
- Place the tank shear on wooden supports at the required location.



Anti-rotation locking pin

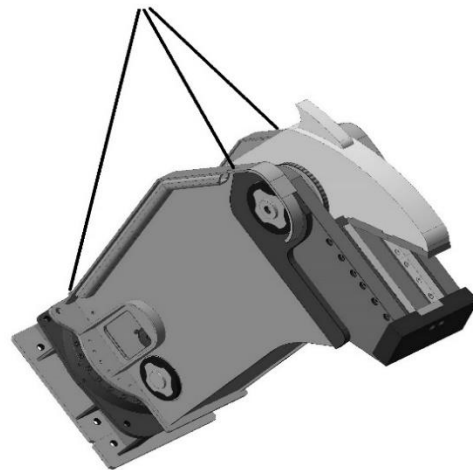

Transport by crane

6.2 Transport using a forklift truck



Danger due to load toppling over!

The tank shear must be placed on the forks so that it cannot topple over during transport.

- Move the forks under the tank shear so that it cannot topple over and fall off.
- Slowly lift the tank shear.



Danger due to moving load!

Secure the transport route so that nobody can be in the way.

- Transport the demolition cutter to the required location.
- Place the tank shear on wooden supports.

6.3 Transport using a lorry

When transporting the unpacked tank shear on a lorry, you have to ensure that the cutter is safely secured to the transport surface.

Danger due to load toppling over!

The tank shear must be placed on the transport surface so that it cannot topple over or slide away during transport.

- Attach ropes and/or chains to the tank shear's transport lugs.
- Secure the ropes and/or chains to the transport

6.4 Storage



Risk of burns!

Oil-carrying parts and hydraulic oil will be very hot after operating the tank shear.



Hydraulic oil running out!

Collect any hydraulic oil which runs out and dispose of it in accordance with the applicable statutory provisions to avoid environmental hazards.

- Collect any hydraulic oil which runs out when the hydraulic hoses are disconnected and dispose of it correctly.
- Close open pipes and hoses.
- Place the tank shear on wooden supports of sufficient size and stability.
- Store the cutter in a dry space, with a roof over it.

7 Installation

7.1 Agents/consumables



When handling oils and greases observe the safety instructions that apply to these products!

7.1.1 Mineral hydraulic oil

All hydraulic oil brands prescribed by the carrier manufacturer are also suitable for operating the tank shear. The oil should however comply with viscosity class HLP 32 or higher. In summer and in hot climates, oils of viscosity class HLP 68 or higher should be used. In all other respects the regulations of the carrier manufacturer are to be taken into consideration.

Optimum viscosity range = 30–60 cSt
Max. initial viscosity = 2000 cSt
Max. oil temperature (short term) = 80 °C

Please refer to *section 8.6* for low-temperature tank shear applications.

7.1.2 Non–mineral hydraulic oil

In order to protect the environment or on technical grounds, hydraulic oils are currently being used which are not classified as HLP mineral oils.

Before using hydraulic oils of this kind it is imperative to ask the carrier manufacturer whether operations with such fluids are possible.

Our tools are basically designed for use with mineral oils. Before using other fluid types which have been approved by the carrier manufacturer, always consult our Customer Support Department.

Following initial assembly and after any workshop repairs, our tools are subjected to a test run on a test bed powered **by mineral oil**.

Note:

When returning tools for repair, it is imperative that the name of the oil in use be indicated if you are using non–mineral oil.



CAUTION!

Never mix mineral and non–mineral hydraulic oils!

Even small traces of mineral oil mixed in with environmentally friendly fluids can result in damage to both hydraulic attachment and carrier.



CAUTION!

Non–mineral oil is no longer biodegradable if it is contaminated with mineral oil. Contaminated non–mineral oil must be disposed of as special waste in accordance with the applicable statutory regulations for environmental protection.

7.2 Preconditions



WARNING!

Danger of crushing!

The presence of people between the cutter arms is not allowed.

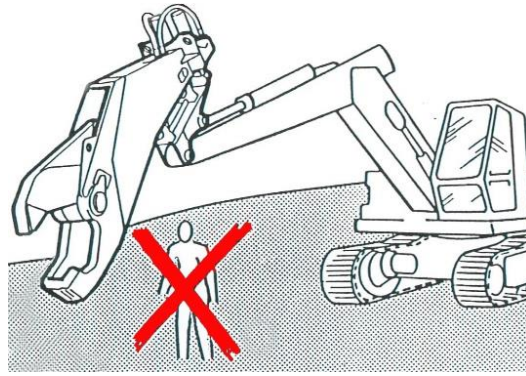

The screws must be designed for the loads to which the adapter is subjected. Only use the screws included in the delivery to attach the adapter.

Before mounting the tank shear on the excavator, you have to check that the load capacity of the excavator is sufficient. Otherwise the excavator may become unstable and fall over.

7.2.1 Conversion from hammering to cutter operation

The available hydraulic equipment can be checked by the Customer Service or the authorized dealer to determine to which extent additional equipment is required.

7.2.2 Checking a possibly existing cutter system

The existing cutter system (if available) can be checked by the Customer Service or the authorized dealer to ensure that it is free from problems, regardless of whether it is an Italmek or third-party system. Additional equipment may be required.

In all these cases the operational quality of the system is checked and it is checked that all specifications such as capacity and operating pressure comply with the target specifications.

7.3 Mechanical mounting aspects

7.3.1 Attaching the adapter

- Place the tank shear on wooden supports.
- All connections must be facing upwards to avoid their being damaged.
- Align the adapter (2) with the rotation mechanism plate (3).

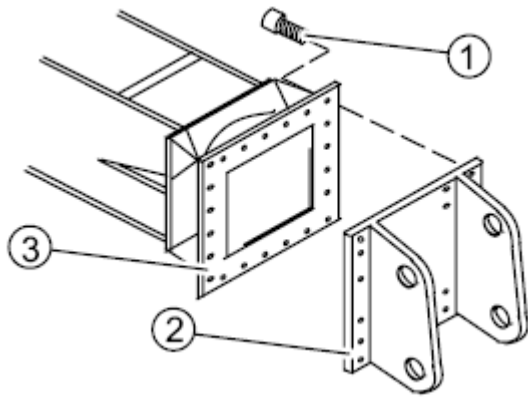

The screws must be designed for the loads to which the adapter is subjected. Only use the screws included in the delivery to attach the adapter.

- Use all screws (1) included in the supply to secure the adapter.

Note:

the illustration is a simplified picture showing only one screw.

- " Tighten all screws to the right torques as specified in *chapter 9.3.2*.

7.3.2 Attachment to the boom stick

- Place the tank shear on wooden supports within the reach of the carrier boom.
- All connections must be facing upwards to avoid their being damaged.
- Turn the tank shear with the mounted adapter so that the stick of the carrier boom can be moved into the adapter.
- Clean the interior connection surfaces using a rag.
- Clean the cutter pins and bushes.
- Agree with the assistant on clear hand signals to position the carrier boom.
- Move the carrier boom stick into the adapter.



Danger of body parts being crushed or cut off !

Never use your fingers to check whether the bores are flush.

- Insert the stick pin and check that the pin bores are clean.

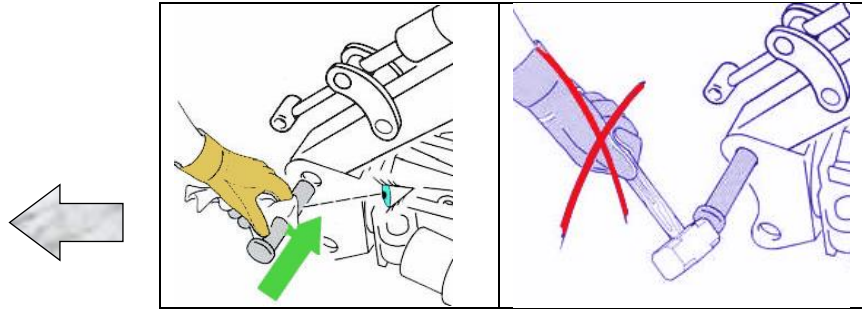

Carrier boom into adapter

It must be possible to insert the stick pin without effort.

- If you cannot easily insert the stick pin, you have to pull it out again.
- Keep moving the carrier boom until you can insert the stick pin without effort.
- Carefully move the carrier boom without load to enable you to insert the toggle pin.

The toggle pin bores on the boom must link up with the toggle pin bores on the adapter.

- Insert the toggle pin.
- Keep moving the carrier boom until you can insert the toggle pin without effort.
- Secure both toggle pins with the pin locking elements.

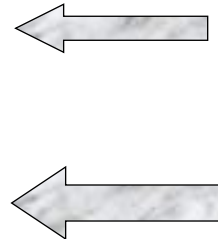

Pins insertion

7.4 Hydraulic mounting aspects

The high-pressure carrier/cutter connection hoses are not included in the supply.



WARNING!

Danger of crushing!

The presence of people between the cutter arms is not allowed.

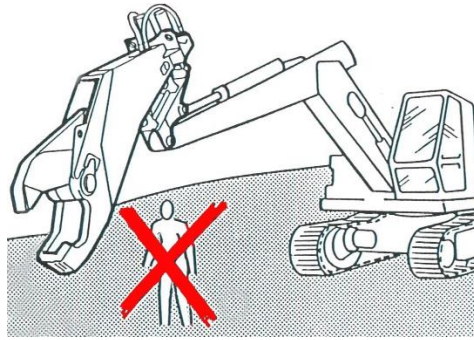

High-pressure hydraulic oil!

Check the nominal width of the hydraulic lines on existing hydraulic systems! All supply and return lines for the hydraulic oil must have a sufficient inside diameter and wall thickness. (see section [13](#)) Use only hoses/pipes which satisfy the following quality criteria:
 Hydraulic hoses according to standard SAE 517 or DIN 856 for the required pressure,
 Hydraulic pipes: seamless, cold drawn steel pipes to DIN:EN:10305

- Remove the seal caps from the connections between the carrier and the tank shear.
- Remove all dirt and dust from all hose ports and connections.
- Screw the hoses to the ports.
- Tighten the screw connections.

7.5 Disassembling

Note:

See the instructions for putting the system out of operation in section [8.7](#).



High-pressure hydraulic oil!

Depressurise the hydraulic system, otherwise there is a risk of injury due to hydraulic oil squirting out.

Depressurise the hydraulic system as follows:

- Switch off the engine but leave the ignition switched on.
- Repeatedly operate the switches for opening/closing/rotating the tank shear.



Risk of burns!

Hydraulic oil can be very hot after operation.

Make sure that nobody comes into contact with hot hydraulic oil.

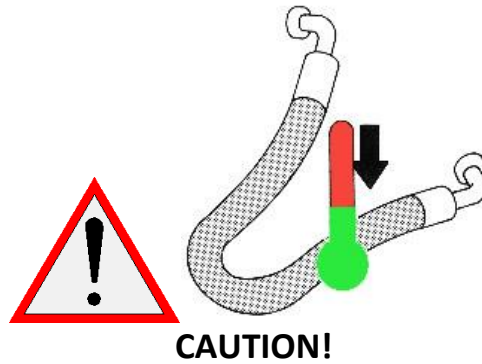

Hydraulic oil running out!

Collect any hydraulic oil which runs out and dispose of it in accordance with the applicable statutory provisions to avoid environmental hazards.

- Disconnect the hydraulic hose connections.
- Collect the hydraulic oil which runs out.
- Seal the connections with the seal caps.
- Remove the pin lock from the stick pin.
- Pull out the pin.
- Carefully move the carrier boom out of the cutter adapter.

8 Operating the tank shear

8.1 Starting up

The tank shear is ready for use as soon as it has been mounted.

Remove the anti-rotation locking pins before putting the shear into operation.



WARNING!

Danger of crushing!

The presence of people between the cutter arms is not allowed.



People must keep a **distance of not less than 20 meters** from machine at work

Danger zone



Risk of injury!

Stop the tank shear immediately if anyone enters the danger zone! During tank shear operation the danger zone is considerably greater than during the excavation operation – on account of fragments of stone and pieces of steel flying around – and for this reason, the danger zone must, depending on the type of material to be worked on, be enlarged correspondingly, or secured in a suitable manner through corresponding measures.

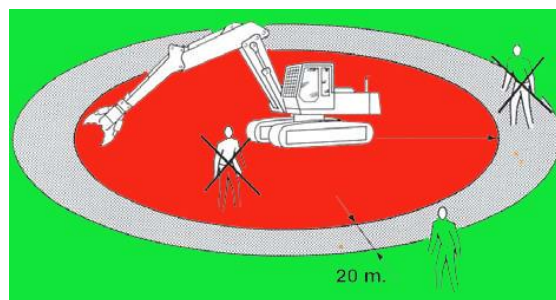

Risk of injury due to fragments of stone and pieces of steel flying around!

Close the front screen and, if available, the splinter guard on the driver's cab!

- **Excavator cabin must be protected by original or additional certified Rops and Fops protection !**



The tank shear should only be operated from the driver's cabin or using the remote control!

8.1.1 Switching the tank shear on/off from the carrier

The installation of a genuine conversion kit in the carrier’s hydraulic system allows the tank shear to be powered using the carrier hydraulics. All functions for normal excavator operations remain intact. The tank shear is switched on/off via electrical signals.

- When leaving the driver’s cab, the safety switch for these electrical signals must be set to the "OFF" position so as to reliably prevent any unintended start-up of the tank shear





Both the carrier and the tank shear can be operated by remote control. For further details please contact the carrier manufacturer or our Customer Support.

8.1.2 Frontal position

Demolition operations must be executed with carrier boom in frontal position in line with the undercarriage, better if opposite to the traction wheels. Absolutely not with carrier boom in perpendicular position respect the carrier undercarriage.



Working with carrier boom in perpendicular position respect carrier undercarriage will drastically reduce the stability of demolition machine and it is also possible the overturning of carrier.

			
correct position	wrong position VERY DANGEROUS !	correct position	risk position WORK ONLY ON THE GROUND !

working position



Do not make any sudden movements when with carrier arm when the tank shear is mounted.



8.1.3 Functional test

- Start the carrier.
- Slowly pressurize the hydraulic circuit to avoid shocks.
- Increase the pressure until the maximum operating pressure specified on the nameplate of the tank shear is reached.
- Using the carrier boom functions, raise the tank shear until it is freely suspended.

First functional test: **opening and closing**

- Operate the switch in the leg-space area of the cab to open and close the cutter jaws.
- Open the cutter one quarter with the engine idling and close it again.
- Open the cutter halfway and finally three quarters, closing it again in between.
- Repeat this procedure 5–6 times to make sure that there is no leakage in the hydraulic system.

Second functional test: **Rotate the cutter to the left and to the right**

The cutter rotation can be tested either by using the carrier function” **rotate cutter**” or by using a new additional system.

8.2 Using the tank shear



Risk of injury!

Stop the tank shear immediately if anyone enters the danger zone! During tank shear operation the danger zone is considerably greater than during the excavation operation – on account of fragments of stone and pieces of steel flying around – and for this reason, the danger zone must, depending on the type of material to be worked on, be enlarged correspondingly, or secured in a suitable manner through corresponding measures.

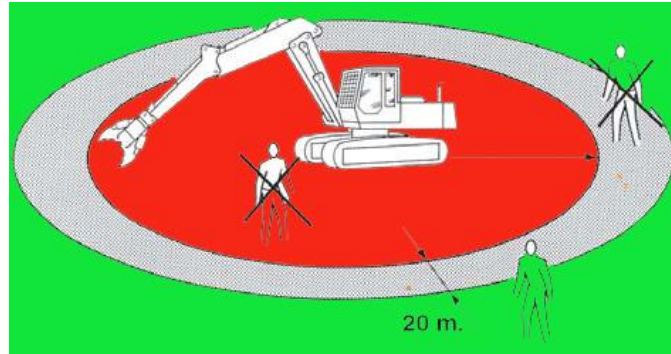

8.3 Instructions on the correct use of the tank shear



Operating the tank shear with the boom/stick cylinders fully extended or retracted must be avoided at all costs.

- These end positions are equipped with damping functions; continuous operation at full extension/retraction can result in damage to the hydraulic cylinders.
- When the boom is fully extended in elevated position (high over the cabin) to work with cylinder fully extended or fully retracted **is dangerous because material can fall down over the operator cabin !**

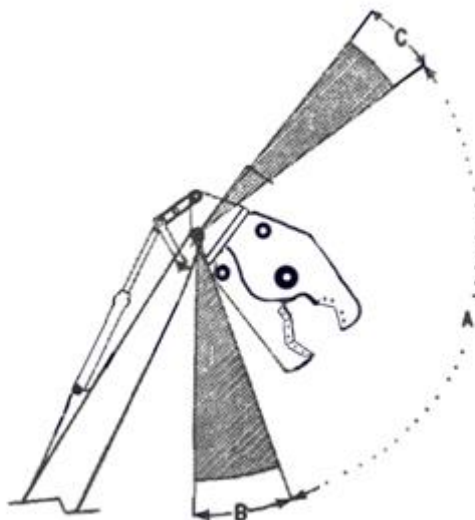

A – working area	B – dangerous area	C – dangerous area
------------------	--------------------	--------------------

Working area

During the demolition work in height the driver is subjected to the risk of falling material from the top but also to bounce; the excavator cabin must be equipped with certified FOPS protection.



When working on floors/roofs, ensure that they are strong enough to bear the weight of the carrier.

Danger of collapse!



Never lift or transport loads with the tank shear!



CAUTION!

Never hack or pound with the tank shear since this will cause serious damage to the tank shear.

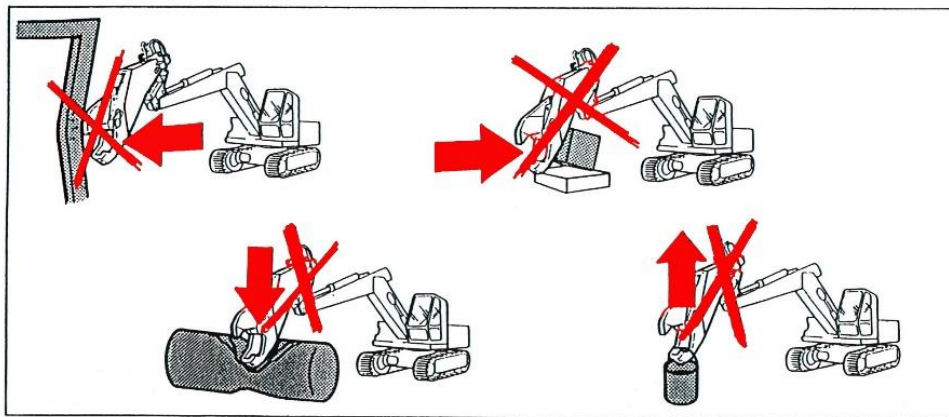

CAUTION!

Never pull at girders or supports with the tank shear! This will damage both the tank shear and the adapter. The carrier may also become unstable and fall over.



CAUTION!

Do not come nearer than 10 meters from the overhead voltage cables with any part of the machine.

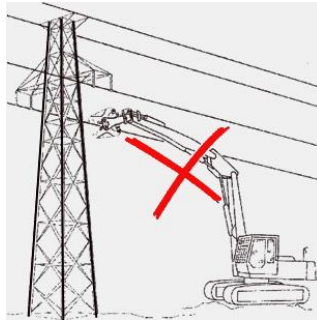

8.4 Underwater use

The tank shear must never be used underwater! A dedicated one must be produced on customer request.

8.5 Working in high ambient temperature

The temperature of the hydraulic oil must be monitored to ensure it does not exceed 80 °C. If higher temperatures are measured in the tank, the system and the pressure-relief valve have to be checked. Only use hydraulic oils of sufficient viscosity. In summer and in tropical climates, the minimum requirement is a hydraulic oil of type HLP 68.

8.6 Working in low ambient temperature

To work in low ambient temperature requires to observe some important precautions before starting the use of tank shear.

Jaws and blades must be warmed up before starting work in order that metals will be brought to a temperature higher than zero degrees (0° C).

This can be done opening and closing jaw for some minutes or starting to cut small dimensions of pieces for some minutes before putting shear under effort cutting big pieces or harder material in general.

With lower temperature the warm up can be done also with the help of fire/flame.

When ambient temperature is below minus 20 degrees (-20° C) the working conditions are very risky, before using the shear please contact the producer for having the official authorization to the use. Tank shear cannot be used in any way before making the warm up by fire or flame.

In the majority of cases, carriers and attachments are kept in protected or even heated areas when not in use. At this temperature problem of hydraulic oil temperature adds to problem on metals. However, if the carrier and the tank shear are left out in the open, the carrier and all equipment must be warmed up before the demolition cutter can be started up.

At temperatures below minus 20°C, the carrier must be warmed up prior to use in the way described by the excavator manufacturer.

The excavator manufacturer's regulations must be observed in full. Ensure that the hydraulic oil in the carrier is at least at 0°C.

As excavator, also the tank shear cannot be started up until the oil temperature is 0°C or higher. Observe the excavator manufacturer's safety instructions!

Note:

During operations, leave the excavator engine and pumps running even during breaks. The tank shear and excavator will not operate to full capacity until the oil temperature has reached at least 60 °C.



Feeding hot hydraulic oil to an extremely cold tank shear will cause internal stresses in the unit resulting in its failure. Operation without allowing the hydraulic oil to heat up first will result in damage.

8.7 Putting the system out of operation

Proceed as follows at the end of your work shift or before storing the tank shear:

- Fully open the cutter while the engine is running.

The piston rod will be fully retracted.

- Rotate the cutter so that you can insert the anti-rotation locking pins.
- Fit the anti-rotation pin and lock it with the nut.
- Secure the cutter against accidental opening of the cutter jaws.
- Fully retract the cutter towards the excavator.
- Place the front of the tank shear on the floor.
- Remove the pin lock from the toggle pin.
- Pull out the toggle pin.
- Move the jaw and place the cutter on wooden supports.
- Put the excavator in neutral gear and switch off the engine.

Note:

To remove the tank shear, please observe the instructions in [section 7.5](#).

9 Maintenance

9.1 General information

In order to obtain the best performance from the tank shear, maintenance work should be carried out by the operator at the prescribed intervals.

The maintenance work listed here must be carried out by a qualified carrier driver at the prescribed intervals.

The carrier driver must be familiar with the use of a torque wrench and **wear suitable safety protection garments** (gloves, glasses, helmet, safety shoes).

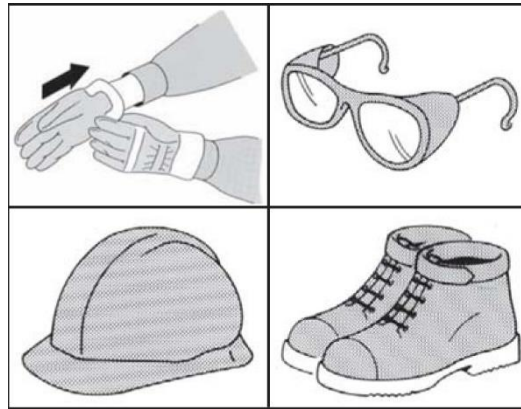

WARNING!

Danger of crushing!

The presence of people between the cutter arms is not allowed.

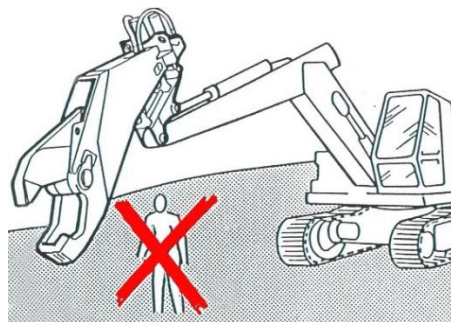

WARNING!

High-pressure hydraulic oil!

Depressurise the hydraulic system, otherwise there is a risk of injury due to hydraulic oil squirting out.



WARNING!

High-pressure hydraulic oil!

Never use your fingers to check the hydraulic system for leaks. There is a risk of injury due to hydraulic oil squirting out and penetrating into your skin. Use some paper or board to check the system for leaks.

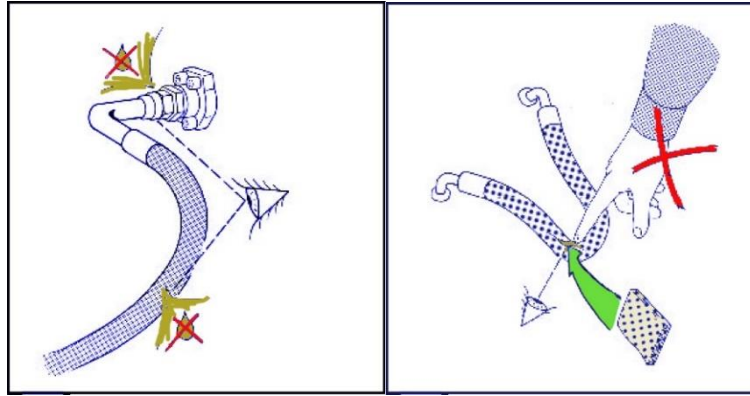

Depressurise the hydraulic system as follows:

- Depressurise the hydraulic system as follows:
 - Switch off the engine but leave the ignition switched on.
 - Repeatedly operate the switches for opening/closing/rotating the tank shear.
 - Disconnect the hydraulic hoses from the tank shear.
- Secure the motor against accidental or unauthorized operation.

9.2 Maintenance schedule

9.2.1 Maintenance after the first 10 operating hours

- Tighten all screws on the rotation mechanism to the right torques as specified in *section 9.3.2*.

9.2.2 Daily maintenance (at least every 10 operating hours)



The screws can only be tightened to torque once.

If the screws come loose, you should fit new screws and tighten them to the torques indicated.

- Check all screws on the rotation mechanism to make sure that they are tight.
- If a screw has come loose, you should fit a new screw and tighten it to the torque indicated.
- Tighten all screws on the covers.
- Lubricate all lubricating points and the live ring, as described in *section 9.3.1*.
- Replace broken lubricating nipples.
- Check the front and rear cutter blade clearance values. They must comply with the values listed in *section 9.3.3*.

Daily visual checks:

- Check the tank shear and adapter for cracks.
- Check the cylinders, manifolds, hydraulic motor, hydraulic hoses and connections for wear.
- Check the blades for wear.

Replace worn blades in time.

- Check the hard facing on the cutter jaws for wear.
- Replace the hard facing if it is found to be worn.

Proceed as described in [section 9.3.6](#).

9.2.3 Weekly maintenance (at least every 50 operating hours)

- Reverse the blades. This ensures uniform blade wear. Proceed as indicated in [section 9.3.5](#).



The screws can only be tightened to torque once.

If the screws come loose, you should fit new screws and tighten them to the torques indicated.

- Fit new screws to secure the blades.
- Tighten the screws to the right torques as specified in [section 9.3.2](#).
- Check that all screw connections are tight.
- Replace screws that have come loose and tighten the new screws to the required torque.

9.2.4 Monthly maintenance

- Check the oil level in the rotation mechanism gears.

9.2.5 Yearly maintenance (at least every 1500 operating hours)

- Replace the cylinder seals kit after 1500 operating hours



Operating the tank shear with worn-out seals will decrease shear performance and may cause internal damage to the cylinder. Please note that cylinder seals life is highly dependent on the care taken to properly maintain the hydraulic fluid.

9.3 Maintenance activities

The maintenance work listed here must be carried out by a qualified carrier driver at the prescribed intervals. The carrier driver must be familiar with the use of a torque wrench.

Note:

Please consult our Customer Support Department for major repairs to the rotation mechanism (replacing the pinion, ring, hydraulic motor etc.).

9.3.1 Lubrication

Lubricate the lubrication points on the tank shear using a grease gun

- The lubrication points on the tank shear must be greased daily, using the grease gun.
- Apply enough strokes to make the grease protrude from the lubrication point a little



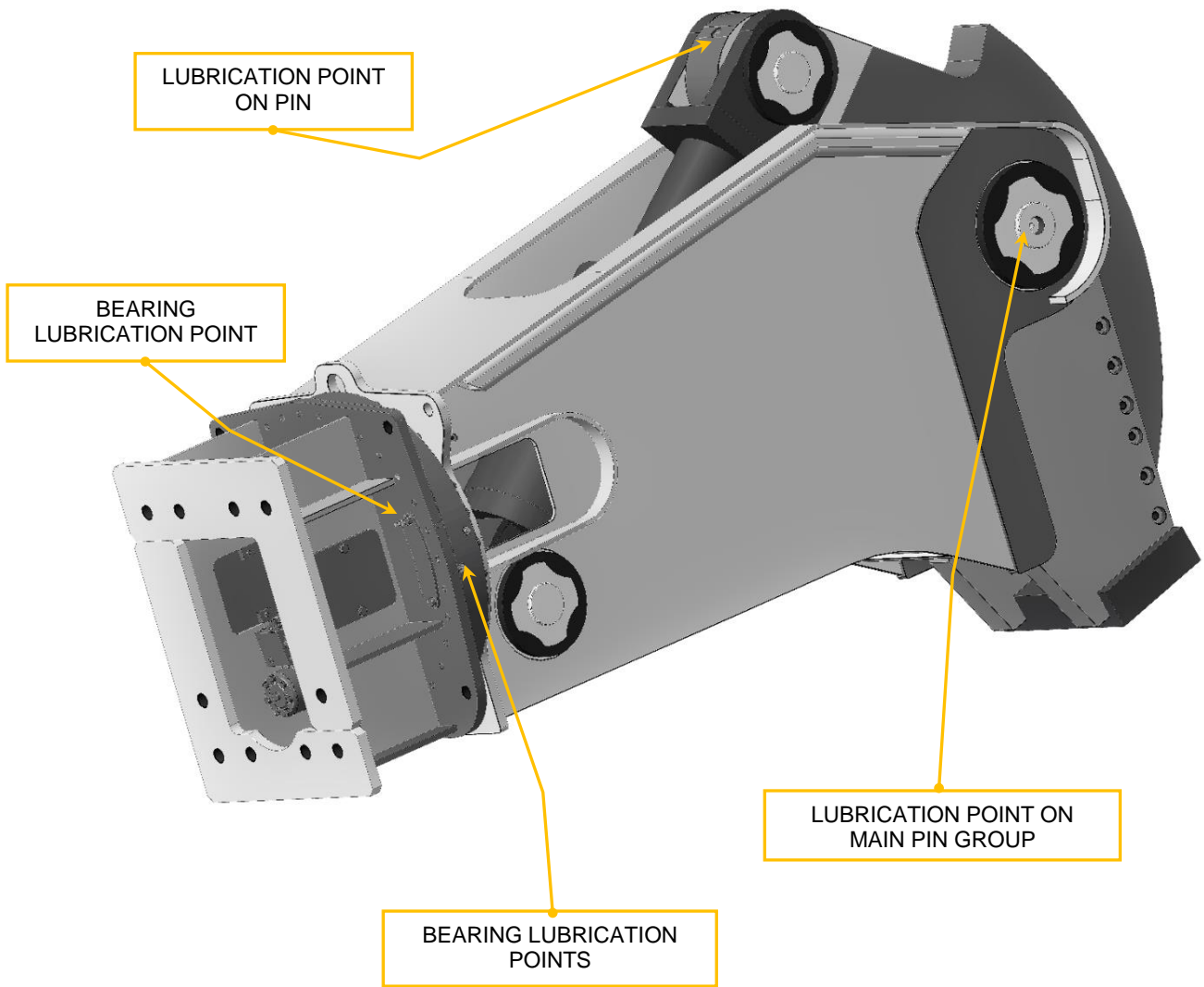

9.3.2 Torques for screw connections

- Tighten all screws to the required torques.

Resistance class DIN/ISO 898				
8.8			10.9	
Carico limite di snervamento $R_{p0.2}$ in N/mm ²				
640 per < M16 660 per > M16			940	
Screw diameter	Forza di tensionamento N	Coppia di serraggio e montaggio Nm	Forza di tensionamento N	Coppia di serraggio e montaggio N
M12	38500	78	56000	117
M14	53000	126	77000	184
M16	72000	193	106000	279
M18	91000	270	129000	387
M20	117000	387	166000	558
M22	146000	522	208000	747
M24	168000	666	239000	954
M27	221000	990	315000	1395
M30	270000	1350	385000	1890

9.3.3 Checking the blade clearance

Check the cutter blades for the correct clearance. If the clearance between the cutter jaw and the cutter casing is too much, thin material may get stuck.

- Lower the cutter jaw until the cutting edge rests against the corresponding cutter casing edge.
- Use a feeler gauge to check the blade clearance.

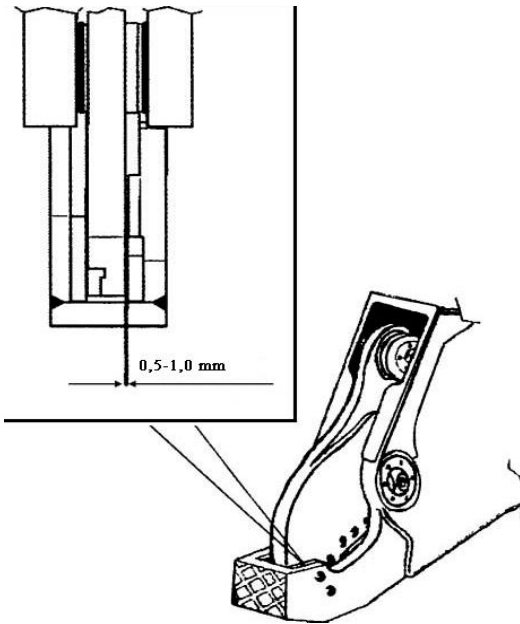

The blade clearance must not exceed 0.5–1,0 mm.

For optimum tank shear operation, you should also measure the clearance behind the cutting gap.

- Lower the cutter jaw further until its total edge rests against the corresponding cutter casing edge.
- Use a feeler gauge to check the rear clearance.

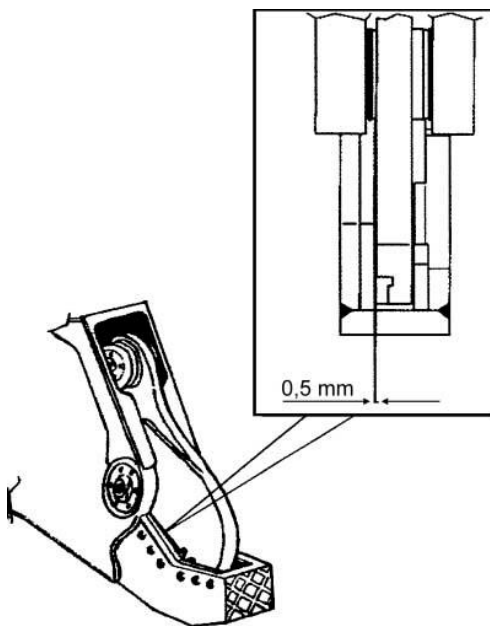

The rear clearance must not exceed 0.5 mm.

9.3.4 Correcting the blade clearance

If the blade clearance exceeds the target values you can correct it by fitting shims behind the stationary lower cutter jaw.



CAUTION!

You can fit more shims provided that the total clearance does not exceed 3.5:mm. In this event you will have to replace the worn blade.



WARNING!

Risk of injury due to crushing or cuts!

When working on the blades there is a risk of parts of your body being cut or crushed if the cutter suddenly closes. Secure the moving upper cutter jaw with a block of wood.

- Open the cutter all the way and secure the moving upper cutter jaw with a wooden block to prevent it snapping closed.
- Loosen the screws of the lower blades.
- Slide shims between the blade and the blade seat.
- Tighten all blade screws to the right torques as specified in [section 9.3.2](#).
- Remove the wooden block and carefully close the cutter.
- Check the blade clearance again.

9.3.5 Reversing and replacing blades



CAUTION!

Missing blades must be replaced immediately.

Working without blades causes serious damage to the blade seat on the cutter jaw. Repairing the blade seat is highly time-consuming and expensive.

- A blade must be replaced if its cutting edge is damaged.



CAUTION!

A blade should only be reversed if its contact face is undamaged. When fitting new blades, always use new fastening screws.

- Reverse the blades every 80 operating hours to ensure uniform wear.
- Remove the blade screws.
- Reverse the blade or fit a new blade.
- Use new screws to fit the blades.
- Tighten the screws to the right torques as specified in *section 9.3.2*.

9.3.6 Hard facing for cutter jaws

When the hard facing in the cutter jaws becomes worn, it can be renewed by a qualified welding specialist.



WARNING!

Danger due to toxic smokes !

Evaporated paint ingredients can produce toxic smokes during welding. Remove all paint residues from the hard facing.



WARNING!

Risk of fire!

There is a risk of oil and other flammable products igniting during welding. Remove all oil and all other flammable products from the working area to prevent them igniting.



DANGER!

Risk of electric shock!

Welding with a faulty earth connection can result in an electric shock. Connect the welder's earth pole to the part to be welded, in the immediate vicinity of the welding area.

The earth pole must be connected so that the current cannot flow through the hinges and the cutter cylinder.



CAUTION!

If the cutter is mounted on the carrier during welding, the carrier instructions must be observed to prevent damage to the battery or the electric system of the carrier.

- Carefully clean the application area.



CAUTION!

Regularly check the temperature. The cutter may be damaged if the preheating temperature is exceeded.

- Preheat a large part around the application area to 100° C.
- Reconstruct worn parts with thread according to the standard AWS A.5.28 ER 80 S-X or with electrode according to the standard AWS A 5.5 E 80-X.
- Once reconstructed, smear and bring with hard facing thread.

Note:

do not apply more than one layers of hard facing thread.

10 Troubleshooting

We have listed a number of possible problems, causes and remedies in this section.

10.1 The tank shear does not work

Cause	Remedy	By
Check valve in line O or C closed (O=opening C=closing)	Open the check valve	Carrier driver
Defective couplings blocking O / C lines	Replace defective coupling parts	Workshop
Electrical equipment for cutter hydraulics defective	Check the electrical equipment and repair as necessary	Workshop
Rocker switch defective	Check the rocker switch and re_ pair as necessary	Workshop
Magnet on switch-on valve defective	Replace the magnet	Workshop

10.2 Shearing capacity tank shear insufficient

Cause	Remedy	By
Connections for lines O and C are wrong	Connect up lines O and C correctly Only in case of different pressure settings of lines O and C , i.e. existing system is suitable for tank shear operation	Carrier driver
Operating pressure too low	Correct the operating pressure	Workshop or Customer Support

10.3 The tank shear does not cut

Cause	Remedy	By
Blades worn/broken. Excessive brake clearance	Check blades, if necessary adjust or replace them	Workshop

10.4 The tank shear cannot be rotated

Cause	Remedy	By
Rotation motor/gear unit/trans_ mission defective	Replace the defective parts	Customer Support

10.5 Operating temperature too high

Cause	Remedy	By
Pump delivery too high _ excess oil squirts out via pressure relief valve	Correct carrier engine speed. Correct pump pilot system if available	Carrier driver or Customer Support
Pressure relief valve defective	Fit new pressure relief cartridge	Customer Support
Oil level in tank too low	Top up oil	Carrier driver or Workshop

10.6 Oil leaks from hydraulic ports

Cause	Remedy	By
Cap nuts loose	Tighten cap nuts	Carrier driver

10.7 Insufficient lubrication

Cause	Remedy	By
Intervals between lubrication too long	Lubricate more frequently	Carrier driver

11 Disposal



CAUTION!

Dispose of the tank shear and the hydraulic oil in accordance with the applicable statutory provisions on environmental protection.

- Put the tank shear out of operation and disassemble it as described in sections [8.7](#) and [7.5](#).
- Dispose of the tank shear in line with all applicable regulations or consult an authorised and specialised recycling company.

12 Technical specifications

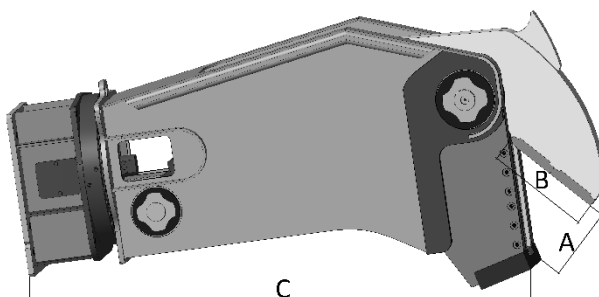

(All dimensions and weights are indicatives)

		ATC20	ATC25	ATC40	ATC65
Weight	kg	2200	2700	3700	6500
Excavator weight					
boom position	ton	12-20	16-25	22-32	30-50
bucket position	ton	20-28	24-35	32-47	65-85
Dimensions					
A opening	mm	330	355	380	400
B depth	mm	450	500	580	650
C length	mm	2150	2750	2650	3000
Working pressure	bar	340	350	350	350
Oil flow	l/m	150/250	200/300	250/350	350/450
Rotation pressure	bar	110	110	110	110
Rotation flow	l/m	30	30	30	30
Cutting capacity	mm	20	25	35	40

Weights don't include standard adapter

Technical specifications are subject to change without notice.

13 Guarantee

Conditions of guarantee for ACDE products:

- Every equipment produced is guaranteed for a period of twelve (12) months from the date of delivery;
- Any claims or complains must be sent to ACDE within and no later than eight days from receipt of the goods. Returned goods shall only be accepted if previously authorised by us and sent, carriage paid, to our factory.
- During the course of the guarantee, ACDE assures the substitution or the repair, at option of ACDE, free of charge of any accessory, component or part that, under the noobjectionable view of its technicians, shows defects to the material and/or the workmanship;
- The inspection of accessories, components, or parts of equipment is to be carried out solely at the ACDE premises.
- All items subject to guarantee must reach the ACDE under “free port”;
- Any investigations in locus and labour costs relevant to the substitution of the defective items are payable by the client;
- It is never possible to ask to ACDE to pay for transports or cost of impossibility of using the equipment, as well as penalty for work not done, ensuing loss of earnings, replacement machinery, commercial damage, etc.
- Not covered by the guarantee are all those components and accessories subject to normal wear and tear through regular use of the equipment.
- Not covered by the guarantee are damage caused by use of ACDE equipment when in an apparently or initially faulty state.

The guarantee is no longer valid under the following conditions:

- Lack of observation, even if minimal, of the instructions contained in the “Use and Maintenance manual” supplied with the equipment;
- Improper use of the equipment;
- Wrong installation;
- Use of the equipment by untrained personnel;
- Unauthorised interventions and modifications;
- Use of non original spare parts;
- Use of spare parts not in compliance with the type of equipment supplied;
- Atmospheric and climactic conditions or exceptional events unforeseen during the planning stages. Use of the product at temperatures below - 20 ° C and above + 68 °;
- Payment terms have not been met.

ACDE refuses to admit any form of guarantee not provided for expressly herein. No agent, dealer or representative is authorised to offer anything other than the above guarantees in ACDE' name.

When submitting a guarantee claim, it is necessary to receive photographic documentation about CE plate, serial number stamped on chassis and defective parts. Moreover, always remember to quote:

- Model
- Serial no.
- Date of delivery
- Name of dealer
- Name of owner

ACDE EUROPE BV
Frans Halsstraat 5
6901 DC Zevenaar
The Netherlands

Phone +31 316 267291
E-mail info@acde-europe.com
Invoices facturen@acde-europe.com
Website www.acde-europe.com
Traderegister 09184314 Arnhem

Banker ABN-AMRO Arnhem
Accountnr. 0460543334
IBAN NL45 ABNA 0460543334
BIC ABNANL2A
VAT No./EORI NL802344744B01