

# Machine for Industrial Applications **A 934 C HD**

Litronic<sup>®</sup> High Rise

Operating Weight: 45,500 – 46,400 kg  
Engine Output: 150 kW / 204 HP



# LIEBHERR

# Technical Data



## Engine

Rating per ISO 9249	150 kW (204 HP) at 1,800 RPM
Model	Liebherr D 934 L according to level IIIA/Tier 3
Type	4 cylinder in-line
Bore/Stroke	122/150 mm
Displacement	7.0 l
Engine operation	4-stroke diesel unit pump system turbo-charged and after-cooled reduced emissions
Cooling	water-cooled and integrated motor oil cooler
Air cleaner	dry-type air cleaner with pre-cleaner, primary and safety elements, automatic dust discharge
Fuel tank	580 l
Standard	sensor controlled engine idling
Electrical system	
Voltage	24 V
Batteries	2 x 170 Ah/12 V
Starter	24 V/6.6 kW
Alternator	three phase current 28 V/80 A
Option	Liebherr particle filter



## Hydraulic System

Hydraulic pump for attachment and travel drive	two Liebherr variable flow, swash plate pumps
Max. flow	2 x 245 l/min.
Max. pressure	350 bar
Pump regulation	electro-hydraulic with electronic engine speed sensing regulation, pressure compensation, flow compensation, automatic oil flow optimizer
Hydraulic pump for swing drive	reversible, variable flow, swash plate pump, closed-loop circuit
Max. flow	148 l/min.
Max. pressure	380 bar
Hydraulic tank	350 l
Hydraulic system	590 l
Hydraulic oil filter	2 full flow filters in return line with integrated fine filter area (5 µm)
Hydraulic oil cooler	compact cooler, consisting of a water cooler, sandwiched with hydraulic oil cooler, fuel cooler and after-cooler cores and hydrostatically driven fan
MODE selection	adjustment of machine performance and the hydraulics via a mode selector to match application
ECO	for especially economical and environmentally friendly operation
POWER	for maximum digging power and heavy duty jobs
LIFT	for lifting
FINE	for precision work and lifting through very sensitive movements
RPM adjustment	stepless adjustment of engine output via the rpm at each selected mode
Tool Control (Option)	ten preadjustable pump flows and pressures for add on tools



## Hydraulic Controls

Power distribution	via control valves in single block with integrated safety valves
Flow summation	to boom and stick
Closed-loop circuit	for uppercarriage swing drive
Servo circuit	
Attachment and swing	proportional via joystick levers
Travel	proportional via foot pedal
Additional functions	via foot pedals or joystick push buttons



## Swing Drive

Drive by	Liebherr swash plate motor with integrated brake valves
Transmission	Liebherr compact planetary reduction gear
Swing ring	Liebherr, sealed single race ball bearing swing ring, internal teeth
Swing speed	0 – 4.5 RPM stepless
Swing torque	84 kNm
Holding brake	wet multi-disc (spring applied, pressure released), pedal controlled positioning brake



## Operator's Cab

Cab	resiliently mounted, sound insulated, tinted windows, front window stores overhead, door with sliding window
Operator's seat	fully adjustable, shockabsorbing suspension, adjustable to operator's weight and size, 6-way adjustable Liebherr seat
Joysticks	integrated into adjustable consoles
Monitoring	menu driven query of current operating conditions via the LCD display. Automatic monitoring, display, warning (acoustical and optical signal) and saving machine data, for example, engine overheating, low engine oil pressure or low hydraulic oil level
Air conditioning	standard air conditioning, combined cooler/heater, additional dust filter in fresh air/recirculated
Noise emission	
ISO 6396	$L_{pA}$ (inside cab) = 74 dB(A)
2000/14/EC	$L_{WA}$ (surround noise) = 104 dB(A)



## Undercarriage

Drive	Liebherr variable flow swashplate motor with automatic brake valves
Transmission	oversized two speed power shift transmission with additional creeper speeds
Travel speed	0 – 2.5 km/h (creeper speed) 0 – 5.0 km/h (cross country) 0 – 9.0 km/h (creeper speed road) 0 – 18.0 km/h (road travel)
Axles	70 t excavator axles; automatic or operator controlled front axle oscillation lock
Service and holding brakes	multiple wet discs
Parking brake	multiple wet discs (spring applied – pressure released)
Stabilization	4-point outriggers with suspended rocker arm supports



## Attachment

Type	high-strength steel plates at highly-stressed points for the toughest requirements. Complex and stable mountings of attachment and cylinders. Unrivalled strength, even at high loads
Hydraulic cylinders	Liebherr cylinders with special seal system. Shock absorption
Pivots	sealed, low maintenance
Lubrication	Liebherr semi-automatic central lubrication system

# Dimensions

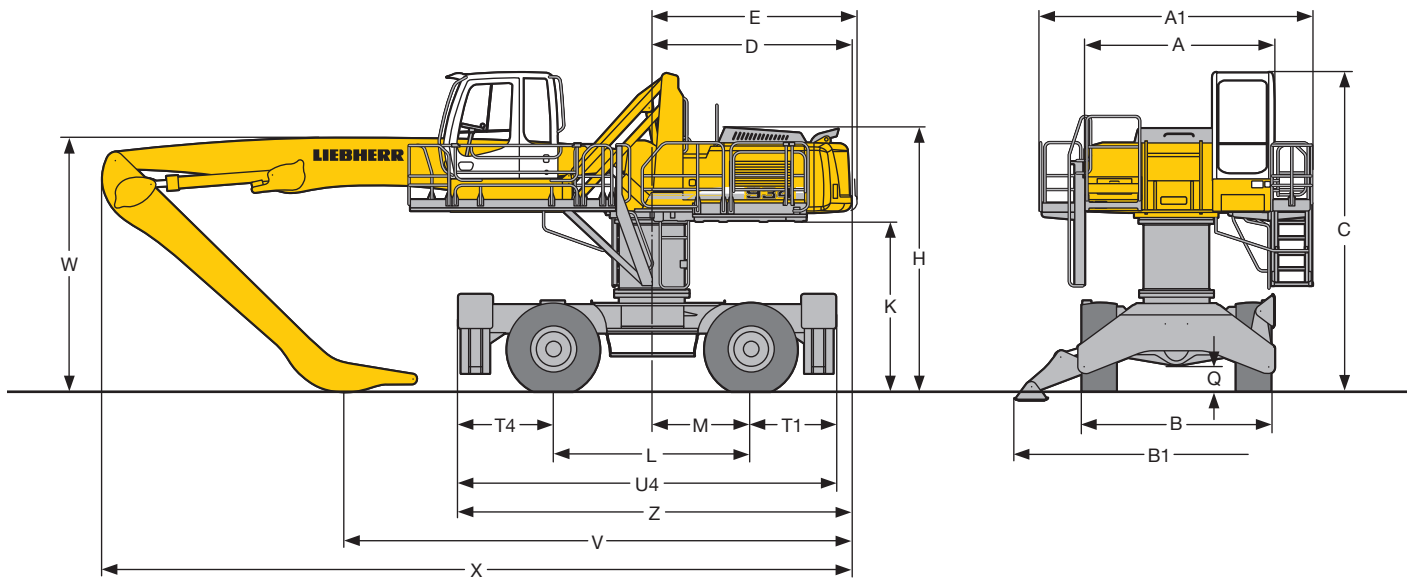

	mm
A	3,075
A1	4,470
B	3,200
B1	5,250
C	5,185
D	3,235
E	3,235
H	4,290
K	2,770
L	3,200
M	1,600
Q	430
T1	1,385
T4	1,535
U4	6,120
Z	6,295

E = Tail radius

**Tires 16.00-25**

<b>Industrial-Type Gooseneck Boom 8,60 m and Industrial Stick</b>			
	m	6.00	7.50
V	mm	7,650	6,850
W	mm	4,750	5,450
X	mm	12,350	12,450

<b>Industrial-Type Straight Boom 8.60 m and Industrial Stick</b>			
	m	6.00	7.50
V	mm	8,250	6,750
W	mm	4,300	4,600
X	mm	12,350	12,350

<b>Industrial-Type Straight Boom 9.60 m and Industrial Stick</b>			
	m	7.50	9.00
V	mm	7,500	6,500
W	mm	4,300	5,600
X	mm	13,350	13,250

Dimensions are with attachment over steering axle



# Industrial Attachment

with Industrial-Type Gooseneck Boom 8.60 m

## Attachment Envelope

Kinematic variant 3D

- 1 with industrial stick 6.00 m
- 2 with industrial stick 7.50 m
- 3 with industrial stick 6.00 m and grapple model 70 C
- 4 with industrial stick 7.50 m and grapple model 70 C

## Operating Weight

Operating weight includes basic machine A 934 C HD Litronic High Rise with 4 point outriggers, hydraulic cab elevation, 4 solid tires and industrial application with industrial-type gooseneck boom 8.60 m.

with grapple model 70 C/0.80 m <sup>3</sup> semi-closed tines	Weight
industrial stick 6.00 m	45,900 kg
industrial stick 7.50 m	46,200 kg

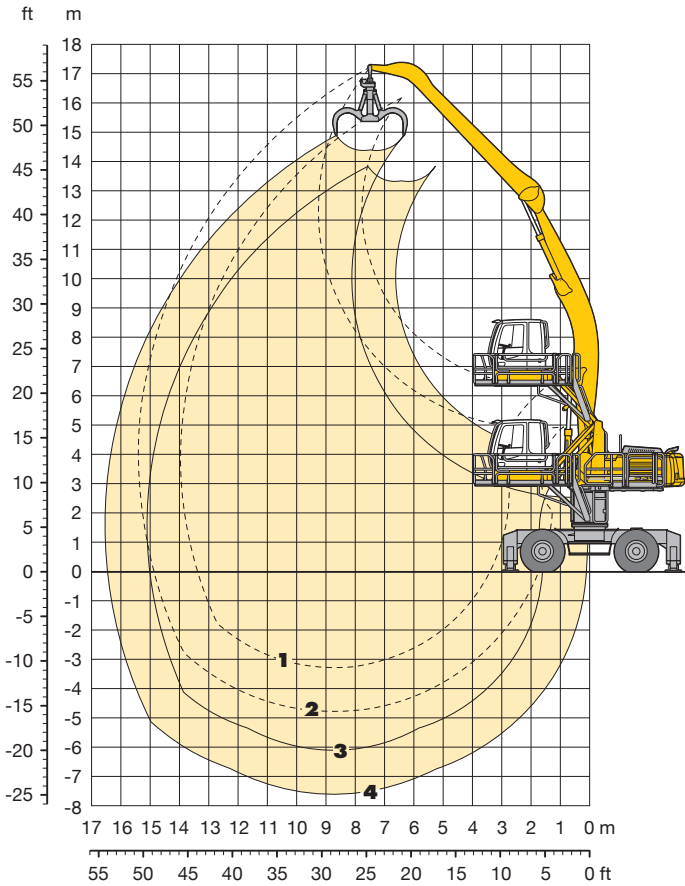

## VarioLiftPlus

**VarioLiftPlus:** Variable boom mounting positions for optimized lift capacities

with a **different** working range

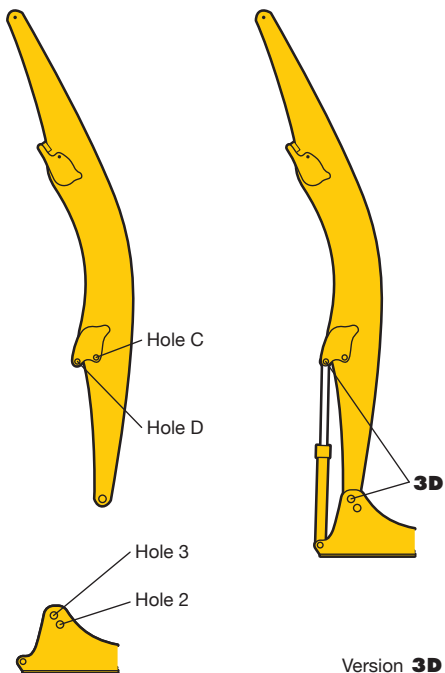

Version 3D

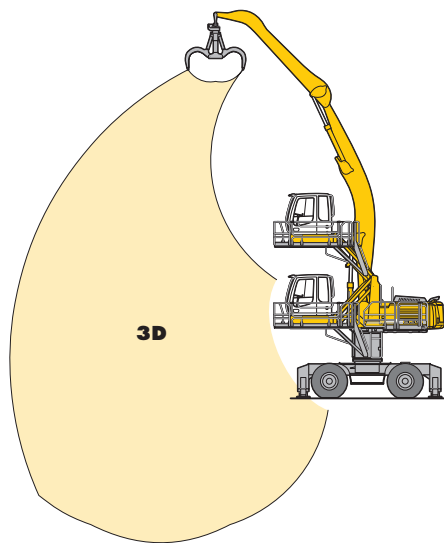

**Kinematic Variant 3D:**

Increased lift capacities below ground level and when working at large outreach

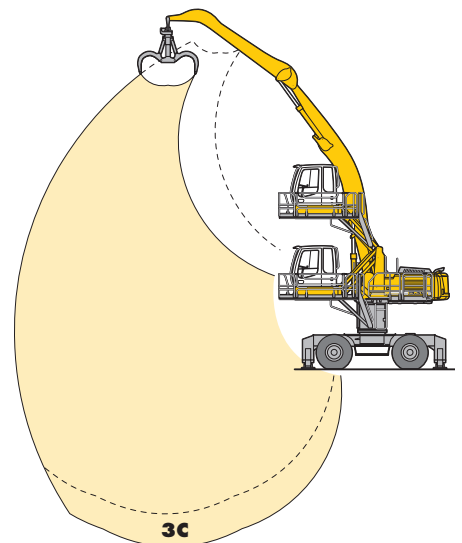

**Kinematic Variant 3C:**

Altered range curve with additional reach depth, e.g. for unloading from ships

# Lift Capacities

with Industrial-Type Gooseneck Boom 8.60 m (Kinematic Variant 3D)

## Industrial Stick 6.00 m

m	Undercarriage	3.0 m		4.5 m		6.0 m		7.5 m		9.0 m		10.5 m		12.0 m		13.5 m		15.0 m		16.5 m		18.0 m		m				
21.0	4 pt. outriggers down																											
19.5	4 pt. outriggers down																											
18.0	4 pt. outriggers down																											
16.5	4 pt. outriggers down																											
15.0	4 pt. outriggers down							7.0*	7.0*																5.6*	5.6*	8.36	
13.5	4 pt. outriggers down									6.5*	6.5*														5.2*	5.2*	10.08	
12.0	4 pt. outriggers down									6.3*	6.3*	6.1*	6.1*												4.9*	4.9*	11.34	
10.5	4 pt. outriggers down							6.9*	6.9*	6.4*	6.4*	6.1*	6.1*	5.5*	5.5*										4.8*	4.8*	12.29	
9.0	4 pt. outriggers down							7.3*	7.3*	6.7*	6.7*	6.2*	6.2*	5.8*	5.8*										4.8*	4.8*	12.99	
7.5	4 pt. outriggers down					9.3*	9.3*	8.0*	8.0*	7.1*	7.1*	6.4*	6.4*	6.0*	6.0*										4.9*	4.9*	13.48	
6.0	4 pt. outriggers down	21.3*	21.3*	13.9*	13.9*	10.6*	10.6*	8.8*	8.8*	7.6*	7.6*	6.7*	6.7*	6.1*	6.1*	5.6*	5.6*								5.0*	5.0*	13.80	
4.5	4 pt. outriggers down	2.1*	2.1*	16.1*	16.1*	12.0*	12.0*	9.6*	9.6*	8.1*	8.1*	7.1*	7.1*	6.3*	6.3*	5.7*	5.7*								5.2*	5.2*	13.94	
3.0	4 pt. outriggers down	1.8*	1.8*	7.2*	7.2*	13.1*	13.1*	10.3*	10.3*	8.5*	8.5*	7.3*	7.3*	6.5*	6.5*	5.8*	5.8*								5.4*	5.4*	13.92	
1.5	4 pt. outriggers down	3.1*	3.1*	6.4*	6.4*	13.7*	13.7*	10.7*	10.7*	8.8*	8.8*	7.5*	7.5*	6.5*	6.5*	5.7*	5.7*								5.6*	5.6*	13.73	
0	4 pt. outriggers down			6.9*	6.9*	12.4*	12.4*	10.8*	10.8*	8.9*	8.9*	7.5*	7.5*	6.5*	6.5*										5.6*	5.6*	13.37	
-1.5	4 pt. outriggers down					12.3*	12.3*	10.6*	10.6*	8.7*	8.7*	7.3*	7.3*	6.2*	6.2*										5.6*	5.6*	12.83	
-3.0	4 pt. outriggers down							9.9*	9.9*	8.2*	8.2*														6.9*	6.9*	10.47	
-4.5	4 pt. outriggers down																											

## Industrial Stick 7.50 m

m	Undercarriage	3.0 m		4.5 m		6.0 m		7.5 m		9.0 m		10.5 m		12.0 m		13.5 m		15.0 m		16.5 m		18.0 m		m				
21.0	4 pt. outriggers down																											
19.5	4 pt. outriggers down																											
18.0	4 pt. outriggers down																											
16.5	4 pt. outriggers down																									4.6*	4.6*	8.72
15.0	4 pt. outriggers down									5.7*	5.7*	4.3*	4.3*												4.2*	4.2*	10.60	
13.5	4 pt. outriggers down											5.3*	5.3*												3.9*	3.9*	11.99	
12.0	4 pt. outriggers down											5.2*	5.2*	5.1*	5.1*										3.7*	3.7*	13.07	
10.5	4 pt. outriggers down											5.3*	5.3*	5.1*	5.1*	4.4*	4.4*								3.7*	3.7*	13.89	
9.0	4 pt. outriggers down									5.8*	5.8*	5.5*	5.5*	5.2*	5.2*	5.0*	5.0*								3.7*	3.7*	14.52	
7.5	4 pt. outriggers down							6.8*	6.8*	6.2*	6.2*	5.7*	5.7*	5.3*	5.3*	5.0*	5.0*								3.7*	3.7*	14.96	
6.0	4 pt. outriggers down					8.8*	8.8*	7.6*	7.6*	6.7*	6.7*	6.1*	6.1*	5.6*	5.6*	5.2*	5.2*	4.3*	4.3*						3.8*	3.8*	15.24	
4.5	4 pt. outriggers down	21.0*	21.0*	13.7*	13.7*	10.4*	10.4*	8.5*	8.5*	7.3*	7.3*	6.4*	6.4*	5.8*	5.8*	5.3*	5.3*	4.8*	4.8*						3.9*	3.9*	15.37	
3.0	4 pt. outriggers down	4.4*	4.4*	16.3*	16.3*	11.8*	11.8*	9.4*	9.4*	7.8*	7.8*	6.8*	6.8*	6.0*	6.0*	5.4*	5.4*	4.9*	4.9*						4.0*	4.0*	15.35	
1.5	4 pt. outriggers down	3.7*	3.7*	8.5*	8.5*	12.8*	12.8*	10.0*	10.0*	8.3*	8.3*	7.1*	7.1*	6.2*	6.2*	5.5*	5.5*	4.9*	4.9*						4.3*	4.3*	15.19	
0	4 pt. outriggers down	4.2*	4.2*	7.3*	7.3*	13.4*	13.4*	10.5*	10.5*	8.6*	8.6*	7.3*	7.3*	6.3*	6.3*	5.5*	5.5*								4.6*	4.6*	14.86	
-1.5	4 pt. outriggers down	4.9*	4.9*	7.3*	7.3*	12.7*	12.7*	10.6*	10.6*	8.7*	8.7*	7.3*	7.3*	6.3*	6.3*	5.4*	5.4*								4.9*	4.9*	14.37	
-3.0	4 pt. outriggers down			7.8*	7.8*	12.3*	12.3*	10.3*	10.3*	8.5*	8.5*	7.1*	7.1*	6.0*	6.0*	5.0*	5.0*								5.0*	5.0*	13.56	
-4.5	4 pt. outriggers down							9.7*	9.7*	8.0*	8.0*	6.6*	6.6*												6.5*	6.5*	10.67	

Height Can be slewed through 360° In longitudinal position of undercarriage Max. reach \* Limited by hydr. capacity

The lift capacities on the stick end without attachment are stated in metric tons (t) and are valid on a firm, level supporting surface with blocked oscillating axle. These capacities can be slewed through 360° with the undercarriage in the transverse position. Capacities in the longitudinal position of the undercarriage (+/- 15°) are specified over the steering axle with the stabilisers raised and over the rigid axle with the stabilisers down. Indicated loads comply with the ISO 10567 standard and do not exceed 75 % of tipping or 87 % of hydraulic capacity.

In accordance with the harmonised EU Standard EN 474-5, hydraulic excavators used for lifting operations must be equipped with pipe rupture protection devices on the hoist cylinders and an overload warning device.

# Industrial Attachment

with Industrial-Type Straight Boom 8.60 m

## Attachment Envelope

Kinematic variants 2A/3B

- 1 with industrial stick 6.00 m
- 2 with industrial stick 7.50 m
- 3 with industrial stick 6.00 m and clamshell model 20 B
- 4 with industrial stick 7.50 m and clamshell model 20 B

## Operating Weight

Operating weight includes basic machine A 934 C HD Litronic High Rise with 4 point outriggers, hydraulic cab elevation, 4 solid tires and industrial application with industrial-type straight boom 8.60 m.

with clamshell model 20 B/1.50 m <sup>3</sup> shells for loose material	Weight
industrial stick 6.00 m	45,500 kg
industrial stick 7.50 m	45,700 kg

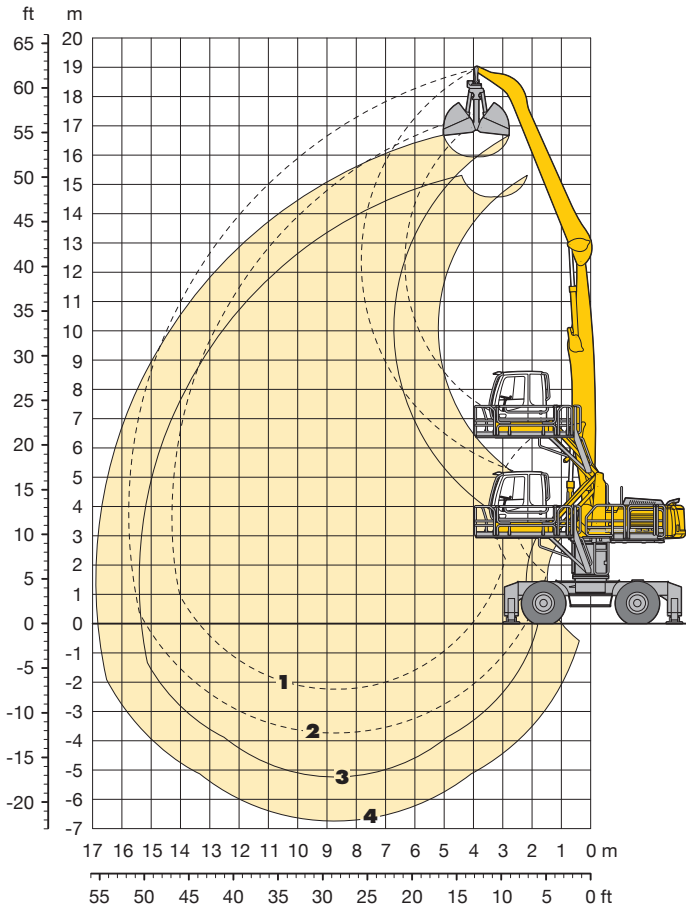

## VarioLiftPlus

**VarioLiftPlus:** Variable boom mounting positions for optimized lift capacities

with **the same** working range

with a **different** working range

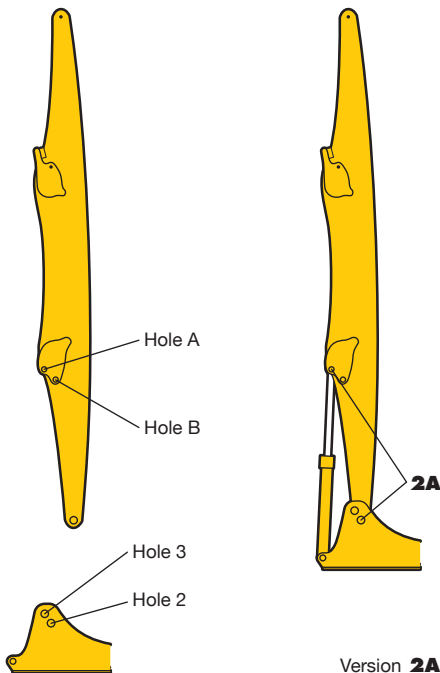

Version **2A**

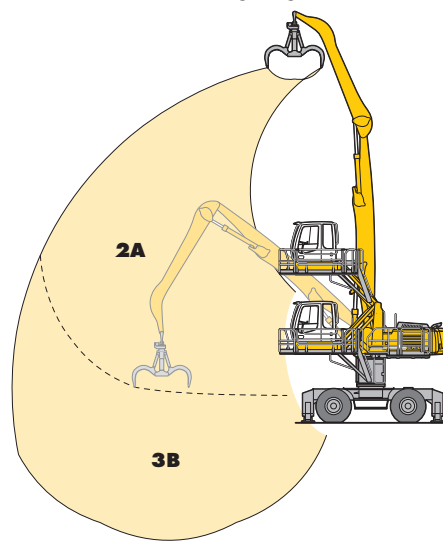

**Kinematic Variant 2A:**

Increased lift capacities above ground level

**Kinematic Variant 3B:**

Increased lift capacities below ground level and when working at large outreach

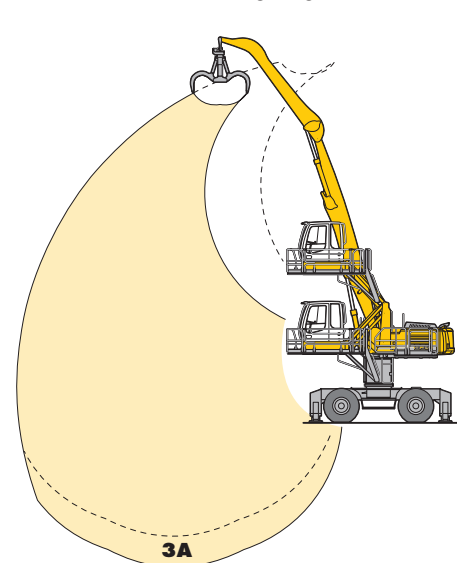

**Kinematic Variant 3A:**

Altered range curve with additional reach depth, e.g. for unloading from ships

# Lift Capacities

with Industrial-Type Straight Boom 8.60 m (Kinematic Variant 2A)

## Industrial Stick 6.00 m

m	Undercarriage	3.0 m		4.5 m		6.0 m		7.5 m		9.0 m		10.5 m		12.0 m		13.5 m		15.0 m		16.5 m		18.0 m		m			
21.0	4 pt. outriggers down																										
19.5	4 pt. outriggers down																										
18.0	4 pt. outriggers down																										
16.5	4 pt. outriggers down					8.1*	8.1*																	7.4*	7.4*	6.39	
15.0	4 pt. outriggers down					9.7*	9.7*	8.3*	8.3*															6.1*	6.1*	8.79	
13.5	4 pt. outriggers down							9.3*	9.3*	8.2*	8.2*													5.5*	5.5*	10.44	
12.0	4 pt. outriggers down							9.2*	9.2*	8.1*	8.1*	7.2*	7.2*											5.1*	5.1*	11.67	
10.5	4 pt. outriggers down							9.3*	9.3*	8.1*	8.1*	7.2*	7.2*	6.4*	6.4*									4.9*	4.9*	12.60	
9.0	4 pt. outriggers down					11.3*	11.3*	9.5*	9.5*	8.3*	8.3*	7.2*	7.2*	6.4*	6.4*									4.8*	4.8*	13.30	
7.5	4 pt. outriggers down			12.7*	12.7*	12.0*	12.0*	9.9*	9.9*	8.4*	8.4*	7.3*	7.3*	6.4*	6.4*	5.5*	5.5*							4.8*	4.8*	13.80	
6.0	4 pt. outriggers down	25.4*	25.4*	16.9*	16.9*	12.7*	12.7*	10.3*	10.3*	8.6*	8.6*	7.4*	7.4*	6.3*	6.3*	5.4*	5.4*							4.8*	4.8*	14.12	
4.5	4 pt. outriggers down			15.5*	15.5*	13.2*	13.2*	10.5*	10.5*	8.7*	8.7*	7.3*	7.3*	6.2*	6.2*	5.2*	5.2*							4.5*	4.5*	14.28	
3.0	4 pt. outriggers down			5.5*	5.5*	13.2*	13.2*	10.4*	10.4*	8.5*	8.5*	7.1*	7.1*	6.0*	6.0*	4.8*	4.8*							4.1*	4.1*	14.27	
1.5	4 pt. outriggers down			4.9*	4.9*	12.4*	12.4*	9.9*	9.9*	8.1*	8.1*	6.8*	6.8*	5.6*	5.6*	4.3*	4.3*							3.6*	3.6*	14.11	
0	4 pt. outriggers down			5.7*	5.7*	10.9*	10.9*	9.0*	9.0*	7.4*	7.4*	6.1*	6.1*	4.9*	4.9*									3.6*	3.6*	13.37	
-1.5	4 pt. outriggers down					8.7*	8.7*	7.5*	7.5*	6.3*	6.3*	5.1*	5.1*											4.2*	4.2*	11.56	
-3.0	4 pt. outriggers down																										
-4.5	4 pt. outriggers down																										

## Industrial Stick 7.50 m

m	Undercarriage	3.0 m		4.5 m		6.0 m		7.5 m		9.0 m		10.5 m		12.0 m		13.5 m		15.0 m		16.5 m		18.0 m		m			
21.0	4 pt. outriggers down																										
19.5	4 pt. outriggers down																										
18.0	4 pt. outriggers down					7.2*	7.2*																	6.2*	6.2*	6.68	
16.5	4 pt. outriggers down							7.2*	7.2*	5.5*	5.5*													5.0*	5.0*	9.25	
15.0	4 pt. outriggers down							7.8*	7.8*	7.0*	7.0*	5.4*	5.4*											4.4*	4.4*	11.04	
13.5	4 pt. outriggers down									7.5*	7.5*	6.7*	6.7*	4.9*	4.9*									4.1*	4.1*	12.39	
12.0	4 pt. outriggers down									7.5*	7.5*	6.7*	6.7*	6.1*	6.1*									3.9*	3.9*	13.44	
10.5	4 pt. outriggers down									7.5*	7.5*	6.8*	6.8*	6.1*	6.1*	5.3*	5.3*							3.7*	3.7*	14.26	
9.0	4 pt. outriggers down							8.7*	8.7*	7.7*	7.7*	6.8*	6.8*	6.1*	6.1*	5.5*	5.5*							3.7*	3.7*	14.88	
7.5	4 pt. outriggers down							9.1*	9.1*	7.9*	7.9*	6.9*	6.9*	6.2*	6.2*	5.5*	5.5*	4.6*	4.6*					3.7*	3.7*	15.33	
6.0	4 pt. outriggers down			8.9*	8.9*	11.2*	11.2*	9.6*	9.6*	8.2*	8.2*	7.1*	7.1*	6.2*	6.2*	5.4*	5.4*	4.6*	4.6*					3.7*	3.7*	15.62	
4.5	4 pt. outriggers down	25.2*	25.2*	16.6*	16.6*	12.5*	12.5*	10.0*	10.0*	8.4*	8.4*	7.2*	7.2*	6.2*	6.2*	5.3*	5.3*	4.5*	4.5*					3.7*	3.7*	15.76	
3.0	4 pt. outriggers down	2.4*	2.4*	16.7*	16.7*	13.0*	13.0*	10.3*	10.3*	8.5*	8.5*	7.1*	7.1*	6.1*	6.1*	5.2*	5.2*	4.2*	4.2*					3.6*	3.6*	15.75	
1.5	4 pt. outriggers down	2.2*	2.2*	6.9*	6.9*	12.9*	12.9*	10.2*	10.2*	8.3*	8.3*	7.0*	7.0*	5.9*	5.9*	4.9*	4.9*	3.8*	3.8*					3.2*	3.2*	15.61	
0	4 pt. outriggers down	3.0*	3.0*	6.1*	6.1*	12.1*	12.1*	9.7*	9.7*	7.9*	7.9*	6.6*	6.6*	5.5*	5.5*	4.4*	4.4*	3.2*	3.2*					2.9*	2.9*	15.19	
-1.5	4 pt. outriggers down			6.5*	6.5*	10.7*	10.7*	8.7*	8.7*	7.2*	7.2*	5.9*	5.9*	4.8*	4.8*	3.7*	3.7*							3.2*	3.2*	14.04	
-3.0	4 pt. outriggers down					8.6*	8.6*	7.3*	7.3*	6.0*	6.0*	4.9*	4.9*											3.9*	3.9*	11.91	
-4.5	4 pt. outriggers down																										

Height Can be slewed through 360° In longitudinal position of undercarriage Max. reach \* Limited by hydr. capacity

The lift capacities on the stick end without attachment are stated in metric tons (t) and are valid on a firm, level supporting surface with blocked oscillating axle. These capacities can be slewed through 360° with the undercarriage in the transverse position. Capacities in the longitudinal position of the undercarriage (+/- 15°) are specified over the steering axle with the stabilisers raised and over the rigid axle with the stabilisers down. Indicated loads comply with the ISO 10567 standard and do not exceed 75% of tipping or 87% of hydraulic capacity.

In accordance with the harmonised EU Standard EN 474-5, hydraulic excavators used for lifting operations must be equipped with pipe rupture protection devices on the hoist cylinders and an overload warning device.

# Lift Capacities

with Industrial-Type Straight Boom 8.60 m (Kinematic Variant 3B)

## Industrial Stick 6.00 m

↑ m	Undercarriage	3.0 m		4.5 m		6.0 m		7.5 m		9.0 m		10.5 m		12.0 m		13.5 m		15.0 m		16.5 m		18.0 m		m			
<b>21.0</b>	4 pt. outriggers down																										
<b>19.5</b>	4 pt. outriggers down																										
<b>18.0</b>	4 pt. outriggers down																										
<b>16.5</b>	4 pt. outriggers down					8.6*	8.6*																	7.2*	7.2*	6.81	
<b>15.0</b>	4 pt. outriggers down					8.6*	8.6*	7.8*	7.8*	6.3*	6.3*													6.0*	6.0*	9.10	
<b>13.5</b>	4 pt. outriggers down							7.5*	7.5*	7.0*	7.0*	6.0*	6.0*											5.4*	5.4*	10.70	
<b>12.0</b>	4 pt. outriggers down							7.4*	7.4*	6.8*	6.8*	6.4*	6.4*											5.1*	5.1*	11.89	
<b>10.5</b>	4 pt. outriggers down					8.4*	8.4*	7.6*	7.6*	6.9*	6.9*	6.4*	6.4*	6.1*	6.1*									4.9*	4.9*	12.80	
<b>9.0</b>	4 pt. outriggers down					9.1*	9.1*	8.0*	8.0*	7.2*	7.2*	6.6*	6.6*	6.1*	6.1*									4.8*	4.8*	13.47	
<b>7.5</b>	4 pt. outriggers down			12.4*	12.4*	10.1*	10.1*	8.6*	8.6*	7.5*	7.5*	6.8*	6.8*	6.2*	6.2*	5.7*	5.7*							4.8*	4.8*	13.95	
<b>6.0</b>	4 pt. outriggers down	22.9*	22.9*	14.9*	14.9*	11.3*	11.3*	9.3*	9.3*	8.0*	8.0*	7.0*	7.0*	6.3*	6.3*	5.8*	5.8*							4.8*	4.8*	14.26	
<b>4.5</b>	4 pt. outriggers down			10.7*	10.7*	12.6*	12.6*	10.0*	10.0*	8.4*	8.4*	7.3*	7.3*	6.5*	6.5*	5.8*	5.8*							4.9*	4.9*	14.39	
<b>3.0</b>	4 pt. outriggers down			4.8*	4.8*	13.5*	13.5*	10.6*	10.6*	8.8*	8.8*	7.5*	7.5*	6.6*	6.6*	5.8*	5.8*							5.1*	5.1*	14.37	
<b>1.5</b>	4 pt. outriggers down			4.7*	4.7*	12.3*	12.3*	10.9*	10.9*	9.0*	9.0*	7.6*	7.6*	6.6*	6.6*	5.6*	5.6*							5.1*	5.1*	14.19	
<b>0</b>	4 pt. outriggers down			5.6*	5.6*	11.1*	11.1*	10.8*	10.8*	8.9*	8.9*	7.5*	7.5*	6.4*	6.4*									5.4*	5.4*	13.35	
<b>-1.5</b>	4 pt. outriggers down							10.3*	10.3*	8.6*	8.6*	7.2*	7.2*											6.5*	6.5*	11.35	
<b>-3.0</b>	4 pt. outriggers down																										
<b>-4.5</b>	4 pt. outriggers down																										

## Industrial Stick 7.50 m

↑ m	Undercarriage	3.0 m		4.5 m		6.0 m		7.5 m		9.0 m		10.5 m		12.0 m		13.5 m		15.0 m		16.5 m		18.0 m		m			
<b>21.0</b>	4 pt. outriggers down																										
<b>19.5</b>	4 pt. outriggers down																										
<b>18.0</b>	4 pt. outriggers down					7.5*	7.5*																	6.0*	6.0*	7.12	
<b>16.5</b>	4 pt. outriggers down							7.1*	7.1*	5.9*	5.9*													4.9*	4.9*	9.58	
<b>15.0</b>	4 pt. outriggers down							6.6*	6.6*	6.2*	6.2*	5.7*	5.7*											4.4*	4.4*	11.31	
<b>13.5</b>	4 pt. outriggers down									6.0*	6.0*	5.7*	5.7*	5.3*	5.3*									4.1*	4.1*	12.63	
<b>12.0</b>	4 pt. outriggers down									5.9*	5.9*	5.6*	5.6*	5.4*	5.4*	4.2*	4.2*							3.9*	3.9*	13.65	
<b>10.5</b>	4 pt. outriggers down							6.4*	6.4*	6.0*	6.0*	5.7*	5.7*	5.4*	5.4*	5.2*	5.2*							3.7*	3.7*	14.44	
<b>9.0</b>	4 pt. outriggers down							6.8*	6.8*	6.3*	6.3*	5.9*	5.9*	5.5*	5.5*	5.2*	5.2*	3.8*	3.8*					3.7*	3.7*	15.04	
<b>7.5</b>	4 pt. outriggers down					8.3*	8.3*	7.4*	7.4*	6.7*	6.7*	6.1*	6.1*	5.6*	5.6*	5.3*	5.3*	4.9*	4.9*					3.7*	3.7*	15.47	
<b>6.0</b>	4 pt. outriggers down			9.1*	9.1*	9.6*	9.6*	8.2*	8.2*	7.2*	7.2*	6.4*	6.4*	5.8*	5.8*	5.4*	5.4*	5.0*	5.0*					3.7*	3.7*	15.75	
<b>4.5</b>	4 pt. outriggers down	22.6*	22.6*	14.6*	14.6*	11.1*	11.1*	9.0*	9.0*	7.7*	7.7*	6.8*	6.8*	6.0*	6.0*	5.5*	5.5*	5.0*	5.0*					3.7*	3.7*	15.87	
<b>3.0</b>	4 pt. outriggers down	1.9*	1.9*	12.0*	12.0*	12.4*	12.4*	9.8*	9.8*	8.2*	8.2*	7.1*	7.1*	6.2*	6.2*	5.6*	5.6*	5.0*	5.0*					3.8*	3.8*	15.85	
<b>1.5</b>	4 pt. outriggers down	2.1*	2.1*	6.2*	6.2*	13.2*	13.2*	10.4*	10.4*	8.5*	8.5*	7.3*	7.3*	6.4*	6.4*	5.6*	5.6*	4.9*	4.9*					4.0*	4.0*	15.69	
<b>0</b>	4 pt. outriggers down	3.0*	3.0*	5.8*	5.8*	13.1*	13.1*	10.6*	10.6*	8.7*	8.7*	7.4*	7.4*	6.4*	6.4*	5.5*	5.5*	4.7*	4.7*					4.5*	4.5*	15.20	
<b>-1.5</b>	4 pt. outriggers down			6.3*	6.3*	11.7*	11.7*	10.6*	10.6*	8.7*	8.7*	7.3*	7.3*	6.2*	6.2*	5.3*	5.3*							5.0*	5.0*	13.98	
<b>-3.0</b>	4 pt. outriggers down					11.9*	11.9*	10.1*	10.1*	8.3*	8.3*	7.0*	7.0*											6.1*	6.1*	11.66	
<b>-4.5</b>	4 pt. outriggers down																										

↑ Height Can be slewed through 360° In longitudinal position of undercarriage Max. reach \* Limited by hydr. capacity

The lift capacities on the stick end without attachment are stated in metric tons (t) and are valid on a firm, level supporting surface with blocked oscillating axle. These capacities can be slewed through 360° with the undercarriage in the transverse position. Capacities in the longitudinal position of the undercarriage (+/- 15°) are specified over the steering axle with the stabilisers raised and over the rigid axle with the stabilisers down. Indicated loads comply with the ISO 10567 standard and do not exceed 75 % of tipping or 87 % of hydraulic capacity. In accordance with the harmonised EU Standard EN 474-5, hydraulic excavators used for lifting operations must be equipped with pipe rupture protection devices on the hoist cylinders and an overload warning device.



# Industrial Attachment

with Industrial-Type Straight Boom 9.60 m

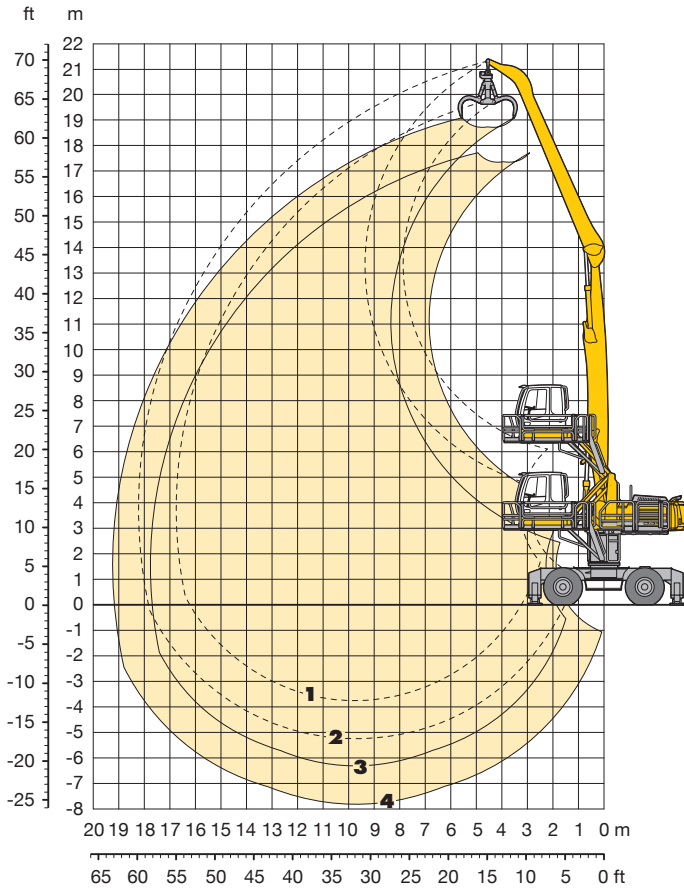

## Attachment Envelope

Kinematic variants 2A/3B

- 1 with industrial stick 7.50 m
- 2 with industrial stick 9.00 m
- 3 with industrial stick 7.50 m and grapple model 65
- 4 with industrial stick 9.00 m and grapple model 65

## Operating Weight

Operating weight includes basic machine A 934 C HD Litronic High Rise with 4 point outriggers, hydraulic cab elevation, 4 solid tires and industrial application with industrial-type straight boom 9.60 m.

with grapple model 65/0.60 m <sup>3</sup> semi-closed tines	Weight
industrial stick 7.50 m	46,100 kg
industrial stick 9.00 m	46,400 kg

## VarioliftPlus

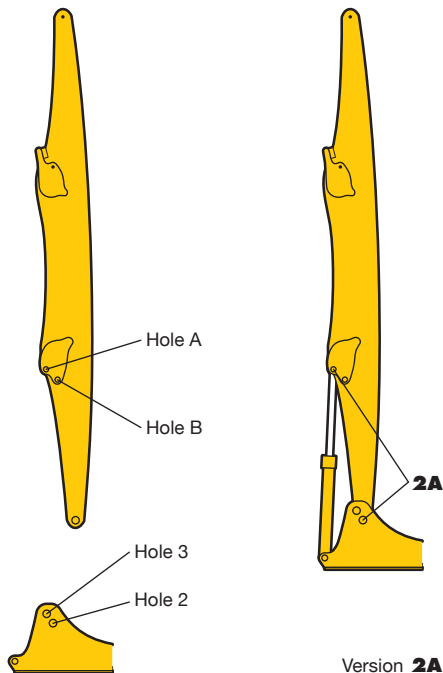

Version 2A

**VarioliftPlus:** Variable boom mounting positions for optimized lift capacities

with **the same** working range

with a **different** working range

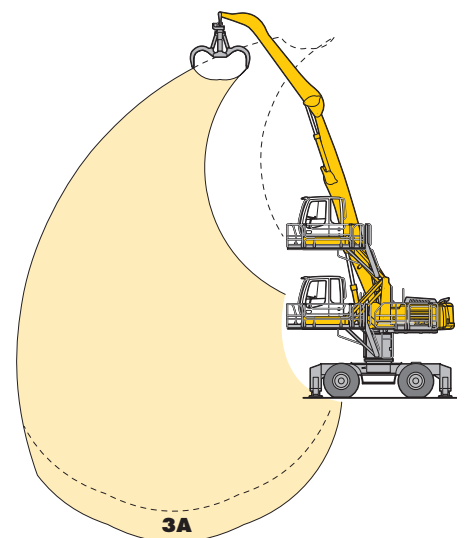
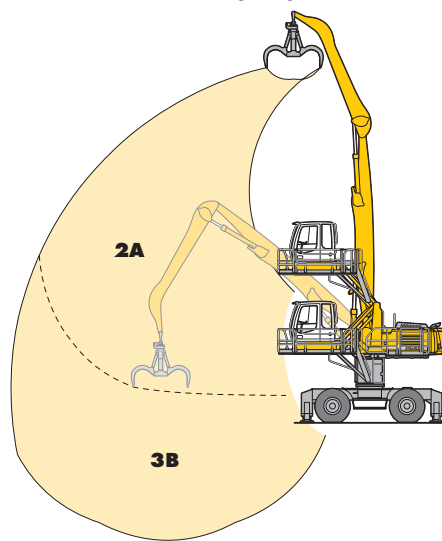

### Kinematic Variant 2A:

Increased lift capacities above ground level

### Kinematic Variant 3B:

Increased lift capacities below ground level and when working at large outreach

### Kinematic Variant 3A:

Altered range curve with additional reach depth, e.g. for unloading from ships

# Lift Capacities

with Industrial-Type Straight Boom 9.60 m (Kinematic Variant 2A)

## Industrial Stick 7.50 m

↑ m	Undercarriage	3.0 m		4.5 m		6.0 m		7.5 m		9.0 m		10.5 m		12.0 m		13.5 m		15.0 m		16.5 m		18.0 m		m					
<b>21.0</b>	4 pt. outriggers down																												
<b>19.5</b>	4 pt. outriggers down																								7.0*	7.0*	5.57		
<b>18.0</b>	4 pt. outriggers down							6.9*	6.9*																5.3*	5.3*	8.76		
<b>16.5</b>	4 pt. outriggers down							7.7*	7.7*	6.8*	6.8*	5.2*	5.2*												4.6*	4.6*	10.84		
<b>15.0</b>	4 pt. outriggers down									7.4*	7.4*	6.6*	6.6*	5.0*	5.0*											4.2*	4.2*	12.40	
<b>13.5</b>	4 pt. outriggers down									7.3*	7.3*	6.5*	6.5*	5.9*	5.9*	4.2*	4.2*									4.0*	4.0*	13.62	
<b>12.0</b>	4 pt. outriggers down									7.3*	7.3*	6.5*	6.5*	5.8*	5.8*	5.2*	5.2*									3.8*	3.8*	14.58	
<b>10.5</b>	4 pt. outriggers down							8.6*	8.6*	7.4*	7.4*	6.6*	6.6*	5.9*	5.9*	5.2*	5.2*	4.5*	4.5*							3.7*	3.7*	15.33	
<b>9.0</b>	4 pt. outriggers down							8.8*	8.8*	7.6*	7.6*	6.7*	6.7*	5.9*	5.9*	5.2*	5.2*	4.6*	4.6*							3.7*	3.7*	15.91	
<b>7.5</b>	4 pt. outriggers down					10.0*	10.0*	9.2*	9.2*	7.8*	7.8*	6.8*	6.8*	5.9*	5.9*	5.2*	5.2*	4.6*	4.6*							3.7*	3.7*	16.33	
<b>6.0</b>	4 pt. outriggers down	9.7*	9.7*	13.5*	13.5*	11.9*	11.9*	9.6*	9.6*	8.0*	8.0*	6.8*	6.8*	5.9*	5.9*	5.2*	5.2*	4.5*	4.5*	3.7*	3.7*					3.6*	3.6*	16.60	
<b>4.5</b>	4 pt. outriggers down			16.8*	16.8*	12.4*	12.4*	9.8*	9.8*	8.1*	8.1*	6.9*	6.9*	5.9*	5.9*	5.1*	5.1*	4.4*	4.4*	3.5*	3.5*					3.3*	3.3*	16.74	
<b>3.0</b>	4 pt. outriggers down			4.5*	4.5*	12.5*	12.5*	9.8*	9.8*	8.1*	8.1*	6.8*	6.8*	5.8*	5.8*	4.9*	4.9*	4.2*	4.2*	3.2*	3.2*					3.0*	3.0*	16.73	
<b>1.5</b>	4 pt. outriggers down	1.0*	1.0*	3.5*	3.5*	9.8*	9.8*	9.5*	9.5*	7.8*	7.8*	6.6*	6.6*	5.5*	5.5*	4.7*	4.7*	3.8*	3.8*	2.8*	2.8*					2.7*	2.7*	16.59	
<b>0</b>	4 pt. outriggers down			3.9*	3.9*	8.0*	8.0*	8.8*	8.8*	7.3*	7.3*	6.1*	6.1*	5.1*	5.1*	4.3*	4.3*	3.4*	3.4*							2.4*	2.4*	16.19	
<b>-1.5</b>	4 pt. outriggers down			4.7*	4.7*	8.0*	8.0*	7.8*	7.8*	6.5*	6.5*	5.5*	5.5*	4.6*	4.6*	3.7*	3.7*	2.7*	2.7*							2.6*	2.6*	15.04	
<b>-3.0</b>	4 pt. outriggers down							6.3*	6.3*	5.4*	5.4*	4.6*	4.6*	3.7*	3.7*											3.2*	3.2*	12.91	
<b>-4.5</b>	4 pt. outriggers down																												

## Industrial Stick 9.00 m

↑ m	Undercarriage	3.0 m		4.5 m		6.0 m		7.5 m		9.0 m		10.5 m		12.0 m		13.5 m		15.0 m		16.5 m		18.0 m		m				
<b>21.0</b>	4 pt. outriggers down																									6.2*	6.2*	5.71
<b>19.5</b>	4 pt. outriggers down							6.1*	6.1*	4.7*	4.7*															4.6*	4.6*	9.10
<b>18.0</b>	4 pt. outriggers down									5.9*	5.9*	4.9*	4.9*													3.9*	3.9*	11.32
<b>16.5</b>	4 pt. outriggers down									6.4*	6.4*	5.7*	5.7*	4.7*	4.7*											3.5*	3.5*	13.00
<b>15.0</b>	4 pt. outriggers down											6.1*	6.1*	5.5*	5.5*	4.4*	4.4*									3.3*	3.3*	14.32
<b>13.5</b>	4 pt. outriggers down											6.1*	6.1*	5.5*	5.5*	5.0*	5.0*	3.8*	3.8*							3.1*	3.1*	15.39
<b>12.0</b>	4 pt. outriggers down											6.1*	6.1*	5.5*	5.5*	5.0*	5.0*	4.5*	4.5*							3.0*	3.0*	16.25
<b>10.5</b>	4 pt. outriggers down							6.9*	6.9*	6.1*	6.1*	6.1*	6.1*	5.5*	5.5*	5.0*	5.0*	4.5*	4.5*	3.7*	3.7*					2.9*	2.9*	16.93
<b>9.0</b>	4 pt. outriggers down							7.1*	7.1*	7.1*	7.1*	6.3*	6.3*	5.6*	5.6*	5.0*	5.0*	4.5*	4.5*	4.0*	4.0*					2.9*	2.9*	17.45
<b>7.5</b>	4 pt. outriggers down							7.4*	7.4*	7.3*	7.3*	6.4*	6.4*	5.7*	5.7*	5.0*	5.0*	4.5*	4.5*	3.9*	3.9*					2.9*	2.9*	17.83
<b>6.0</b>	4 pt. outriggers down					7.5*	7.5*	8.9*	8.9*	7.6*	7.6*	6.5*	6.5*	5.7*	5.7*	5.0*	5.0*	4.4*	4.4*	3.9*	3.9*	3.1*	3.1*			2.9*	2.9*	18.08
<b>4.5</b>	4 pt. outriggers down	3.1*	3.1*	10.6*	10.6*	11.6*	11.6*	9.3*	9.3*	7.8*	7.8*	6.6*	6.6*	5.8*	5.8*	5.0*	5.0*	4.4*	4.4*	3.8*	3.8*	3.0*	3.0*			2.9*	2.9*	18.20
<b>3.0</b>	4 pt. outriggers down	4.7*	4.7*	16.6*	16.6*	12.2*	12.2*	9.6*	9.6*	7.9*	7.9*	6.7*	6.7*	5.7*	5.7*	5.0*	5.0*	4.3*	4.3*	3.6*	3.6*	2.8*	2.8*			2.6*	2.6*	18.20
<b>1.5</b>	4 pt. outriggers down	1.5*	1.5*	5.5*	5.5*	12.2*	12.2*	9.6*	9.6*	7.9*	7.9*	6.6*	6.6*	5.6*	5.6*	4.8*	4.8*	4.1*	4.1*	3.4*	3.4*	2.4*	2.4*			2.4*	2.4*	18.07
<b>0</b>	4 pt. outriggers down	2.0*	2.0*	4.4*	4.4*	10.5*	10.5*	9.3*	9.3*	7.6*	7.6*	6.3*	6.3*	5.4*	5.4*	4.5*	4.5*	3.8*	3.8*	3.0*	3.0*					2.0*	2.0*	17.82
<b>-1.5</b>	4 pt. outriggers down	2.7*	2.7*	4.6*	4.6*	8.6*	8.6*	8.6*	8.6*	7.1*	7.1*	5.9*	5.9*	5.0*	5.0*	4.1*	4.1*	3.4*	3.4*	2.5*	2.5*					2.1*	2.1*	17.00
<b>-3.0</b>	4 pt. outriggers down			5.1*	5.1*	8.4*	8.4*	7.5*	7.5*	6.3*	6.3*	5.3*	5.3*	4.4*	4.4*	3.6*	3.6*	2.7*	2.7*							2.3*	2.3*	15.63
<b>-4.5</b>	4 pt. outriggers down							6.1*	6.1*	5.2*	5.2*	4.3*	4.3*	3.5*	3.5*											2.9*	2.9*	13.23

Height Can be slewed through 360° In longitudinal position of undercarriage Max. reach \* Limited by hydr. capacity

The lift capacities on the stick end without attachment are stated in metric tons (t) and are valid on a firm, level supporting surface with blocked oscillating axle. These capacities can be slewed through 360° with the undercarriage in the transverse position. Capacities in the longitudinal position of the undercarriage (+/- 15°) are specified over the steering axle with the stabilisers raised and over the rigid axle with the stabilisers down. Indicated loads comply with the ISO 10567 standard and do not exceed 75 % of tipping or 87 % of hydraulic capacity.

In accordance with the harmonised EU Standard EN 474-5, hydraulic excavators used for lifting operations must be equipped with pipe rupture protection devices on the hoist cylinders and an overload warning device.

# Lift Capacities

with Industrial-Type Straight Boom 9.60 m (Kinematic Variant 3B)

## Industrial Stick 7.50 m

m	Undercarriage	3.0 m		4.5 m		6.0 m		7.5 m		9.0 m		10.5 m		12.0 m		13.5 m		15.0 m		16.5 m		18.0 m		m			
21.0	4 pt. outriggers down																										
19.5	4 pt. outriggers down					6.9*	6.9*																	6.7*	6.7*	6.12	
18.0	4 pt. outriggers down							7.1*	7.1*	5.4*	5.4*													5.2*	5.2*	9.12	
16.5	4 pt. outriggers down							6.7*	6.7*	6.1*	6.1*	5.6*	5.6*											4.6*	4.6*	11.14	
15.0	4 pt. outriggers down									5.9*	5.9*	5.5*	5.5*	5.2*	5.2*										4.2*	4.2*	12.66
13.5	4 pt. outriggers down									5.8*	5.8*	5.4*	5.4*	5.1*	5.1*	4.7*	4.7*								3.9*	3.9*	13.84
12.0	4 pt. outriggers down									5.8*	5.8*	5.4*	5.4*	5.1*	5.1*	4.8*	4.8*								3.8*	3.8*	14.78
10.5	4 pt. outriggers down							6.6*	6.6*	6.0*	6.0*	5.5*	5.5*	5.1*	5.1*	4.8*	4.8*	4.5*	4.5*						3.7*	3.7*	15.51
9.0	4 pt. outriggers down							7.0*	7.0*	6.3*	6.3*	5.7*	5.7*	5.2*	5.2*	4.9*	4.9*	4.5*	4.5*						3.7*	3.7*	16.07
7.5	4 pt. outriggers down					9.0*	9.0*	7.6*	7.6*	6.7*	6.7*	5.9*	5.9*	5.4*	5.4*	5.0*	5.0*	4.6*	4.6*						3.7*	3.7*	16.48
6.0	4 pt. outriggers down	12.2*	12.2*	13.3*	13.3*	10.1*	10.1*	8.3*	8.3*	7.1*	7.1*	6.2*	6.2*	5.6*	5.6*	5.1*	5.1*	4.6*	4.6*	4.2*	4.2*				3.7*	3.7*	16.73
4.5	4 pt. outriggers down			13.2*	13.2*	11.4*	11.4*	9.0*	9.0*	7.5*	7.5*	6.5*	6.5*	5.8*	5.8*	5.2*	5.2*	4.7*	4.7*	4.2*	4.2*				3.7*	3.7*	16.85
3.0	4 pt. outriggers down			3.8*	3.8*	12.3*	12.3*	9.6*	9.6*	7.9*	7.9*	6.8*	6.8*	5.9*	5.9*	5.3*	5.3*	4.7*	4.7*	4.2*	4.2*				3.9*	3.9*	16.83
1.5	4 pt. outriggers down	1.0*	1.0*	3.3*	3.3*	8.7*	8.7*	10.0*	10.0*	8.2*	8.2*	6.9*	6.9*	6.0*	6.0*	5.3*	5.3*	4.7*	4.7*	4.0*	4.0*				3.9*	3.9*	16.68
0	4 pt. outriggers down			3.8*	3.8*	7.5*	7.5*	10.1*	10.1*	8.3*	8.3*	7.0*	7.0*	6.0*	6.0*	5.2*	5.2*	4.5*	4.5*						3.9*	3.9*	16.20
-1.5	4 pt. outriggers down					7.7*	7.7*	9.9*	9.9*	8.1*	8.1*	6.9*	6.9*	5.9*	5.9*	5.1*	5.1*								4.3*	4.3*	14.98
-3.0	4 pt. outriggers down							9.3*	9.3*	7.8*	7.8*	6.6*	6.6*	5.6*	5.6*										5.2*	5.2*	12.64
-4.5	4 pt. outriggers down																										

## Industrial Stick 9.00 m

m	Undercarriage	3.0 m		4.5 m		6.0 m		7.5 m		9.0 m		10.5 m		12.0 m		13.5 m		15.0 m		16.5 m		18.0 m		m		
21.0	4 pt. outriggers down					6.3*	6.3*																	5.9*	5.9*	6.29
19.5	4 pt. outriggers down							6.3*	6.3*	5.1*	5.1*													4.5*	4.5*	9.48
18.0	4 pt. outriggers down									5.6*	5.6*	5.1*	5.1*											3.9*	3.9*	11.63
16.5	4 pt. outriggers down									5.3*	5.3*	5.0*	5.0*	4.7*	4.7*									3.5*	3.5*	13.27
15.0	4 pt. outriggers down											4.8*	4.8*	4.6*	4.6*	4.4*	4.4*							3.3*	3.3*	14.56
13.5	4 pt. outriggers down											4.7*	4.7*	4.5*	4.5*	4.3*	4.3*	4.0*	4.0*					3.1*	3.1*	15.60
12.0	4 pt. outriggers down											4.8*	4.8*	4.5*	4.5*	4.3*	4.3*	4.1*	4.1*					3.0*	3.0*	16.44
10.5	4 pt. outriggers down									5.2*	5.2*	4.9*	4.9*	4.6*	4.6*	4.3*	4.3*	4.1*	4.1*	3.9*	3.9*			2.9*	2.9*	17.10
9.0	4 pt. outriggers down									5.5*	5.5*	5.1*	5.1*	4.7*	4.7*	4.4*	4.4*	4.1*	4.1*	3.9*	3.9*			2.9*	2.9*	17.61
7.5	4 pt. outriggers down							6.6*	6.6*	5.9*	5.9*	5.3*	5.3*	4.9*	4.9*	4.5*	4.5*	4.2*	4.2*	3.9*	3.9*			2.9*	2.9*	17.98
6.0	4 pt. outriggers down					7.6*	7.6*	7.3*	7.3*	6.3*	6.3*	5.6*	5.6*	5.1*	5.1*	4.7*	4.7*	4.3*	4.3*	4.0*	4.0*	3.4*	3.4*	2.9*	2.9*	18.21
4.5	4 pt. outriggers down			12.1*	12.1*	9.9*	9.9*	8.0*	8.0*	6.8*	6.8*	6.0*	6.0*	5.3*	5.3*	4.8*	4.8*	4.4*	4.4*	4.0*	4.0*	3.6*	3.6*	2.9*	2.9*	18.32
3.0	4 pt. outriggers down	3.5*	3.5*	14.0*	14.0*	11.1*	11.1*	8.8*	8.8*	7.3*	7.3*	6.3*	6.3*	5.5*	5.5*	4.9*	4.9*	4.5*	4.5*	4.0*	4.0*	3.6*	3.6*	3.0*	3.0*	18.30
1.5	4 pt. outriggers down	1.4*	1.4*	4.8*	4.8*	12.0*	12.0*	9.4*	9.4*	7.7*	7.7*	6.5*	6.5*	5.7*	5.7*	5.0*	5.0*	4.5*	4.5*	4.0*	4.0*	3.5*	3.5*	3.1*	3.1*	18.16
0	4 pt. outriggers down	2.0*	2.0*	4.2*	4.2*	9.5*	9.5*	9.7*	9.7*	7.9*	7.9*	6.7*	6.7*	5.8*	5.8*	5.1*	5.1*	4.5*	4.5*	4.0*	4.0*			3.3*	3.3*	17.89
-1.5	4 pt. outriggers down	2.7*	2.7*	4.4*	4.4*	8.1*	8.1*	9.8*	9.8*	8.0*	8.0*	6.8*	6.8*	5.8*	5.8*	5.0*	5.0*	4.4*	4.4*	3.8*	3.8*			3.5*	3.5*	16.99
-3.0	4 pt. outriggers down			5.0*	5.0*	8.0*	8.0*	9.6*	9.6*	7.9*	7.9*	6.6*	6.6*	5.7*	5.7*	4.9*	4.9*	4.2*	4.2*					3.9*	3.9*	15.54
-4.5	4 pt. outriggers down							9.1*	9.1*	7.5*	7.5*	6.3*	6.3*	5.4*	5.4*									4.9*	4.9*	12.92

Height Can be slewed through 360° In longitudinal position of undercarriage Max. reach \* Limited by hydr. capacity

The lift capacities on the stick end without attachment are stated in metric tons (t) and are valid on a firm, level supporting surface with blocked oscillating axle. These capacities can be slewed through 360° with the undercarriage in the transverse position. Capacities in the longitudinal position of the undercarriage (+/- 15°) are specified over the steering axle with the stabilisers raised and over the rigid axle with the stabilisers down. Indicated loads comply with the ISO 10567 standard and do not exceed 75 % of tipping or 87 % of hydraulic capacity.

In accordance with the harmonised EU Standard EN 474-5, hydraulic excavators used for lifting operations must be equipped with pipe rupture protection devices on the hoist cylinders and an overload warning device.

# Choice of Cab Elevation and Cab Protection

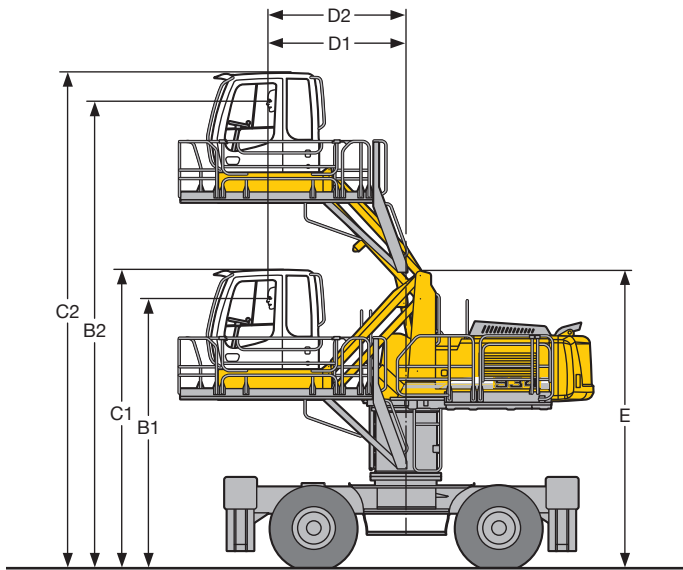

## Hydraulic Cab Elevation (Parallelogram) + Intermediate Piece 0.35 m

B1	4,690 mm
B2	8,110 mm
C1	5,185 mm
C2	8,610 mm
D1	2,400 mm
D2	2,395 mm
E	5,175 mm

The parallelogram cab raiser allows the operator to choose his field of view between dimensions B1 and B2. For a transport height lower than C1 the shell of the cab can be removed. The overall height is then E.

As cab protection a front window screen can be installed.

### Grille above

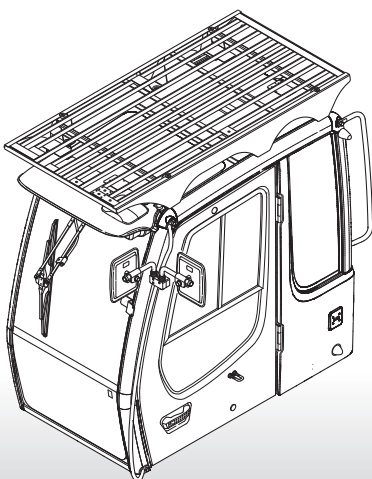

### Grilles in front

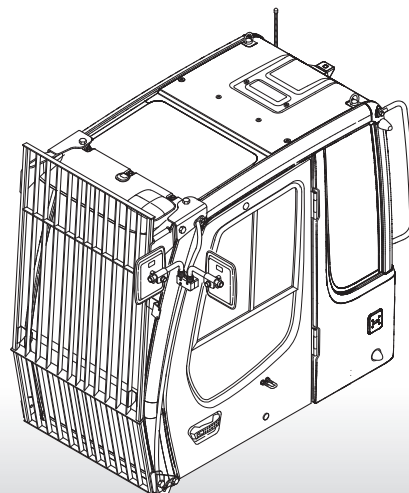



# Variety of Tools

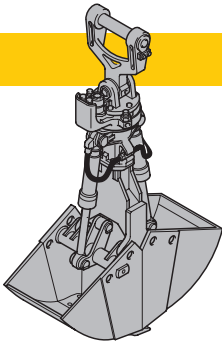

## Shells for Loose Material

### Clamshell Model 20 B

Shells for loose material with cutting edge (without teeth)

Cutting width of shells	mm	1,000	1,200	1,600
Capacity	m <sup>3</sup>	1.30	1.50	2.00
For loose material, specific weight up to	t/m <sup>3</sup>	1.5	1.5	1.5
Weight	kg	1,355	1,415	1,550

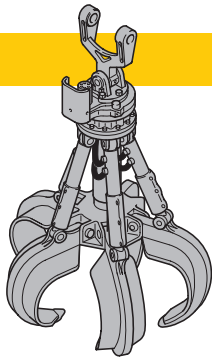

## Multiple Tine Grapples

open tines

semi-closed tines

closed tines

<b>Grapple Model 64</b> (4 tines)	Capacity	m <sup>3</sup>	0.40	0.60	0.40	0.60	0.40	0.60
	Weight	kg	845	1,130	1,055	1,330	1,060	1,520
<b>Grapple Model 65</b> (5 tines)	Capacity	m <sup>3</sup>	0.40	0.60	0.40	0.60	0.40	0.60
	Weight	kg	1,150	1,230	1,285	1,415	1,325	1,520
<b>Grapple Model 69</b> (4 tines)	Capacity	m <sup>3</sup>	0.80	1.10	0.80	1.10	0.80	1.10
	Weight	kg	1,345	1,395	1,535	1,640	1,900	2,060
<b>Grapple Model 70 C</b> (5 tines)	Capacity	m <sup>3</sup>	0.80	1.10	0.80	1.10	0.80	1.10
	Weight	kg	1,485	1,590	1,705	1,860	1,950	1,995

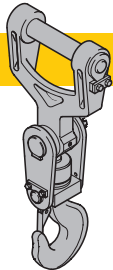

## Crane Hook with Suspension

Max. load	t	12.5
Height with suspension	mm	930
Weight	kg	96

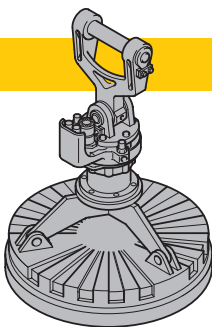

## Magnet Devices/Lifting Magnets

Generator	kW	13	20
<b>Electromagnets with Suspension</b>			
Power	kW	8.5	10
Dia of magnet	mm	1,300	1,400
Height with suspension	mm	1,100	1,100
Weight	kg	1,350	1,830

# Equipment



## Undercarriage

Two circuit travel brake with accumulator	•
Travel motor protection	+
Outtrigger cylinder rod guards	+
Creeper speed electrically switchable from cab	•
New tires	•
Service free parking brake	•
Independent outtrigger control	•
Choice of tires	+
Auto check valve directly on each stabilizer cylinder	•
Proportional power steering	•
Customized colors	+
Two lockable storage boxes	•
Two-speed power shift transmission	•



## Uppercarriage

Electric fuel tank filler pump	+
Maintenance-free swing brake lock	•
Handrails, Non slip surfaces	•
Main switch for electric circuit	•
Maintenance-free HD-batteries	•
Engine hood with lift help	•
Pedal controlled positioning swing brake	•
Reverse travel warning system	+
Rear area monitoring (country-dependent Standard or Option)	•/+
Sound insulation	•
Customized colors	+
Lockable tool box	•
Tool kit	•



## Hydraulics

Hydraulic tank shut-off valve	•
Extra hydr. control for hydr. swivel	+
Pressure compensation	•
Hook up for pressure checks	•
Pressure storage for controlled lowering of attachments with engine turned off	•
Filter with partial micro filtration (5 µm)	•
Electronic pump regulation	•
Stepless mode system (ECO)	•
Flow compensation	•
Four mixed modes, can also be adjusted	•
Full flow micro filtration	+
Bio degradable hydraulic oil	+
Tool Control	+
Additional hydraulic circuits	+



## Engine

Turbo charger	•
After-cooled	•
Sensor controlled engine idling	•
Liebherr particle filter	+
Unit pump system	•
Air filter with pre-cleaner main- and safety element	•



## Operator's Cab

Storage tray	•
Displays for engine operating condition	•
Mechanical hour meters, readable from outside the cab	•
Roof hatch	•
6-way adjustable seat	•
Airpressure operator seat with heating and head-rest	+
Seat and consoles independently adjustable	•
Extinguisher	+
Removable customized foot mat	•
Dome light	•
Hydraulic cab elevation	+
Rigid cab elevation	+
Cab heater with defroster	•
Cloth hook	•
Air conditioning	•
Electric cool box	+
Steering wheel adjustable	•
Bullet proof window (fixed installation – can not be opened)	+
Stereo radio	+
Preparation for radio installation	+
Rain hood over front window opening	•
Beacon	+
All tinted windows	•
Door with sliding window	•
Optical warning if outriggers are not fully retracted	+
Auxiliary heating	+
Sun shade	+
Sun roller blind	•
Electronic drive away lock	+
Wiper/washer	•
Cigarette lighter and ashtray	•
Additional flood lights	+



## Attachment

Flood lights	•
Hydr. lines for clam operation in sticks	•
Industrial-type gooseneck sticks with remote hydraulic pin puller	+
Sealed pivots	•
Safety lift hook	+
Liebherr line of clams	+
Liebherr semi-automatic central lubrication system	•
Liebherr fully-automatic central lubrication system	+
Likufix	+
Safety check valves on hoist cylinder	•
Safety check valves on stick cylinder	•
Hose quick connection	•
Hydraulic or manual quick change tool adapter	+
Customized colors	+
Special buckets and other tools	+
Overload warning device	+
Two way valves for bucket/clam use	+
Locking of connections for clam operation	+
Cylinders with shock absorber	•

• = Standard, + = Option

**Options and/or special attachments, supplied by vendors other than Liebherr, are only to be installed with the knowledge and approval of Liebherr to retain warranty.**