

(200 bar)	12 volt	24 volt
Pump - Motor Unit	245 A	145 A
Magnet (hydraulic unit)	4,2 A	2,1 A
Magnet (electric safety valve)	1,5 A	0,75 A
Solenoid	1,8 A	0,9 A
Cable area:		
Control cable	1,5 mm ²	1,5 mm ²
Main cable 0-8 m	35 mm ²	35 mm ²
Main cable 8-15 m	50 mm ²	35 mm ²
Main cable >15 m	-	50 mm ²
Power source:		
Min. capacity	180 Ah	170 Ah
Min. voltage	9 Volt	18 Volt

Loading diagram

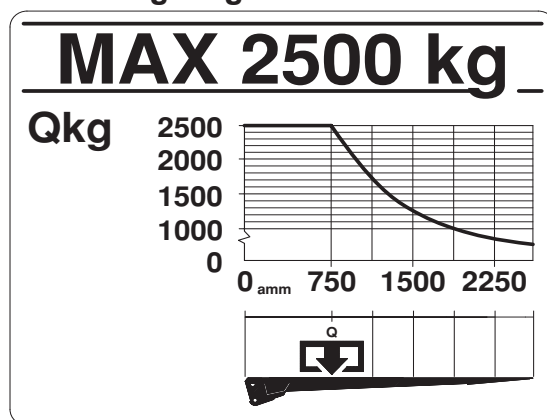

Dimensions for installation (mm)

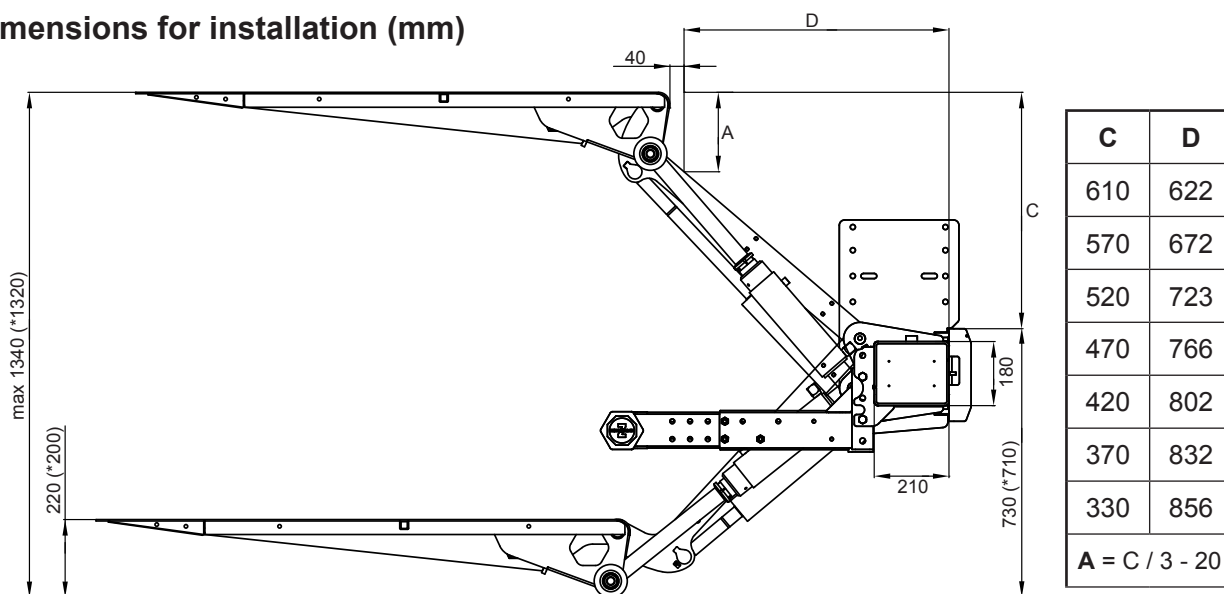

* without support wheels

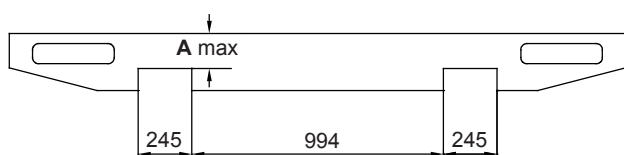
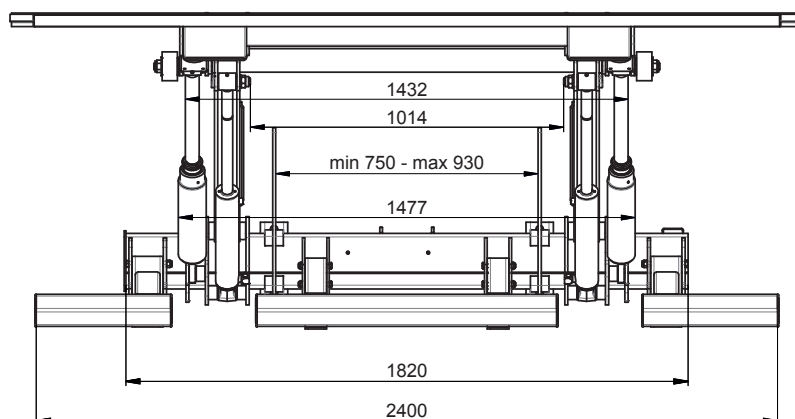
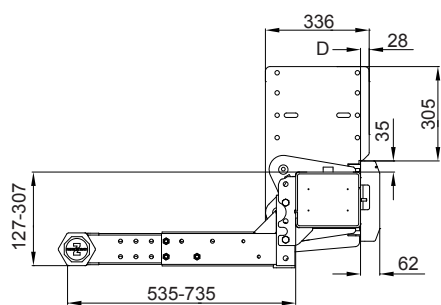

ZEPRO

ZEPRO Sales
 Tel: +46 (0)150 489 550
 Fax: +46 (0)150 489 551, +46 (0)150 489 566
 E-mail: zezero@zezero.com. Internet: www.zezero.com