

We build a better future

HL780-9

Equipped with Tier 3 Engine



*Photo may include optional equipment.

Pleasure works

An operator, who takes pleasure in his work, does a better job. That is why we at Hyundai Heavy Industries do everything we can to make that happen. We merged operator preference, fast precision and lasting performance into a quality product. Hyundai 9 Series earthmoving equipment simply makes time fly, makes pleasure work!



*Photo may include optional equipment.

Reliable Main Components

Engine Technology

Proven, reliable, fuel efficient, low noise, Tier-III certified Cummins QSM11 engine
Electronically controlled for optimum fuel to air ratio / Clean and efficient combustion
Self-diagnostic system
Different operation modes (Power / Standard / Economy) controlled by rotational switch

ZF Full Automatic Transmission

4 automatic modes (Manual / Light / Normal / Heavy) for various applications
Protection transmission at low temperature (with Automatic warm-up system)
Self-diagnostic & history of alarms
Smooth gear shifting by applying proportional controlling modulation valve / Self adjusting Clutch gap
Kick-down button & Forward-Neutral-Reverse switch for increased comfort

Axles

Front axle equipped with an hydraulic lockable differential for maximum traction on different ground conditions
Self-adjusting brakes, mounted in wheel hubs

High Durability

“Load sensing – Flow sharing” hydraulic system with variable displacement pump
Improved cooling system with high resistance to thermal shocks and vibrations
Steering cylinder lug & bucket link designed with reinforced and stressless cast steel

Enhanced Operator's Comfort

Improved Visibility

Enlarged cabin with curved front window
Extra visibility with additional glass in the lower door
All windows consist of Safety glass

Improved Convenience

Increased cooling & heating capacity with full automatic temperature control
Tilting & telescopic steering column and large adjustable wrist rest to meet all operator's preferences
Various storage spaces in the cab / Radio & MP3 player with USB-input
Stair with large aluminum steps for easy and safe access to the cabin

Advanced Color LCD-display

New color LCD-display with easy to read digital gauges for hydraulic oil temperature, water temperature and fuel level
Monitoring system with boom & bucket position settings and payload-system to increase work efficiency and overload prevention
Through the LCD-display, the condition of engine, transmission and other electric devices can be checked with the blink of an eye
Automatic activated rear view camera for easier and safer work
Hi-mate, Hyundai's newly developed remote management system, using GPS-satellite technology, provides our customers with the highest level of service and product support

Easy Maintenance

Reversible, hydraulic driven cooling fan for reduced fuel consumption and low noise
Ground level access of service points and sight gauges for easy maintenance
Extended life of filters & hydraulic oil

Preference

An operator, who sets his machine to his needs, takes pleasure in his work. 9 Series respects operator preference with regards to comfort, ease-of-use and controllability. The dashboard cluster with 5.7 inch screen is the preference nerve centre.



Spacious and Convenient Cab

The newly designed cabin was conceived for more space, better visibility and increased operator's comfort. The front window is curved with 17% more glass area than our previous series. Special attention was given to a clean and open interior with plenty of visibility on the machine surroundings and the jobsite. A balanced combination of cab ergonomics puts the operator in the perfect position to work safely and securely. The full automatic temperature control features 11 air vents and increased cooling and heating capacity for optimum temperature control. The defroster vents on the front and rear window and an electric pre-heater make working in cold circumstances more convenient.

*Photo may include optional equipment.

Operator Comfort

on the joystick facilitates selection of travel direction. Roll-up type sun visor on the front window and optional on the rear window allow the operator to reduce glare and to improve visibility. Heated rearview mirrors for quick defrosting during cold weather conditions.

In a 9 series cabin you can easily adjust the steering column and wrist rest to meet your preferred comfort level. A pilot-operated joystick offers high controllability of your hydraulic attachments. A Forward-Neutral-Reverse switch

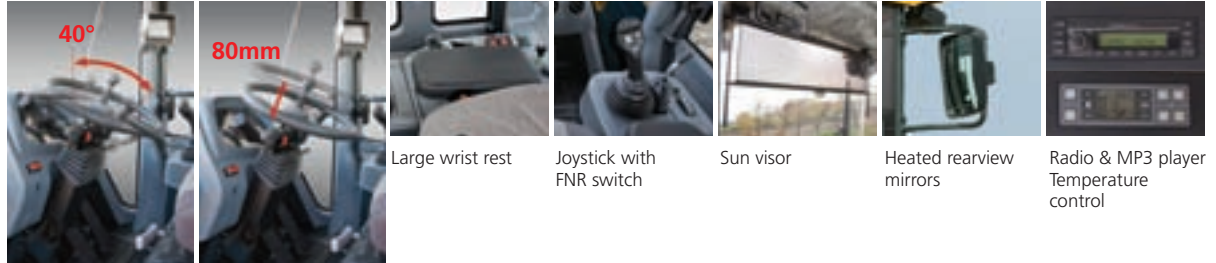

Large wrist rest

Joystick with FNR switch

Sun visor

Heated rearview mirrors

Radio & MP3 player
Temperature control

Tilting / telescopic steering column

Stressless

Work is stressful enough. Your working environment should be stressless. Hyundai's 9 series provides improved cabin interior, additional storage space and a comfortable seat to minimize the stress of the operator. A powerful climate control system provides the operator with his preferred air temperature. An advanced audio system with AM/FM stereo and MP3 player with USB input, is installed to listen to your preferred music favorites.

Advanced LCD-display



The advanced cluster with 5.7 inch wide color LCD-display allows the operator to select his personal machine preferences. The operator can preset boom kick-out and bucket-level position while monitoring the preferred settings through the monitor. An integrated payload-system (optional) gives a clear indication of your load on the monitor and contributes to higher work efficiency. Self-diagnostics, automatic activated rear-view camera, maintenance check lists and startup machine security are integrated into the monitor to make the machine more versatile and the operator more productive. The LCD-display is mounted on an adjustable swivel bracket to meet the operator's preference.

Adjustable LCD-display

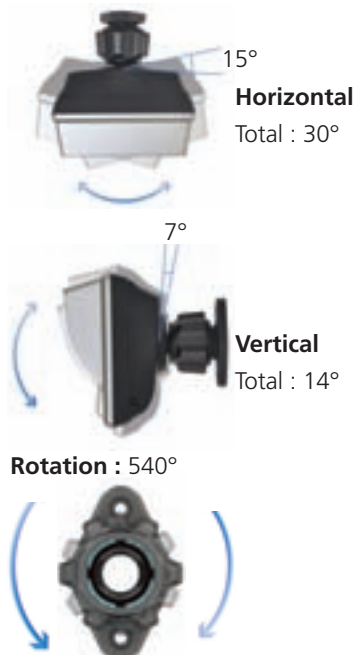

Performance

An operator, who can rely on his machine, takes pleasure in his work. 9 Series stand for lasting performance in strength, speed and reliability. The innovative hydraulic system makes the 9 Series wheel loader fast, smooth and easy to control.



*Photo may include optional equipment.

Improved Durability & Reliability



The new load sensing hydraulic system with a variable volume piston pump and closed center main control valve, provide efficient hydraulic power and additional energy savings. Completely redesigned, parallel-mounted coolers with non louvered fins make our 9 series easy to clean and easy to service. All coolers are designed with aluminum bar plate configuration and undergo extended factory tests for thermal shocks and vibrations to assure long term durability. Top mounted non-louvered aluminum air condenser and variable displacement A/C compressor are designed for maximum cooling capacity and energy savings. The redesigned steering cylinder lug and bucket link are made of cast steel for additional strength and reliability.

Various Operating Modes



9 series wheel loaders are designed to allow the operator to customize the machine's engine power, automatic transmission shift timing and clutch cut-off based on the application and operator's preference. Convenient rotational switches allow easy adjustment of engine power mode, automatic mode and clutch cut-off mode. Additionally, the 9 Series wheel loader can be equipped with an optional ride control system. The ride control system has a shock absorbing accumulator that cushions the boom cylinders, in order to improve operator's comfort and to reduce material loss. The versatility of the 9 series operating modes contributes to improved productivity, enhanced operator comfort and reduced fuel consumption.



3 Engine Power Modes

Power Mode : Heavy duty work
Standard Mode : General work
Economy Mode : Light duty work

4 Transmission Shift Modes

Manual Mode
Auto-Light Mode : Light duty & long distance carry
Auto-Normal Mode : General loading & retracting light material
Auto-Heavy Mode : Heavy duty loading & retracting heavy material

3 Clutch Cut-Off Modes

Low Mode : Short distance & fast loading
Medium Mode : General loading
High Mode : Loading on a slope



Cummins QSM11 Engine

The CUMMINS QSM11 engine combines full-authority electronic controls with reliable performance. The combination of a high pressure system and an advanced in-cylinder combustion technology results in increased power and reduced fuel consumption. To control these high-horsepower products, the QSM11 engine uses advanced electronics controls to comply with the current emissions standards including EPA Tier3 and EU Stage IIIA.



Full Automatic Transmission

A full automatic transmission is implemented for maximum durability, minimum power loss, high travel speed and low noise. Improved clutch control and fluent shifting, contribute to a smoother ride. Transmission faults are recorded and accessible through the monitor.

Profitable

An owner, who knows his machine saves money, takes pleasure in owning it. 9 Series wheel loaders contribute to your business as a time, fuel, spare-part and cost saving earthmoving solution. The Remote Management System allows machine owners to track, monitor and manage at a distance.



*Photo may include optional equipment.



Hi-mate (Remote Management System)

Hi-mate, Hyundai's newly developed remote management system, using GPS-satellite technology, provides our customers with the highest level of service and product support. Hi-mate enables machine owners to follow-up machine performance, to verify machine location and to access diagnostic information on a distance through any internet connection.



Cooling Fan integrated in Rear door

The cooling fan and fan motor are integrated into the rear door for easy access and regular maintenance. Convenient location of coolant and transmission oil gauges make checking fluid levels fast and efficient.



Hydraulic driven Cooling Fan

The remote mounted, hydraulic driven cooling fan regulates fan speed according to actual temperatures of engine coolant, air intake, transmission oil and hydraulic oil. This new fan design reduces fuel consumption and machine noise. The automatic or manual auto reverse function blows debris out of the coolers.



Easy Access

Access from ground to filters, lube fittings, fuses, drains and machine computer components, combined with wide open compartments makes servicing the 9-series a pleasure for your mechanics.



Hydraulic Oil filter
(1,000 hr)



Hydraulic Oil
(5,000 hr)

Extended Life of Components

9 series machines are designed for extended lubrication intervals and life of components. Long life hydraulic filters last up to 1,000 hrs and Hyundai certified "long-life hydraulic oil" only needs to be changed every 5,000 hrs. Also, a new center pivot roller bearing, now double tapered, requires less maintenance. Long life and extended wear components save time and money for machine owners.

Specifications

ENGINE

Maker/Model	CUMMINS QSM11
Type	4-cycle, turbocharged, charge air-cooled direct injection, electronic controlled diesel engine
Gross power	348 HP (260 kW) / 2,000 rpm
Net power	344 HP (257 kW) / 2,000 rpm
Maximum torque	171 kg.m (1,235 lb.ft) / 1,400 rpm
No. of cylinders	6

Bore x Stroke	125 mm (4.9") x 147 mm (5.8")
Displacement	10.8 l (660 cu in)
Compression ratio	16.3 : 1
Air cleaner	Dry, dual elements
Alternator	24 V; 70 Amp
Battery	2 x 12 V, 220 Ah.
Starting motor	24 V; 7.5 kW

※ No derating for continuous operating required up to 3,048 m (10,000 ft). This engine meets the EPA (Tier III) / EU (Stage III-A) Emission regulation.

TRANSMISSION

Torque converter type	3-elements, single-stage Double-phase
------------------------------	--

※ Full automatic power shift, countershaft type with soft-shift in range and direction. Properly matched torque converter to engine and transmission for excellent working ability.

		km/h (mph)
Forward	1st	6.1 (3.8)
	2nd	11.5 (7.1)
	3rd	18.0 (11.2)
	4th	36.5 (22.7)
Reverse	1st	6.1 (3.8)
	2nd	11.5 (7.1)
	3rd	25.0 (15.5)

AXLES

Drive system	Four-wheel drive system
Mount	Rigid front axle and oscillating rear axle
Rear axle oscillation	+/- 13° (total 26°)

Hub reduction	Planetary reduction at wheel end
Differential	Front: Hydr. lockable Rear: Conventional
Reduction ratio	27.0

HYDRAULIC SYSTEM

Type	Load-sensing hydraulic system
Pump	Variable axial piston type, max. 420 l/min (111.0 gal/min) @ governed rpm
Control valve	2 spool (Bucket, Boom) 3 spool (Bucket, Boom, Aux) Pilot – operated Joystick
System pressure	280 kgf/cm ² (3,982 psi)

Bucket Controls	Type	Pilot operated lift and tilt circuit, single-lever joystick control standard.
	Lift Circuit	The valve has four functions: raise, hold, lower and float. An adjustment for automatic kick-out from horizontal to full lift is installed.
	Tilt Circuit	The valve has three functions: tilt back, hold and dump. An adjustment for automatic bucket position to the preferred load angle is installed.
Cylinders		Type : Double acting Lift, bore x stroke 2-180 mm (7.0") x 863 mm (34.0") Tilt, bore x stroke 2-140 mm (5.5") x 575 mm (22.6") 2-140 mm (5.5") x 570 mm (25.4")
Cycle Time		Raise (with load) : 6.1 sec Dump : 1.4 sec Lower (empty) : 4.1 sec Total : 11.6 sec

BRAKES

Service Brakes	Hydraulic actuated, wet disc brakes on all wheels Independent axle-by-axle Self adjusting & integrated in wheel hub
Parking Brake	Spring-applied, hydraulic released, on front axle input shaft
Emergency Brake	When brake oil pressure drops, indicator light alerts operator and parking brake automatically applies.

STEERING SYSTEM

Type	Load-sensing hydrostatic articulated steering	
Pump	Piston pump, max. 220 l/min (58.1 gal/min) @ governed rpm	
Relief Valve Setting	210 kg/cm ² (2,990 psi)	
Cylinder	Type	Double acting
	Bore x Stroke	105 mm (4.1") x 480 mm (18.9")
Steering Angle	40° (each direction)	

Features - Center-point frame articulation.
- Load-sensing, pressure-compensated system.
- Steering-wheel operated metering pump controls flow to steering cylinders.
- Tilt and telescopic steering column.

SERVICE REFILL CAPACITIES

Fuel tank	450 liters (118.8 US gal)
Cooling system	65 liters (17.2 US gal)
Crankcase	38 liters (10.0 US gal)
Transmission	43 liters (11.4 US gal)

Front axle	58 liters (15.3 US gal)
Rear axle	58 liters (15.3 US gal)
Hydraulic tank	234 liters (62 US gal)
Hydraulic system (including tank)	344 liters (90.8 US gal)

OVERVIEW

Description	UNIT	HL780-9	HL780XTD-9
Operating weight	kg (lb)	30,000 (66,100)	30,800 (67,900)
Bucket Capacity	Heaped	m ³ (yd ³)	5.4 (7.1)
	Struck	m ³ (yd ³)	4.6 (6.0)
Breakout force-bucket	kg (lb)	23,750 (52,360)	23,130 (50,990)
Tipping load	Straight	kg (lb)	24,200 (53,350)
	Full turn	kg (lb)	21,000 (46,300)

TIRES

Type	Tubeless, loader design tires
Standard	29.5-25, 22 PR, L3
Options include	26.5-25, 32 PR, L3 29.5-25, 28 PR, L3 29.5-25, 28 PR, L5 29.5 R25 XHA*

DIMENSIONS

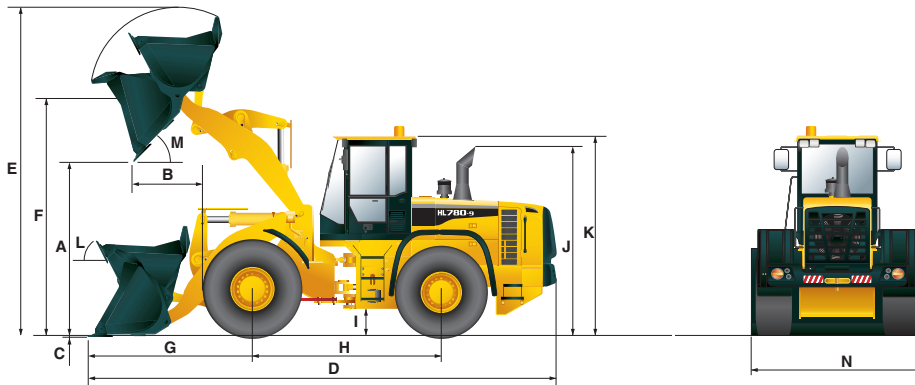

Description	UNIT	HL780-9	HL780XTD-9
Bucket Type	General purpose bolt-on cutting edge		
A. Dumping clearance at max. height and 45° dump angle.	mm (ft-in)	3,300 (10' 10")	3,670 (12')
B. Reach	full lift	mm (ft-in)	1,430 (4' 8")
	7ft height	mm (in)	2,150 (7' 1")
C. Digging depth	mm (ft-in)	105 (4.1")	115 (4.5")
D. Overall length	on ground	mm (ft-in)	9,630 (31' 7")
	at carry	mm (ft-in)	9,545 (31' 4")
E. Overall height (fully raised)	mm (ft-in)	6,295 (20' 8")	6,670 (21' 11")
F. Bucket pivot max. height	mm (ft-in)	4,560 (15')	4,935 (16' 2")

Description	UNIT	HL780-9	HL780XTD-9
G. Front overhang	mm (ft-in)	3,200 (10' 6")	3,575 (11' 9")
H. Wheelbase	mm (ft-in)	3,700 (12' 2")	3,700 (12' 2")
I. Ground clearance	mm (ft-in)	495 (1' 7")	495 (1' 7")
J. Height over exhaust	mm (ft-in)	3,310 (10' 10")	3,310 (10' 10")
K. Height over cab	mm (ft-in)	3,865 (12' 8")	3,865 (12' 8")
L. Roll-back angle	on ground	deg	42
	at carry	deg	48
M. Dump angle	deg	47	47
Clearance circle	mm (ft-in)	14,970 (49' 1")	15,310 (50' 3")
N. Overall width	with bucket	mm (ft-in)	3,450 (11' 4")
	without bucket	mm (ft-in)	3,220 (10' 7")

BUCKET SELECTION GUIDE

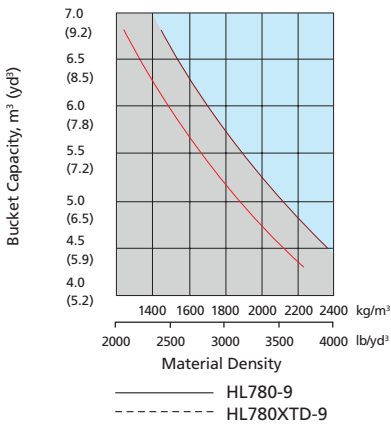

SUPPLEMENTAL SPECIFICATIONS

Description	Change in operating weight kg (lb)	Change in static tipping load-straight kg (lb)	Change in static tipping load-40° turn kg (lb)
26.5-25 32PR L3	-112 (-247)	-90 (-200)	-80 (-175)
29.5-25 28PR L3	+352 (+776)	+270 (+595)	+240 (+530)
29.5-25 28PR L5	+1,240 (+2,734)	+960 (+2,160)	+850 (+1,870)
29.5 R25 XHA*	+500 (+1,102)	+390 (+860)	+340 (+750)

STANDARD EQUIPMENT

Electrical system

- Alternator, 70A
- Alarms, audible and visual
 - air filter clogging
 - transmission error
 - alternator voltage
 - brake oil pressure
 - engine oil pressure
 - parking brake
 - fuel level
 - hydraulic oil temperature
 - coolant temperature
 - service brake oil pressure
- Back-up Alarm
- Batteries, 1,315 CCA, 12V, (2)
- Gauges
 - engine coolant temperature
 - fuel level
 - hydraulic oil temperature
 - speedometer
 - transmission oil temperature
 - voltmeter
- Horn, electric
- Indicator lights
 - clutch cut-off
 - high beam
 - turn signal
 - working lights
- LCD Display
 - clock and fault code
 - operating hours
 - engine rpm

- transmission gear indicator
- job time and distance
- temperature (coolant, hydraulic oil, T/M oil)
- Lighting system
 - 2 LED dome lights
 - 2 stop and tail lights
 - 4 turn signals
 - brake lights (counterweight)
 - 2 head lights on front chassis
 - 2 working lights on cabin roof (front)
 - 2 working lights in grill
- Switches
 - clutch cut-off
 - hazard
 - Ignition key, start/stop switch
 - main lights (working and head lights)
 - parking brake
 - rear wiper & washer
 - battery master switch
 - pilot-system cut-off
- Starter, electric
- Starting and charging system (24-volt)
- Cab**
 - Cab, ROPS (ISO3471) / FOPS (ISO3449) (sound suppressed and pressurized) with :
 - cigar lighter & ashtray
 - coat hook

- Automatic temperature control
 - air conditioner & heater
 - defroster
 - intermittent wiper and washer, front and rear
- Personal storage space:
 - console box
 - holder, can and cup
- Rear view mirrors (2 inside)
- Rear view mirrors (2 outside)
- 2" retractable seat belt & adjustable suspension seat with armrests
- Tilt / telescopic steering column
- Steering wheel with knob
- Roll-up type sun visor (front window)
- Tinted safety glass
- Cabin with two doors
- Magazine pocket
- Pedals
 - one accelerator pedal
 - one brake pedal
- Rubber floor mat
- Wrist rest
- Radio/USB player
- Engine**
 - Antifreeze
 - Engine, Cummins QSM11
 - low Emission Diesel, Tier-III
 - 3 operating modes
 - power/standard/economy
 - Engine doors, lockable
 - Engine fuel priming pump

- Fan guard
- Fuel/water separator
- Fuel warmer
- Muffler, under hood with large exhaust stack
- Rain cap, engine air intake
- Radiator
- Starting aid (air intake heater)
- Power Train**
 - Brakes : Service, enclosed wet-disc
 - Front Differential: Hydraulic lockable
 - Rear Differential : Conventional
 - Parking brake
 - Torque converter
 - Transmission, computer-controlled, electronic soft shift, auto-shift and kick down features included
 - Transmission oil cooler
- Hydraulics**
 - Automatic boom kickout
 - Automatic bucket positioner
 - Wrist rest
 - Diagnostic pressure taps
 - Hydraulic oil cooler
 - Hydraulic system,
 - 2 spool, single lever, pilot control for boom and bucket actuation
 - Steering, load-sensing
 - Remote cooling fan, hydraulically-driven, temperature sensing type
- Others**
 - Articulation locking bar

- Coolant level sight gauge
- Counterweight
- Door and cab locks, one key fits all
- Doors, service access(locking)
- Drawbar with pin
- Engine oil level dipstick gauge
- Ergonomically located and slip resistant, left & right
 - handrails
 - ladders
 - platforms
 - steps
- Fenders (front)
- Guard, bucket cylinder rod
- Hydraulic oil level sight gauge
- License plate bracket
- Lift and tie-down hooks
- Loader linkage, sealed Z-Bar design
- Cushioned steering stops
- Tires (29.5-25, 22PR,L3)
- Transmission oil site level
- Vandalism protection cap locks

OPTIONAL EQUIPMENT

- 24-volt to 12-volt DC converter
- 3 Spool
- Climate control :
 - air conditioner only
 - heater only
- Beacon light
- Auxiliary, 2 working lights on front roof (Xenon working lights)
- Auxiliary, 2 working lights on rear roof

- Cutting edge, bolt-on type
- Dual brake pedal
- Joystick steering system
- Fire extinguisher
- High lift arrangement with additional counterweight, 552 kg (1,210 lb)
- Hydraulic control, 2 lever
- Hydraulic control, 3 lever
- 3rd spool for auxiliary function

- Joystick with travel switch (FNR)
- Operator suit
- Pallet forks
- Ride control system
- Heated rear view mirrors (2 outside)
- Reversible cooling fan
- Seat
 - 2" static seat belt & adjustable mechanical suspension(vinyl)
 - 3" static seat belt & adjustable

- mechanical suspension
 - 2" retractable seat belt & adjustable air suspension (heated)
- Tires :
 - 29.5 - 25, 28PR L3
 - 29.5 - 25, 28PR L5
 - 26.5 - 25, 32PR L3
 - 29.5 R25 XHA*
- Tool kit
- Tooth, 2 pieces, bolt-on type

- Wheel chock
- Hi-Mate (Remote Management System)
- Rear view camera
- Dual-brake pedal
- Roll-up type sun visor (rear window)
- License plate & lamp
- Pre-cleaner engine air intake

Standard and optional equipment may vary. Contact your Hyundai dealer for more information. The machine may vary according to International standards. All imperial measurements rounded off to the nearest pound or inch.

PLEASE CONTACT

