



# 815

## Soil Compactor

# Technical Specifications

Configurations and features may vary by region. Please consult your Cat® dealer for availability in your area.

## Table of Contents

<b>Specifications</b> .....	<b>2</b>
Engine .....	2
Operating Specifications .....	2
Transmission .....	2
Hydraulic System Lift/Tilt .....	2
Hydraulic System - Steering .....	2
Service Refill Capacities .....	2
Axles .....	3
Brakes .....	3
Sound Performance .....	3
Blades .....	3
Wheels .....	3
Dimensions .....	4
<b>Standard and Optional Equipment</b> .....	<b>5</b>

# 815 Soil Compactor Specifications

## Engine

Engine Model	Cat C7.1	
Emissions	<b>U.S. EPA Tier 4 Final/EU Stage V</b>	
Rated Speed	2,200 rpm	
Net Power (SAE J1349:2011)	186 kW	249 hp
Net Power (ISO 9249:2007)	186 kW	249 hp
Gross Power (SAE J1995:2014)	212 kW	284 hp
Engine Power (ISO 14396:2002)	205 kW	275 hp
Peak Torque @ 1400 rpm	1223 N·m	902 lbf-ft
Torque Rise	52%	

- Net power available at flywheel when the engine is equipped with fan, air cleaner, aftertreatment, and alternator with engine speed at 2,200 rpm.

Emissions	<b>Brazil MAR-1 and China Nonroad Stage III, equivalent to U.S. EPA Tier 3/EU Stage IIIA</b>	
Rated Speed	2,200 rpm	
Net Power (SAE J1349:2011)	186 kW	249 hp
Net Power (ISO 9249:2007)	186 kW	249 hp
Gross Power (SAE J1995:2014)	213 kW	286 hp
Engine Power (ISO 14396:2002)	205 kW	275 hp
Peak Torque @ 1400 rpm	1016 N·m	749 lbf-ft
Torque Rise	26%	

- Net power available at the flywheel when the engine is equipped with fan, air cleaner, muffler, and alternator with engine speed at 2,200 rpm.

Bore	105 mm	4.1 in
Stroke	135 mm	5.3 in
Displacement	7.01 L	427.8 in <sup>3</sup>
High Idle Speed	2,270 rpm	
Low Idle Speed	800 rpm	
Maximum Altitude without Derating	3000 m	9,842.5 ft

## Operating Specifications

Operating Weight (Tier 4 Final/Stage V)	22 522 kg	49,652 lb
Operating Weight (Tier 3/Stage IIIA equivalent)	22 232 kg	49,013 lb

## Transmission

Transmission Type	Cat Planetary Power Shift	
Forward – First	6.3 km/h	3.9 mph
Forward – Second	10.8 km/h	6.7 mph
Forward – Third	18.2 km/h	11.3 mph
Reverse – First	7.2 km/h	4.5 mph
Reverse – Second	12.4 km/h	7.7 mph
Reverse – Third	18.4 km/h	11.4 mph

## Hydraulic System Lift/Tilt

Lift/Tilt System – Circuit	Pilot Operated LS Valve with EH	
Lift/Tilt System	Variable Displacement Piston	
Max Flow at 2,200 rpm	89 L/min	23.5 gal/min
Relief Valve Setting – Lift/Tilt	22 000 kPa	3,190 psi
Cylinders, Double Acting: Lift, Bore, Stroke	101.6 mm × 627 mm	4.0 in × 24.7 in
Cylinders, Double Acting: Left and Right Tilt, Bore, Stroke	101.6 mm × 167 mm	4.0 in × 6.6 in
Pilot System	Open Center, Fixed Displacement Gear	
Pilot Relief Valve Setting	21 000 kPa	3,046 psi

## Hydraulic System - Steering

Steering System- Circuit	Pilot, Load Sensing	
Steering System- Pump	Variable Displacement Piston	
Max Flow @ 2,200 rpm	147 L/min	38.8 gal/min
Relief Valve Setting - Steering	27 600 kPa	4,003 psi
Total Steering Angle	84°	
Steering Cycle Time (high idle)	3.0 sec	
Steering Cycle Time (low idle)	8.2 sec	

## Service Refill Capacities

Fuel Tank	500 L	132.1 gal
Diesel Exhaust Fluid Tank	16 L	4.2 gal
Cooling Systems - Tier 4 Final/Stage V	81 L	21.4 gal
Cooling Systems - Tier3/Stage IIIA equivalent	73 L	19.3 gal
Engine Crankcase	20 L	5.3 gal
Transmission	56 L	14.8 gal
Differentials and Final Drives - Front	65 L	17.2 gal
Differentials and Final Drives - Rear	65 L	17.2 gal
Hydraulic System - Implement/Steering	175 L	46.2 gal
Hydraulic Tank Only	75 L	19.8 gal

- All nonroad Tier 4 Final and Stage V diesel engines are required to use:
  - Ultra Low Sulfur Diesel (ULSD) fuels containing 15 ppm for EPA and 10 ppm for EU (mg/kg) sulfur or less. Biodiesel blends up to B20 are acceptable when blended with 15 ppm (mg/kg) sulfur or less ULSD and when the biodiesel feedstock meets ASTM D7467 specifications.
  - Cat DEO-ULS™ or oils that meet the Cat ECF-3, API CJ-4, and ACEA E9 specifications are required.
  - Diesel Exhaust Fluid (DEF) that meets all requirements defined in ISO 22241-1:2006.

# 815 Soil Compactor Specifications

## Axles

Front	Planetary – Fixed
Rear	Planetary – Oscillating
Oscillation Angle	±10°

## Brakes

Service Brakes	Single Disc Wet (Enclosed) 2 WHL
Parking Brake	Drum and Shoe, Spring Applied, Hydraulic Released

## Sound Performance

	Standard	Suppression	Suppression EU
--	----------	-------------	-------------------

Operator Sound Level (ISO 6396:2008)		70 dBA	
-----------------------------------------	--	--------	--

### Tier 4 Final/Stage V

Machine Sound Level (ISO 6395:2008)	111 dBA	109 dBA	
Machine Sound Level (ISO 6393:2008)			107 dBA

### Brazil MAR-1 and China Nonroad Stage III, equivalent to Tier 3/Stage IIIA

Machine Sound Level (ISO 6395:2008)	112 dBA	110 dBA	
----------------------------------------	---------	---------	--

- The operator sound pressure level was measured according to the test procedures and conditions specified in ISO 6396:2008. The measurement was conducted at the maximum engine cooling fan speed.
- The operator sound pressure level uncertainty is ± 2 dB(A)
- Hearing protection may be needed when the machine is operated with a cab that is not properly maintained or when the doors or windows are open for extended periods or in a noisy environment.
- The machine sound power level was measured according to the test procedures and conditions specified in ISO 6395:2008. The measurement was conducted at the maximum engine cooling fan speed.
- The machine sound power level was measured according to the test procedures and conditions specified in ISO 6393:2008. The measurement was conducted at the rated engine cooling fan speed.

## Blades

### Straight Blade

Capacity	2.06 m <sup>3</sup>	2.69 yd <sup>3</sup>
Overall Width	3761 mm	12.3 ft
Height	860 mm	2.8 ft
Digging Depth	222 mm	0.7 ft
Ground Clearance	802 mm	2.6 ft
Maximum Tilt	346 mm	1.1 ft
Turning Radius - Outside Corner of Blade	6437 mm	21.1 ft
Turning Radius - Inside Face of Pusharm	2520 mm	8.3 ft
Weight	800 kg	1,764 lb
Total Operating Weight	22 522 kg	49,652 lb

## Wheels

### Tamping Foot

Weight (Group)	4409 kg	9,720 lb
Outside Diameter	1412 mm	55.6 in
Drum Diameter	1029 mm	40.5 in
Drum Width	991 mm	39.0 in
Feet per Row		12
Feet per Wheel		60
Replaceable		Weld On
Width Over Drums	3243 mm	127.7 in
Width Between Drums	1261 mm	49.6 in
Tip Height	192 mm	7.5 in

# 815 Soil Compactor Specifications

## Dimensions

All dimensions are approximate.

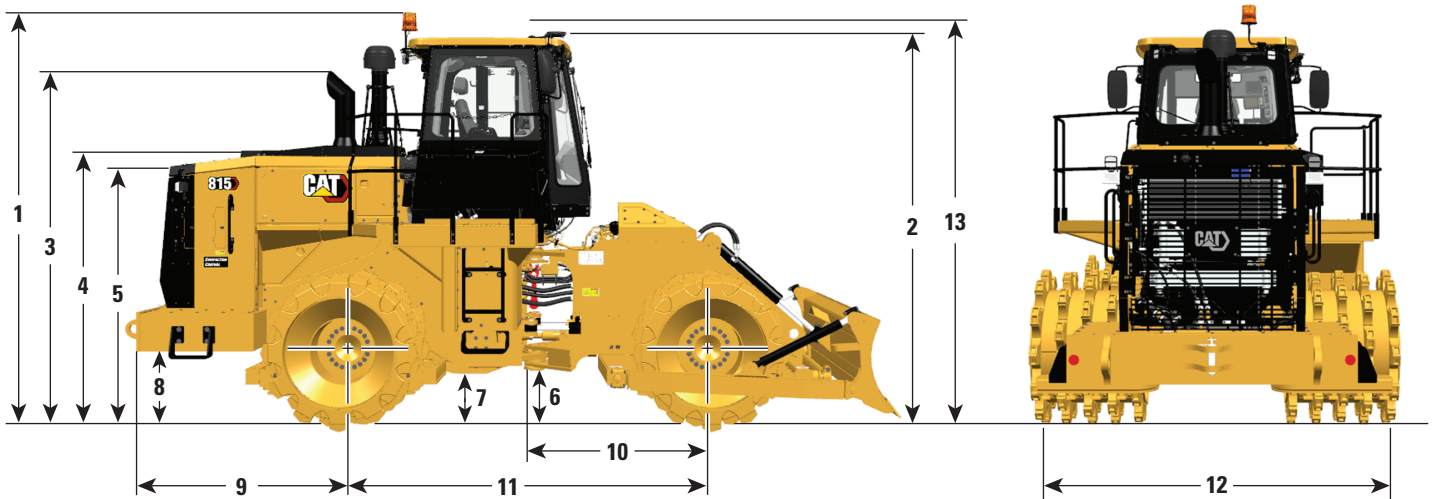

1	Height to Top of Beacon	3933 mm	12.9 ft
2	Height to Top of Cab Roof	3650 mm	12.0 ft
3	Height to Top of Exhaust Pipe	3394 mm	11.1 ft
4	Height to Top of Hood	2616 mm	8.6 ft
5	Height to Top of Radiator Guard	2405 mm	7.9 ft
6	Ground Clearance to Hitch	365 mm	1.2 ft
7	Ground Clearance to XMSN Guard	375 mm	1.2 ft
8	Ground Clearance to Bottom of Bumper	665 mm	2.2 ft
9	Center Line of Rear Axle to Bumper	1990 mm	6.5 ft
10	Center Line of Front Axle to Hitch	1675 mm	5.5 ft
11	Wheelbase	3350 mm	11.0 ft
12	Width Over Platform	3140 mm	10.3 ft
13	Height to Top of GPS Antenna	3701 mm	12.1 ft

# 815 Soil Compactor Standard and Optional Equipment

## Standard and Optional Equipment

Standard and optional equipment may vary. Consult your Cat dealer for details.

	Standard	Optional		Standard	Optional
<b>POWER TRAIN</b>			<b>OPERATOR ENVIRONMENT (CONTINUED)</b>		
Advanced Productivity Electronic Control System (APECS)	✓		Air conditioner	✓	
Air-to-air aftercooler	✓		Cab, sound-suppressed pressurized	✓	
Axles – standard or non-spin rear		✓	Cab door, sliding window (LH)	✓	
Brakes, full hydraulic, enclosed, wet multiple disc service brakes	✓		Camera, rear vision	✓	
Cat clean emission module (Tier 4 Final/Stage V only)	✓		Cat Compaction Control (ready)	✓	
Electro hydraulic parking brake	✓		Cat Detect: object detection (ready)	✓	
Electronic Clutch Pressure Control (ECPC)	✓		Coat and hard hat hooks	✓	
Engine, Cat C7.1 configured for two emissions options: Tier 4 Final/Stage V or Tier 3/Stage IIIA equivalent	✓		Fingertip shifting controls	✓	
Engine driven cooling fan – suction	✓		Flip-up armrest	✓	
Fuel priming pump (electric)	✓		Glass (window) – rubber-mounted glass	✓	
Fuel-to-air cooler	✓		Heater and defroster	✓	
Ground level engine shutoff	✓		Horn, electric	✓	
Heater, engine coolant, 120V		✓	Hydraulic controls – seat mounted	✓	
Heater, engine coolant, 240V		✓	Implement hydraulic lockout	✓	
Muffler under hood (Tier 3/Stage IIIA equivalent only)	✓		Instrumentation, gauges: DEF fluid level (Tier 4 Final/Stage V only), engine coolant temperature, fuel level, hydraulic oil temperature, speedometer/tachometer, torque converter temperature	✓	
Radiator, unit core	✓		Instrumentation, warning indicators: action alert system – three categories, brake oil pressure, electrical system – low voltage, engine failure malfunction alert and action lamp, parking brake status	✓	
Starting aid (ether)	✓		Light, cab, dome	✓	
Throttle lock	✓		Lunchbox and beverage holders	✓	
Torque converter	✓		Mirrors (cab) – standard or heated		✓
Transmission, planetary, with 3F/3R speed range control	✓		Mirror, internal (panoramic)	✓	
<b>ELECTRICAL</b>			Mirrors, rearview (externally mounted)	✓	
Alarm, back-up	✓		Precleaner (cab) – powered	✓	
Alternator, 150 amp	✓		Radio, AM/FM/Aux/USB/Bluetooth		✓
Batteries, maintenance-free	✓		Radio, CB (ready)		✓
Electrical system, 24V	✓		Radio ready for entertainment: antenna, speakers, converter (12V, 10-15 amp)	✓	
Ground level lockable master disconnect switch	✓		Seat, Cat Premium Plus (leather)	✓	
Lights, directional (rear)	✓		Seat (cab) – heated and ventilated	✓	
Lights, standard or LED		✓	Seat belt with minder, retractable, 76 mm (3 in) wide	✓	
Lights, warning switched (LED strobe)	✓		STIC™ control system with lockout	✓	
Lighting system (front and rear)	✓		Sun visor, front	✓	
Starter, electric	✓		Tinted glass	✓	
Starting receptacle for emergency start	✓		Transmission gear (indicator)	✓	
<b>OPERATOR ENVIRONMENT</b>					
12V power port for mobile phone or laptop connection	✓				
AccuGrade™ mapping (ready)	✓				

# 815 Soil Compactor Standard and Optional Equipment

## Standard and Optional Equipment

Standard and optional equipment may vary. Consult your Cat dealer for details.

	Standard	Optional		Standard	Optional
<b>OPERATOR ENVIRONMENT (CONTINUED)</b>			<b>OTHER STANDARD EQUIPMENT</b>		
Vital Information Management System (VIMS™): graphical information display, external data port, customizable operator profiles, event indicator light on rear grill	✓		Steering, load sensing	✓	
Wet-arm wipers/washers (front and rear): intermittent wipers (front and rear)	✓		Total hydraulic filtration system	✓	
<b>TIRES, RIMS AND WHEELS</b>			Vandalism protection caplocks	✓	
Wheels, tamping foot	✓		Venturi stack	✓	
<b>GUARDS</b>			<b>TECHNOLOGY PRODUCTS</b>		
Cleaner bars with teeth	✓		Compaction control, basic		✓
Guards, crankcase and power train	✓		Product Link™ – GSM, satellite		✓
Guard, driveshaft	✓		<b>OTHER ATTACHMENTS</b>		
<b>FLUIDS</b>			Sound suppression (required for Brazil)		✓
Antifreeze, -50° C (-58° F)		✓	<b>MISCELLANEOUS</b>		
Antifreeze, premixed 50% concentration extended life (-34° C/-29° F)	✓		Film (ANSI) (Tier 4 Final/Stage V only)		✓
<b>OTHER STANDARD EQUIPMENT</b>			EU certification (Tier 4 Final/Stage V only)		✓
DEF tank fill gauge	✓		Plate – year of manufacture Tier 3/Stage IIIA equivalent only)		✓
Doors, service access (locking)	✓		<b>HYDRAULICS</b>		
Ecology drains for engine, radiator, transmission, hydraulic tank	✓		Hydraulics: Standard or EU and Canada	✓	
Engine, crankcase, 500 hour interval with CJ-4 oil	✓		<b>SPECIAL ARRANGEMENTS</b>		
Emergency platform egress	✓		Engine precleaners – turbine or dual stage		✓
Fire suppression ready	✓		<b>FUEL SYSTEMS</b>		
Fuel tank, 500 L (132.1 gal)	✓		Fuel tank – non-fast or fast fill		✓
Hitch, drawbar with pin	✓		<b>CLEANER BARS</b>		
Hoses, Cat XT™	✓		Standard or abrasive		✓
Hydraulic, engine, and transmission oil coolers	✓		<b>BLADES</b>		
Oil change system, high speed	✓		Straight or tilt-straight		✓
Oil sampling valves	✓				



For more complete information on Cat products, dealer services, and industry solutions, visit us on the web at [www.cat.com](http://www.cat.com).

AEXQ2937-00 (10-2020)  
Build Number: 11A  
Global

Materials and specifications are subject to change without notice. Featured machines in photos may include additional equipment. See your Cat dealer for available options.

© 2020 Caterpillar. All Rights Reserved. CAT, CATERPILLAR, LET'S DO THE WORK, their respective logos, DEO-ULS, AccuGrade, VIMS, Product Link, XT, STIC, "Caterpillar Corporate Yellow", the "Power Edge" and Cat "Modern Hex" trade dress as well as corporate and product identity used herein, are trademarks of Caterpillar and may not be used without permission.

