

8105

Wheel Loaders 1.0 - 1.5 m³



The elite among wheel loaders

The wheel loaders of the 80-series by Kramer set high standards in terms of technology, performance and comfort. Other plus points are versatility in use, optimal power to weight ratio and exceptional performance statistics.

- One-piece frame and all-wheel steering
- Hydraulic quick coupler system and parallel-controlled loading system
- Particularly spacious panoramic cab with the highest level of operator comfort
- Efficient drive and low operating costs
- Variety of options for a large range of uses

8105

Wheel Loaders 1.0 - 1.5 m³

Technical specifications

Operating data

Bucket capacity (standard bucket)	1,05 m ³
Operating weight	5.650 kg

Engine / Motor

Engine / Motor manufacturer	Deutz
Engine performance (standard)	55,4 kW
Engine performance (optional)	74,4 kW

Power transmission

Travel speed (standard)	20 km/h
Travel speed (optional)	40 km/h
Differential lock	100% connectable
Standard tires	14.5-20

Steering and operating hydraulics

Flow rate (pump)	84 l/min
Pressure (maximum)	240 bar
Flow rate (optional)	120 l/min

Kinematics

Tipping load (with bucket)	4.100 kg
Payload (S=1.25)	2.500 kg

Additional technical data is available in the detailed brochure in the informational material section

Dimensions

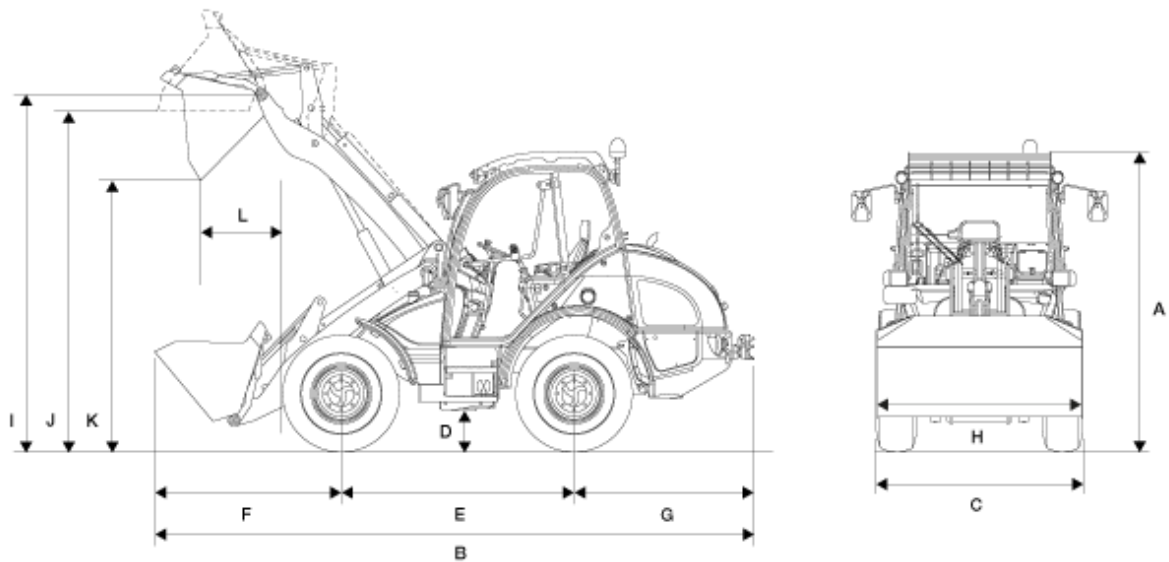

A	Height	2.640 mm
B	Length	5.710 mm
C	Width	1.920 mm
D	Ground clearance	350 mm
E	Wheelbase	2.150 mm
F	Center of front axle to tip of teeth	1.940 mm
G	Center of rear axle to end of vehicle	1.620 mm
H	Bucket width	2.050 mm
I	Bucket pivot point	3.285 mm
J	Overhead loading height	3.050 mm
K	Dumping height	2.500 mm
L	Dump reach	750 mm
	Stack height	3.000 mm

Turning radius (over tyres)

2.950 mm

Information on suitable accessories can be found on our website.

The right to make changes is reserved in the interests of ongoing further developments. You can find more information on the engine power in the operator's manual. The actual power output figures may vary due to specific operating conditions.

Information on suitable accessories can be found on our website. More detailed information on engine power can be found in the operator's manual; the stated power may vary due to specific operating conditions. Subject to alterations and errors excepted. Applicable also to illustrations. Copyright © 2015 Kramer-Werke GmbH.