

SENEBOGEN



128 kW



40 t



43 m



MAX CAB

643 M

Teleskopkran
Telescopic Crane



Zentrale Messpunkte zur einfachen und schnellen Überprüfung der gesamten Hydraulikanlage

Central measuring points for simple and quick inspection of the entire hydraulic system



Unterwagen - neue überlegene Konstruktion, neueste HD-Achsenteknik
Undercarriage - completely redesigned construction, latest HD axle technology

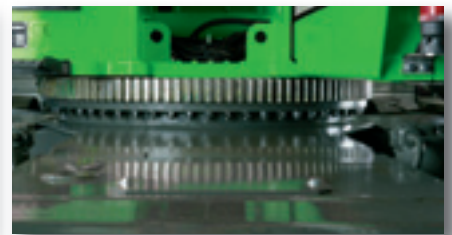

Starker, dynamischer Drehantrieb für schnelle Arbeitsspiele
Strong, dynamic swing drive for fast working cycles

The new dimension of lifting

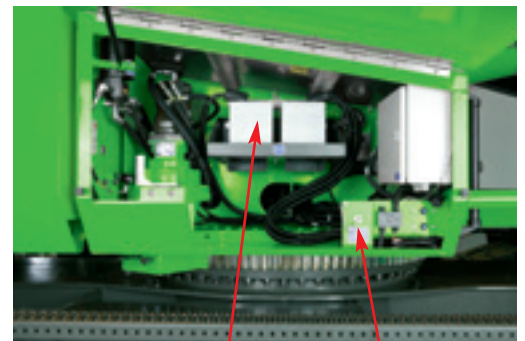

Batterie
Hervorragende Zugänglichkeit zu den Batterien
Battery
Excellent access to the batteries

Batterietrennschalter und Hauptsicherungen
Battery main switch and main fuses



Die Kühlbox mit 3-Kreis-Kühlsystem für Ladeluft-, Wasser- und Ölkühlung
The cool box with 3-circuit cooling system for charge air, water and oil cooling

Servicefreundlich

Täglicher Service bequem und schnell vom Boden aus

Service friendly

Daily service comfortable and fast from the ground



Übersichtlicher Elektroverteiler mit klarer und deutlicher Beschriftung – leichte und schnelle Fehlerdiagnose
Clearly organised electrical distribution with distinct labeling - easy and quick trouble shooting



Täglicher Service bequem und schnell vom Boden aus
Daily service comfortable and fast from the ground

Kühlbox

Die Kühler sind nebeneinander Side by Side angeordnet – keine Verschmutzung zwischen den Kühlern

Cool box

Radiators are arranged side by side - no contamination between the radiators

SENNEBOGEN HydroClean

schützt die Hydraulikkomponenten - senkt Wartungs- und Reparaturkosten

SENNEBOGEN HydroClean

protects the hydraulic components, reduces maintenance and repair costs

Starker 6-Zylinder Diesel-Motor mit 128 kW in TIER III Technologie

Strong 6-cylinder diesel engine with 128 kW in TIER III technology

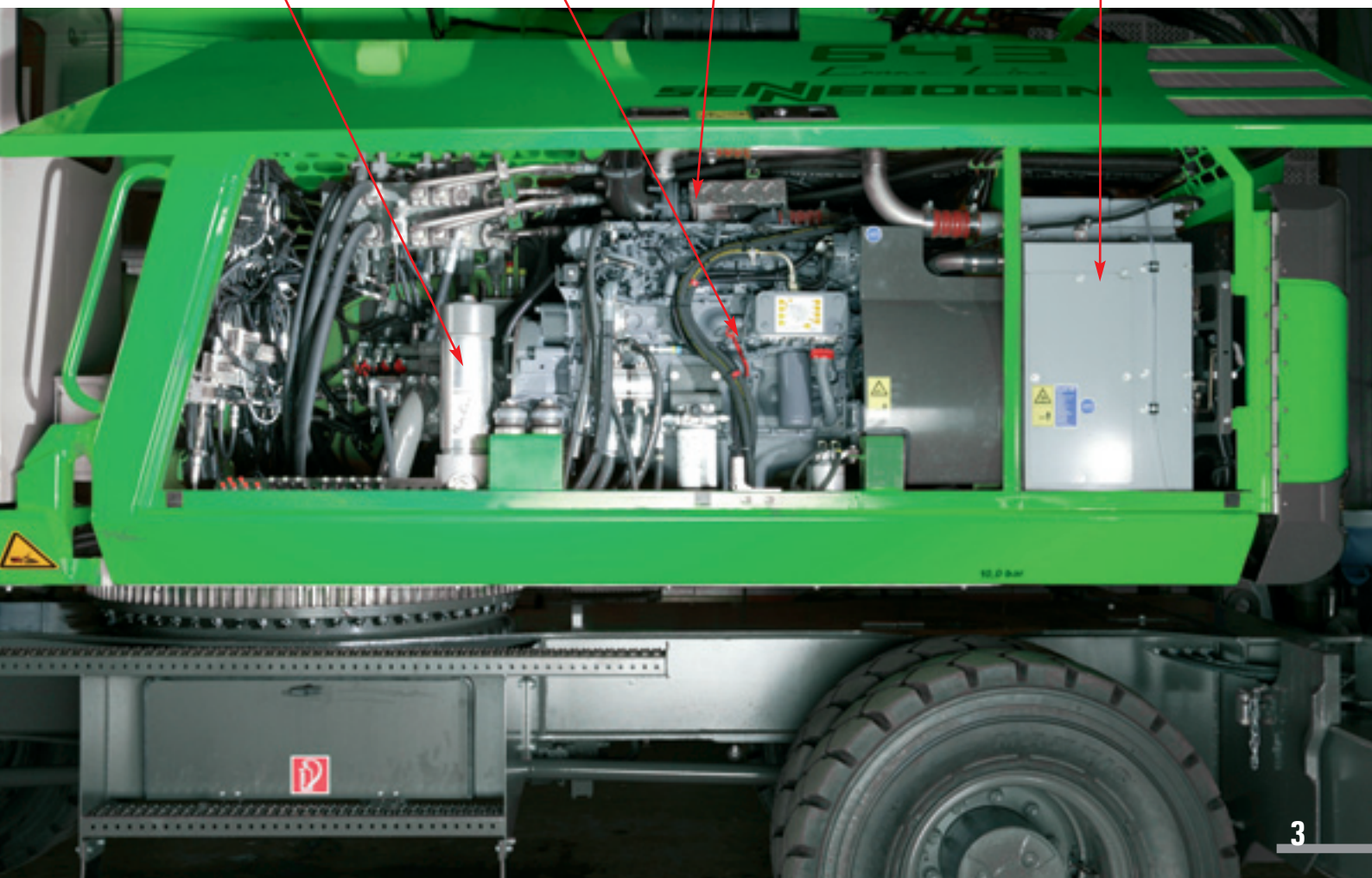

Technische Daten

Diesel-Motor

Leistung	128 kW/174 PS bei 2000 min⁻¹
Model	Deutz TCD 2012 L06 2V- TIER III
Direkteinspritzung, turboaufgeladen, Ladeluftkühlung, emissionsreduziert	
Kühlung	wassergekühlt
Luftfilter	Trockenfilter mit Vorabscheider, automatischer Staubaustrag, Haupt- und Sicherheitselement, Verschmutzungsanzeige
Kraftstofftankinhalt	300 l
Elektrische Anlage	24 V
Batterien	2 x 110 Ah, Hauptschalter

Hydraulik-System

Load Sensing/LUDV Hydrauliksystem für Arbeitsfunktionen und Fahrfunktion

Pumpentyp	Verstell-Kolbenpumpe in Schrägscheibenbauart Lastdruckunabhängige Volumensteuerung für gleichzeitige, unabhängige Steuerung der Arbeitsfunktionen
Pumpenregelung	Nullhubregelung, Bedarfsstromsteuerung - die Pumpen fördern nur so viel Öl, wie auch tatsächlich verbraucht wird, Druckabscheidung

Fördermengen max.	280 l/min
Betriebsdruck max.	330 bar

Separater Hydraulikkreis für Drehwerk

Pumpentyp	Zahnradpumpe
Fördermengen max.	35 l/min
Betriebsdruck max.	240 bar
Filtration	Hochleistungsfiltration mit Langzeitwechselintervall SENNEBOGEN HydroClean Feinfiltersystem mit Wasserabscheidung, optional
Kühlung	Sehr großdimensionierte Kühlereinheit

Hydrauliktank	440 l
Steuerung	Proportionale, feinfühlig hydraulische Ansteuerung der Bewegungen, 2 Servo Joysticks für die Arbeitsfunktionen, Zusatzfunktionen über Schalter und Fußpedale

Alle Hydraulikkreise sind mit Sicherheitsventilen abgesichert
Hohe Energie-Effizienz durch großdimensionierte Hydraulikventile und Leitungen
Hydraulikspeicher für Notablass der Ausrüstung bei Motorstillstand
Zentrale Messanschlüsse für Hydrauliktest
Rohrbruchsicherheitsventile im Wippzylinder
Rohrbruchsicherheitsventile im Teleskopzylinder

Drehwerk

Kompaktplanetengetriebe mit Schrägachsen-Hydraulikmotor, integrierten Bremsventilen	
Feststellbremse	Lamellenbremse, über Federn wirkend
Drehkranz	Starker Kugeldrehkranz, abgedichtet
Drehgeschwindigkeit	0-2 min ⁻¹ , stufenlos

Oberwagen

Bauart	Verwindungssteife Kastenbauweise, präzisionsbearbeitet, Stahlbüchsen für Auslegerlagerung, Klare, sehr servicefreundliche Konzeption, in Längsrichtung eingebauter Motor
--------	--

Kühlsystem

Kompakte 3-Kreis-Kühlereinheit mit großer Kühlleistung

Arbeitsausrüstung

Konstruktion	Jahrzehntelange Erfahrung und modernste Computersimulation garantieren ein Höchstmaß an Stabilität und Lebensdauer
Teleskopausleger	4-teilig mit Rollenkopf, hydr. teleskopierbar 23,4 m oder 30 m
Spitzenausleger	6,5 m bzw. 13 m Klappspitze, sehr schnell und ohne Hilfsgerät aufrüstbar, bei Nichtgebrauch wird dieser seitlich am Grundausleger verriegelt
Hubwinde	Antrieb über Schrägachsen Hydraulikmotor mit Kompaktplanetengetriebe, Zugkraft (1. Lage) 40 kN, Seilgeschwindigkeit 0-95 m/min. Seildurchmesser 14 mm, 2. Hubwinde optional
Sicherheitsbremse Kransicherheit	Lamellenbremse über Federn wirkend Neuste Generation der Lastmomentüberwachung, übersichtliches Tableau mit Anzeige aller wichtigen Daten, Hubendschalter, Seilablaufsicherung, Überdruckventile- und Rohrbruchsicherungen
Zylinder	Hydraulikzylinder mit hochwertigen Dichtungs- und Führungselementen

Unterwagen

Konstruktion	Starker Mobilunterwagen mit integrierter 4-Punkt-Abstützung, Lenkachse als hydraulisch feststellbare Pendelachse. Pendelachszylinder mit Rohrbruchsicherheitsventilen
Fahrtrieb	Allradantrieb über Verstellhydraulikmotor mit direkt angebautem, automatisch wirkendem Bremsventil und 2-Stufen-Lastschaltgetriebe. Starke 40t-Planetenachsen mit integrierten Lenkzylindern, Lamellenbremse als Betriebsbremse im 2-Kreis-System.
Lenkung	Allradlenkung
Parkbremse	Lamellenbremse über Federn wirkend
Bereifung	12.00-20, 8-fach 4-fach, 14.00R24 (Option)
Fahrgeschwindigkeit	0-6 km/h Gelände, 0-20 km/h Straße, 0-30 km/h optional für Export

Einsatzgewicht

643 M mit Teleausleger 30,0 m, Spitzenausleger 13 m, 20 t Haken, 2 Winden ca. 26.300 kg

643 M mit Teleausleger 23,4 m, 20 t Haken, 1 Winde ca. 24.000 kg

Das Einsatzgewicht variiert je nach Ausführung und Ausstattung. Technische Änderungen vorbehalten!

Specifications

Diesel engine

Output **128 kW/174 HP at 2000 rpm**
 Model **Deutz TCD 2012 L06 2V -TIER III**
 Direct injection, turbo charged, intercooler, reduced emission

Cooling Water cooled
 Air filter Dry air filter with precleaner, automatic dust discharge, main and safety element, pollution indicator

Fuel tank **300 l**
 Electric system 24 Volt
 Batteries 2 x 110 Ah, main switch

Hydraulic system

Load sensing/LUDV system for working functions and drive function

Hydraulic pump Variable displacement piston pump, swashplate type, load sensing regulation for parallel, independent operation of the working functions

Pump regulation Zero-flow regulation, flow on demand control - the pumps only supplying the required oil, pressure cut off

Oil flow max. **280 l/min**
 Pressure max. **330 bar**

Separate hydraulic circuit for swing operation

Pump type Gear pump
 Oil flow max. **35 l/min**
 Pressure max. **240 bar**
 Filtration High-efficiency filtration with long-time change interval, SENNEBOGEN HydroClean micro filtration with water separation, optional

Cooling Large-sized cooling unit

Hydraulic tank **440 l**

Steering Proportional, hydraulically and precise control of the hydraulic functions, 2 servo joysticks for operating movements, additional functions through switches and foot pedals

Safety valves for all hydraulic circuits
 High efficiency through well designed hydraulic valves and lines.
 Pressure accumulator for lowering of attachments when engine turned off
 Central pressure test ports
 Safety check valves for boom cylinders
 Safety check valves for telescopic boom cylinders

Slew drive

Compact planetary reduction gear with hydraulic piston motor, integrated brake valves
 Parking brake Multi-disc brake, spring-loaded
 Slew bearing Strong ball bearing, sealed
 Slew speed 0-2 rpm, stepless

Upper carriage

Design Torsion resistant box type design precision machined, steel bushes for the boom pivot.
 Clear, very servicefriendly design
 longitudinal installation of the engine

Cooling system

Compact 3-circuit cooling system, large sized

Working equipment

Design Decades of experience and state-of-the-art computer simulation guarantee highest stability and durability

Telescopic boom 4-section telescopic boom, full power hydraulically extendable, 23,4 m or 30 m

Folding jib 6.5 m or 13 m length, fast and easy erection, while not using it can be folded at the side of the mainboom

Hoist winch Axial piston hydraulic motor, planetary gear, linepull (1st layer) 40 kN, line speed 0-95 m/min, rope dia. 14 mm, 2. hoist winch optional

Safety brake Spring-applied multi disc brake

Crane safety State-of-the-art safe load indicator with colour graphic display, hoist limit switch, rope limit switch, pressure relief and safety check valves

Cylinders Hydraulic cylinders with high-grade seal and guide system

Undercarriage

Design Strong, rubber tired undercarriage with integrated 4-point outriggers, steering axle as oscillating axle lockable. Oscillating axle cylinders with safety check valves

Drive system All-wheel drive via variable displacement piston motor with directly mounted automatic brake valve and 2-stage power shift gear. Strong 40 t axles with integrated steering cylinder. Wet multi-disc brakes in 2-circuit system.

Steering All-wheel steering

Parking brake Multi disc brake, spring loaded

Tires 12.00-20, 8 tires
 4 tires 14.00R24 (optional)

Travel speeds 0-6 km/h off road, 0-20 km/h on road,
 0-30 km/h optional for export

Operating weight

643 M with telescopic boom 30.0 m, jib 13 m and hook block 20 t, 2 Winches **approx. 26,300 kg**

643 M with telescopic 23.4 m boom and 20 t hook block, 1 Winch **approx. 24,000 kg**

Operating weight may vary with depending on equipment and attachments. Subject to technical modification!

Ausleger / Boom



9 - 30 m

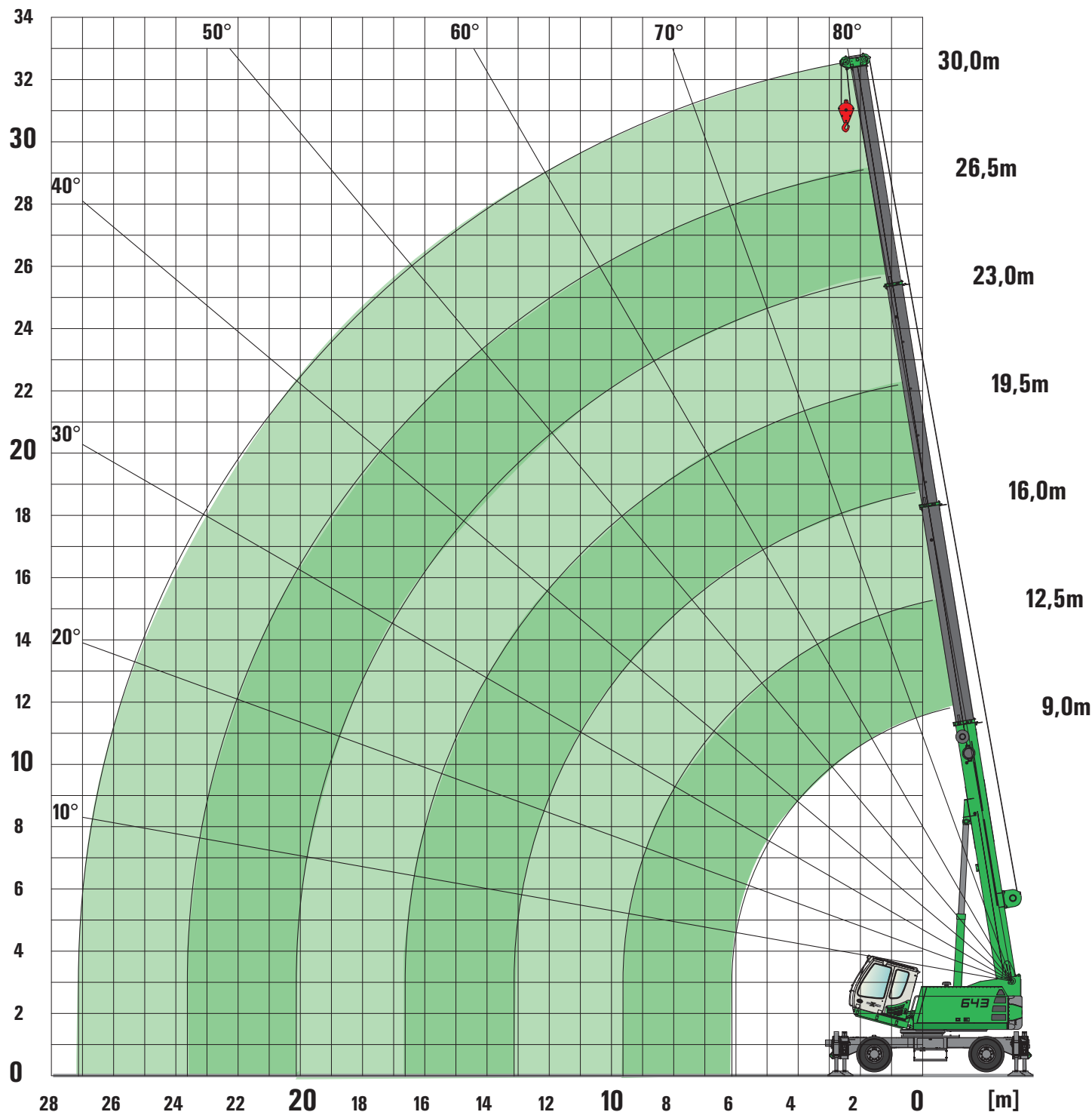

Anmerkung:

1. Die angegebenen Traglastwerte gelten für ebenen und festen Stand der Maschine
2. Die Traglastwerte sind in Tonnen angegeben und gelten für 360° Schwenkwinkel
3. Die Traglastwerte berücksichtigen die Normen DIN 15019.2, ISO 4305 sowie die Kippwinkelmethode (5°)
4. Das Gewicht der Lastaufnahmemittel (Haken, Gehänge) ist von den Traglasten abzuziehen
5. Lastwerte müssen begrenzt oder vermindert werden, um ungünstige Bedingungen zu berücksichtigen, wie weichen oder unebenen Boden, schräge

6. Zulässiger Seilzug je Strang bei Kranbetrieb ist bei 14 mm Seildurchmesser 3.500 kg
7. Traglasten mit * gekennzeichnet, gelten nur mit Sonderausrüstung
8. Die angegebenen Traglastwerte dienen nur zur Orientierung. Die jeweils gültigen Traglastwerte entnehmen Sie bitte den Tabellen in der Betriebsanleitung

Ausleger / Boom

DIN
ISO



9 - 30 m

Ausladung / Radius [m]	Auslegerlänge / Boom length [m]																					
	9,0			12,5			16,0			19,5			23,0			26,5			30,0			
	100%	50%	frei/free	100%	50%	frei/free	100%	50%	frei/free	100%	50%	frei/free	100%	50%	frei/free	100%	50%	frei/free	100%	50%	frei/free	
2,0	40,0*	35,0*	21,6*																			
3,0	30,1	27,1	12,0	20,0	20,0	12,0	15,0	15,0	12,0	14,0	14,0	12,5	11,0	11,0	11,0	8,9	8,9	8,9	5,0	5,0	5,0	5,0
4,0	24,8	20,4	7,3	20,0	20,0	7,1	15,0	15,0	7,1	14,0	14,0	7,6	11,0	11,0	7,8	8,9	8,9	8,1	5,0	5,0	5,0	5,0
5,0	18,8	12,8	4,9	18,5	12,6	4,8	15,0	12,5	4,7	13,3	13,1	5,1	11,0	11,0	5,4	8,6	8,6	5,6	5,0	5,0	5,0	5,0
6,0	13,4	9,0	3,4	13,2	8,9	3,3	13,1	8,8	3,2	12,0	9,3	3,6	10,3	9,6	3,8	8,3	8,3	4,0	5,0	5,0	4,0	4,0
7,0	12,7/6,2m	8,6/6,2m	3,1/6,2m	9,9	6,6	2,1	9,9	6,6	2,1	10,4	7,0	2,5	9,5	7,3	2,8	7,8	7,5	3,0	5,0	5,0	2,9	2,9
8,0				7,8	5,1	1,4	7,8	5,0	1,4	8,2	5,4	1,7	8,6	5,7	2,0	7,4	5,9	2,2	5,0	5,0	2,2	2,2
9,0				6,2	3,9	1,0	6,2	3,9	1,0	6,6	4,3	1,3	7,0	4,6	1,4	6,9	4,8	1,6	5,0	5,0	1,6	1,6
10,0				5,5/9,6m	3,4/9,6m	0,7/9,6m	5,1	3,1	0,6	5,5	3,4	0,8	5,8	3,7	1,1	6,0	3,9	1,3	5,0	4,1	1,2	1,2
11,0							4,2	2,5		4,5	2,8	0,5	4,9	3,0	0,7	5,1	3,2	0,9	5,0	3,4	0,9	0,9
12,0							3,4	2,0		3,8	2,2		4,1	2,5	0,5	4,3	2,7	0,6	4,5	2,9	0,6	0,6
13,0							2,8	1,5		3,2	1,8		3,5	2,1		3,7	2,3	0,4	3,9	2,4	0,4	0,4
14,0										2,7	1,5		3,0	1,7		3,2	1,9		3,4	2,0		
15,0										2,3	1,1		2,5	1,4		2,8	1,6		2,9	1,7		
16,0										1,9	0,9		2,2	1,1		2,4	1,3		2,5	1,4		
17,0										1,7/16,6m	0,7/16,6m		1,8	0,9		2,1	1,1		2,2	1,2		
18,0													1,6	0,7		1,8	0,9		1,9	1,0		
19,0													1,3	0,5		1,5	0,7		1,7	0,8		
20,0													1,1			1,3	0,5		1,4	0,7		
21,0													1,1/20,1m			1,1			1,2	0,5		
22,0																0,9			1,1			
23,0																0,7			0,9			
24,0																0,7/23,6m			0,7			
25,0																			0,6			
26,0	100% Tab-Nr.: 643M-30.0/75/2642/1.4/08.06																		0,5			
27,0	50% Tab-Nr.: 643M-30.0/75/2000/1.4/08.06																					
28,0	frei Tab-Nr.: 643M-30.0/75/1000/1.4/08.06																					
Strangzahl / Parts reeving	9	8	4	6	6	4	5	5	4	4	4	4	4	4	4	3	3	3	2	2	2	2
I	0%			50%			100%			100%			100%			100%			100%			
II	0%			0%			0%			25%			50%			75%			100%			
III	0%			0%			0%			25%			50%			75%			100%			

DIN
ISO



Ausladung / Radius [m]	Auslegerlänge / Boom length [m]																					
	9,0			12,5			16,0			19,5			23,0			26,5			30,0			
	100%	50%	frei/free	100%	50%	frei/free	100%	50%	frei/free	100%	50%	frei/free	100%	50%	frei/free	100%	50%	frei/free	100%	50%	frei/free	
2,0																						
3,0	6,0	6,0	6,0	6,0	6,0	6,0	6,0	6,0	6,0	6,0	6,0	6,0	6,0	6,0	6,0	6,0	6,0	6,0	5,0/3,5m	5,0/3,5m	5,0/3,5m	
4,0	6,0	6,0	6,0	6,0	6,0	6,0	6,0	6,0	6,0	6,0	6,0	6,0	6,0	6,0	6,0	6,0	6,0	6,0	5,0	5,0	5,0	
5,0	6,0	6,0	4,8	6,0	6,0	4,7	6,0	6,0	4,6	6,0	6,0	5,0	6,0	6,0	5,3	6,0	6,0	5,5	5,0	5,0	4,9	
6,0	6,0	6,0	3,3	6,0	6,0	3,2	6,0	6,0	3,1	6,0	6,0	3,5	6,0	6,0	3,7	6,0	6,0	3,9	5,0	5,0	4,0	
7,0	6,0/6,7m	6,0/6,7m	2,2/6,7m	6,0	6,0	2,0	6,0	6,0	2,0	6,0	6,0	2,4	6,0	6,0	2,7	6,0	6,0	2,9	5,0	5,0	2,9	
8,0				6,0	5,0	1,3	6,0	4,9	1,3	6,0	5,3	1,6	6,0	5,6	1,9	6,0	5,8	2,1	5,0	5,0	2,2	
9,0				6,0	3,8	0,9	6,0	3,8	0,9	6,0	4,2	1,2	6,0	4,5	1,3	6,0	4,7	1,5	5,0	4,9	1,6	
10,0				5,1	2,8		5,0	3,0	0,5	5,4	3,3	0,7	5,7	3,6	1,0	5,9	3,8	1,2	5,0	4,0	1,2	
11,0				5,0/10,2m	2,6/10,2m		4,1	2,4		4,4	2,7		4,8	2,9	0,6	5,0	3,1	0,8	4,9	3,3	0,9	
12,0							3,3	1,9		3,7	2,1		4,0	2,4		4,2	2,6	0,5	4,4	2,8	0,6	
13,0							2,7	1,4		3,1	1,7		3,4	2,0		3,6	2,2		3,8	2,3		
14,0							2,3/13,7m	1,0/13,7m		2,6	1,4		2,9	1,6		3,1	1,8		3,3	1,9		
15,0										2,2	1,0		2,4	1,3		2,7	1,5		2,8	1,6		
16,0										1,8	0,8		2,1	1,0		2,3	1,2		2,4	1,3		
17,0										1,6	0,6		1,7	0,8		2,0	1,0		2,1	1,1		
18,0										1,5/17,2m	0,5/17,2m		1,5	0,6		1,7	0,8		1,8	0,9		
19,0													1,2			1,4	0,6		1,6	0,7		
20,0													1,0			1,2			1,3	0,6		
21,0													1,0/20,7m			1,0			1,1			
22,0																0,8			1,0			
23,0																0,7			0,8			
24,0																0,5			0,6			
25,0																0,5/24,2			0,5			
26,0	100% Tab-Nr.: 643M-30.0/75/2642/1.4/08.06 S																					
27,0	50% Tab-Nr.: 643M-30.0/75/2000/1.4/08.06 S																					
28,0	frei Tab-Nr.: 643M-30.0/75/1000/1.4/08.06 S																					
Strangzahl / Parts reeving	2	2	2	2	2	2	2	2	2	2	2	2	2	2	2	2	2	2	2	2	2	
I	0%			50%			100%			100%			100%			100%			100%			
II	0%			0%			0%			25%			50%			75%			100%			
III	0%			0%			0%			25%			50%			75%			100%			

Bei angebaumtem Spitzenausleger am Grundkörper müssen die Traglastwerte reduziert werden:
When the jib is mounted at the basic mainboom the rated loads have to be reduced:

Länge Hauptausleger Main boom length	[m]	9,0	12,5	16,0	19,5	23,0	26,5	30,0
Traglastreduzierung Reduction of load	[kg]	570	420	330	280	240	210	180

Spitzenausleger/ Folding jib





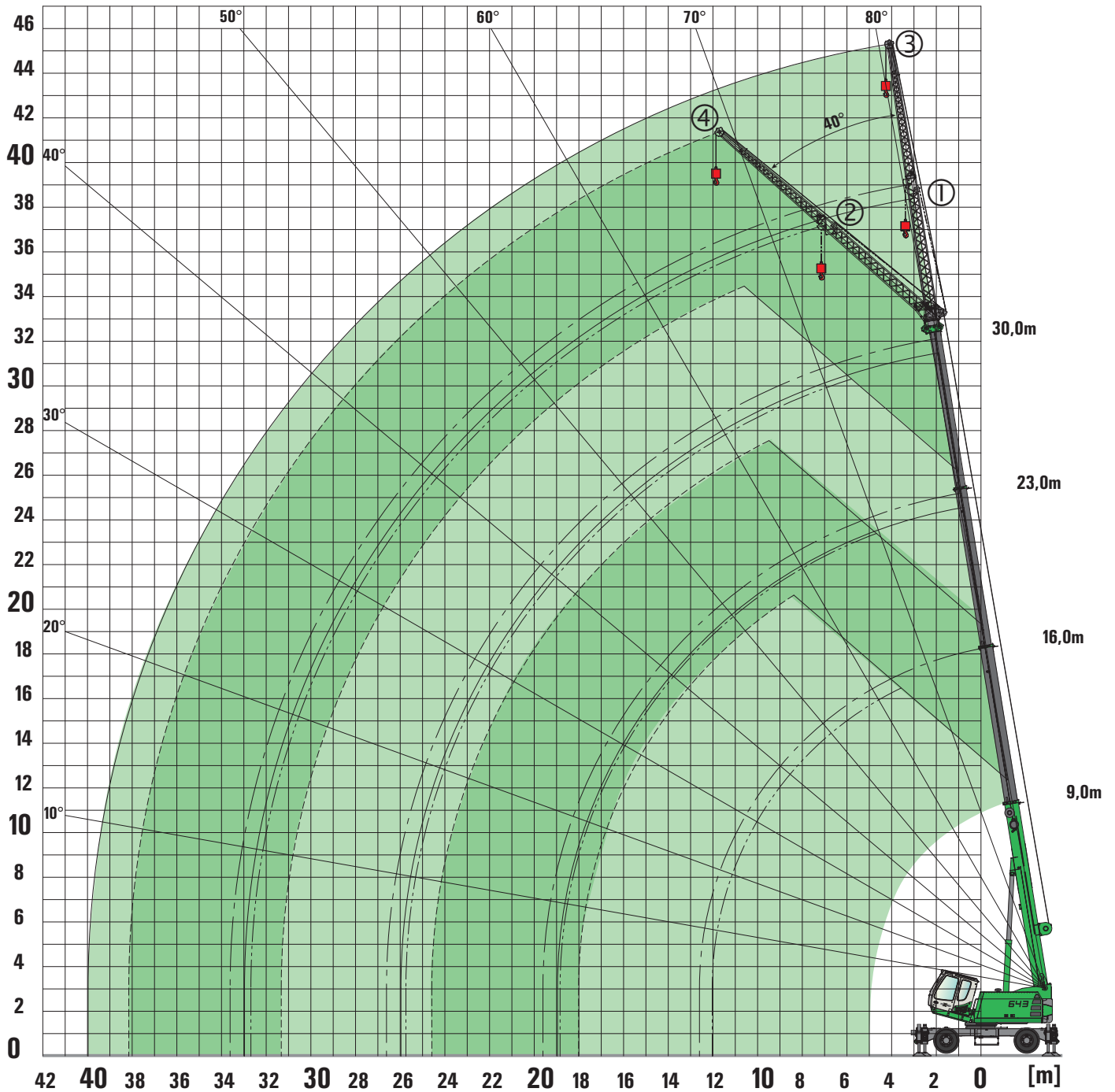

- ① 6,5 m / 0°
- ② 6,5 m / 40°
- ③ 13 m / 0°
- ④ 13 m / 40°





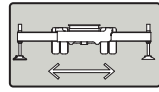

Notes:

1. The rated loads shown are based on the machine on firm level ground and without travelling
2. The rated loads shown are in metric tons valid for 360 degrees swing
3. Liftcrane capacities are calculated to comply with DIN 15019.2, ISO 4305 and 5° tipping angle
4. The rated loads shown include the weight of all lifting attachments, such as hook and bucket etc.
5. Users must derate or limit the lifted loads to allow for adverse conditions such as soft or uneven ground, out-of-level conditions, wind, side loads, pendulum action, jerking or sudden stopping of loads, inexperience of personnel and travelling with a load
6. Max. single line pull for crane operation with rope diameter 14 mm - 3,500 kg
7. Loads marked with * are only valid with special equipment.
8. Lifting capacities are for reference only. For actual lifting capacities please refer to load chart in operator's manual.

Spitzenausleger / Folding jib



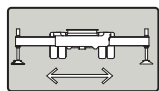

30 m

6,5 m

Ausladung / Radius	Auslegerlänge / Boom length [m]							
	9,0		16,0		23,0		30,0	
	0°	40°	0°	40°	0°	40°	0°	40°
2,0								
3,0	6,0		6,0					
4,0	6,0		6,0					
5,0	5,5	3,5	6,0		6,0			
6,0	4,9	3,3	6,0	3,6	6,0			
7,0	4,4	3,1	5,9	3,4	6,0		3,5	
8,0	4,0	2,9	5,4	3,3	5,9	3,4	3,5	
9,0	3,7	2,8	5,0	3,2	5,5	3,3	3,5	
10,0	3,4	2,7	4,6	3,1	4,7	3,2	3,5	3,2
11,0	3,1		4,3	3,0	4,0	3,2	3,5	3,0
12,0	2,8		3,7	2,8	3,5	3,1	3,2	2,9
13,0			3,2	2,8	3,0	3,0	2,8	2,8
14,0			2,8	2,8	2,6	2,9	2,5	2,7
15,0			2,4		2,3	2,8	2,1	2,5
16,0			2,1		2,0	2,4	1,9	2,4
18,0			1,5		1,5	1,8	1,4	1,8
20,0					1,1	1,3	1,0	1,3
22,0					0,7		0,7	1,0
24,0								0,6
26,0								
28,0								
30,0								
32,0								
34,0								
36,0								
38,0	Tab-Nr.: 643M-30.0/75/2642/1.4/08.06 SA6.5							
Strangzahl / Parts reeving	2	1	2	2	2	1	1	1
I	0%		100%		100%		100%	
II	0%		0%		50%		100%	
III	0%		0%		50%		100%	





30 m

13 m

Ausladung / Radius	Auslegerlänge / Boom length [m]							
	9,0		16,0		23,0		30,0	
	0°	40°	0°	40°	0°	40°	0°	40°
2,0								
3,0	6,0		6,0					
4,0	6,0		6,0					
5,0	5,5	3,5	6,0		6,0			
6,0	4,9	3,3	6,0	3,6	6,0			
7,0	4,4	3,1	5,9	3,4	6,0		3,5	
8,0	4,0	2,9	5,4	3,3	5,9	3,4	3,5	
9,0	3,7	2,8	5,0	3,2	5,5	3,3	3,5	
10,0	3,4	2,7	4,6	3,1	4,7	3,2	3,5	3,2
11,0	3,1		4,3	3,0	4,0	3,2	3,5	3,0
12,0	2,8		3,7	2,8	3,5	3,1	3,2	2,9
13,0			3,2	2,8	3,0	3,0	2,8	2,8
14,0			2,8	2,8	2,6	2,9	2,5	2,7
15,0			2,4		2,3	2,8	2,1	2,5
16,0			2,1		2,0	2,4	1,9	2,4
18,0			1,5		1,5	1,8	1,4	1,8
20,0					1,1	1,3	1,0	1,3
22,0					0,7		0,7	1,0
24,0								0,6
26,0								
28,0								
30,0								
32,0								
34,0								
36,0								
38,0	Tab-Nr.: 643M-30.0/75/2642/1.4/08.06 SA6.5							
Strangzahl / Parts reeving	2	1	2	2	2	1	1	1
I	0%		100%		100%		100%	
II	0%		0%		50%		100%	
III	0%		0%		50%		100%	

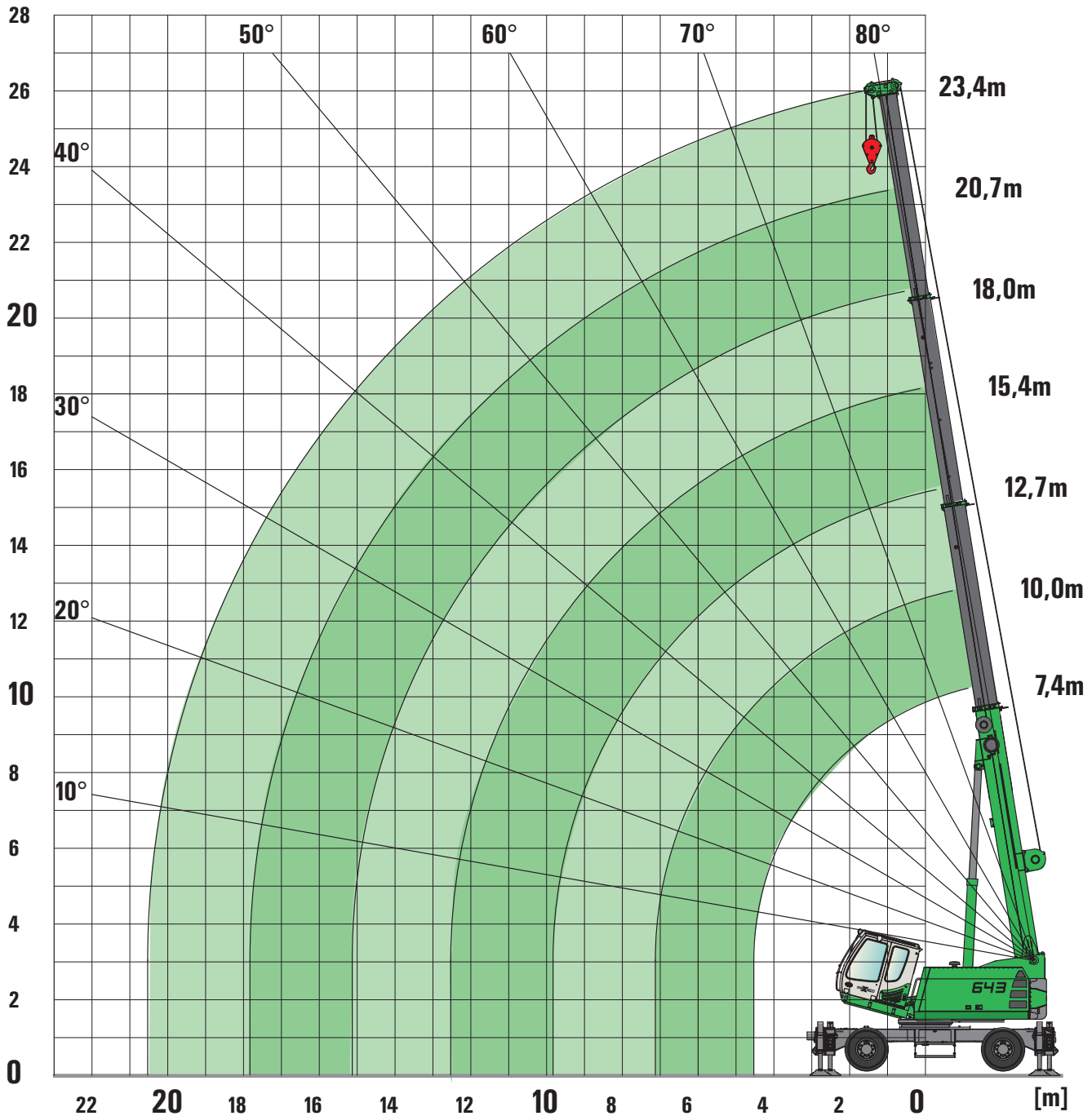
Ausleger / Boom



7,4 - 23,4 m



Anmerkung:

1. Die angegebenen Traglastwerte gelten für ebenen und festen Stand der Maschine
2. Die Traglastwerte sind in Tonnen angegeben und gelten für 360° Schwenkwinkel
3. Die Traglastwerte berücksichtigen die Normen DIN 15019.2, ISO 4305 sowie die Kippwinkelmethode (5°)
4. Das Gewicht der Lastaufnahmemittel (Haken, Gehänge) ist von den Traglasten abzuziehen
5. Lastwerte müssen begrenzt oder vermindert werden, um ungünstige Bedingungen zu berücksichtigen, wie weichen oder unebenen Boden, schräge

- Gefälle, Wind, Seitenlasten, schwingende Lasten, Rucken oder plötzliches Stoppen der Ladungen, Unerfahrenheit des Personals, Fahren mit Last
6. Zulässiger Seilzug je Strang bei Kranbetrieb ist bei 14 mm Seildurchmesser 3.500 kg
7. Traglasten mit * gekennzeichnet, gelten nur mit Sonderausrüstung
8. Die angegebenen Traglastwerte dienen nur zur Orientierung. Die jeweils gültigen Traglastwerte entnehmen Sie bitte den Tabellen in der Betriebsanleitung

Ausleger / Boom

DIN
ISO



7,4 - 23,4 m

Ausladung / Radius [m]	Auslegerlänge / Boom length [m]																					
	7,4			10,0			12,7			15,4			18,0			20,7			23,4			
	100%	50%	frei/free	100%	50%	frei/free	100%	50%	frei/free	100%	50%	frei/free	100%	50%	frei/free	100%	50%	frei/free	100%	50%	frei/free	
2,0	40,0*	40,0*	40,0*																			
3,0	30,8	27,8	12,3	22,0	22,0	11,9	18,0	18,0	11,7	15,0	15,0	12,2	12,5	12,5	12,5	10,0	10,0	10,0	9,0	9,0	9,0	
4,0	25,4	18,9	7,6	22,0	18,5	7,3	18,0	18,0	7,2	15,0	15,0	7,6	12,5	12,5	7,8	10,0	10,0	8,0	9,0	9,0	8,2	
5,0	13,6/4,5m	13,6/4,5m	6,2/4,5m	18,3	12,4	5,1	18,0	12,2	4,9	14,6	12,2	5,2	12,5	12,5	5,5	10,0	10,0	5,6	9,0	9,0	5,8	
6,0				13,2	8,9	3,6	13,0	8,7	3,5	13,0	9,1	3,8	11,3	9,3	4,1	10,0	9,5	4,2	9,0	9,0	4,3	
7,0				10,0	6,7	2,7	10,0	6,6	2,6	10,4	6,9	2,9	10,1	7,1	3,1	9,2	7,3	3,2	8,1	7,4	3,3	
8,0				9,8/7,2m	6,5/7,2m	2,6/7,2m	7,9	5,2	1,9	8,3	5,5	2,2	8,5	5,7	2,4	8,2	5,8	2,5	7,4	6,0	2,6	
9,0							6,4	4,1	1,4	6,8	4,5	1,7	7,0	4,7	1,9	7,2	4,8	2,0	6,8	4,9	2,1	
10,0							5,5/9,8m	3,5/9,8m	1,1/9,8m	5,7	3,7	1,3	5,8	3,9	1,4	6,0	4,0	1,6	6,1	4,1	1,7	
11,0										4,8	3,0	0,9	4,9	3,2	1,1	5,1	3,4	1,3	5,2	3,5	1,4	
12,0										4,1	2,5	0,7	4,2	2,7	0,9	4,4	2,9	1,0	4,5	3,0	1,1	
13,0										3,8/12,5m	2,3/12,5m	0,6/12,5m	3,6	2,3	0,6	3,8	2,5	0,8	3,9	2,6	0,9	
14,0													3,2	2,0		3,3	2,1	0,6	3,4	2,2	0,7	
15,0													2,7	1,7		2,9	1,8		3,0	1,9	0,5	
16,0													2,7/15,2m	1,6/15,2m		2,6	1,6		2,6	1,7		
17,0															2,3	1,3		2,3	1,4			
18,0															2,1/17,8m	1,2/17,8m		2,1	1,2			
19,0																	1,8		1,8	1,1		
20,0																	1,6		1,6	0,9		
21,0																			1,5/20,5m	0,9/20,5m		
22,0																						
23,0																						
24,0																						
25,0																						
26,0	100% Tab-Nr.: 643M-23.4/75/2642/1.4/08.06																					
27,0	50% Tab-Nr.: 643M-23.4/75/2000/1.4/08.06																					
28,0	frei Tab-Nr.: 643M-23.4/75/1000/1.4/08.06																					
Strangzahl / Parts reving	9	8	4	7	7	4	6	6	4	5	5	4	4	4	4	3	3	3	3	3	3	
I	0%			50%			100%			100%			100%			100%			100%			
II	0%			0%			0%			25%			50%			75%			100%			
III	0%			0%			0%			25%			50%			75%			100%			

DIN
ISO



Ausladung / Radius [m]	Auslegerlänge / Boom length [m]																					
	7,4			10,0			12,7			15,4			18,0			20,7			23,4			
	100%	50%	frei/free	100%	50%	frei/free	100%	50%	frei/free	100%	50%	frei/free	100%	50%	frei/free	100%	50%	frei/free	100%	50%	frei/free	
2,0																						
3,0	6,0	6,0	6,0	6,0	6,0	6,0	6,0	6,0	6,0	6,0	6,0	6,0	6,0	6,0	6,0	6,0	6,0	6,0	6,0/3,5m	6,0/3,5m	6,0/3,5m	
4,0	6,0	6,0	6,0	6,0	6,0	6,0	6,0	6,0	6,0	6,0	6,0	6,0	6,0	6,0	6,0	6,0	6,0	6,0	6,0	6,0	6,0	
5,0	6,0	6,0	5,0	6,0	6,0	5,0	6,0	6,0	4,8	6,0	6,0	5,1	6,0	6,0	5,4	6,0	6,0	5,5	6,0	6,0	5,7	
6,0	6,0/5,1m	6,0/5,1m	4,9/5,1m	6,0	6,0	3,5	6,0	6,0	3,4	6,0	6,0	3,7	6,0	6,0	4,0	6,0	6,0	4,1	6,0	6,0	4,2	
7,0				6,0	6,0	2,6	6,0	6,0	2,5	6,0	6,0	2,8	6,0	6,0	3,0	6,0	6,0	3,1	6,0	6,0	3,2	
8,0				6,0/7,7m	4,8/7,7m	1,8/7,7m	6,0	5,1	1,8	6,0	5,4	2,1	6,0	5,6	2,3	6,0	5,7	2,4	6,0	5,9	2,5	
9,0							6,0	4,0	1,3	6,0	4,4	1,6	6,0	4,6	1,8	6,0	4,7	1,9	6,0	4,8	2,0	
10,0							5,4	3,2	1,0	5,6	3,6	1,2	5,7	3,8	1,3	5,9	3,9	1,5	6,0	4,0	1,6	
11,0							5,1/10,4m	2,7/10,4m	0,8/10,4m	4,7	2,9	0,8	4,8	3,1	1,0	5,0	3,3	1,2	5,1	3,4	1,3	
12,0										4,0	2,4	0,6	4,1	2,6	0,8	4,3	2,8	0,9	4,4	2,9	1,0	
13,0										3,4	2,0	0,5	3,5	2,2	0,5	3,7	2,4	0,7	3,8	2,5	0,8	
14,0										3,4/13,1m	1,9/13,1m	0,5/13,1m	3,1	1,9		3,2	2,0	0,5	3,3	2,1	0,6	
15,0													2,6	1,6		2,8	1,7		2,9	1,8		
16,0													2,2/15,7m	1,4/15,7m		2,5	1,5		2,5	1,6		
17,0															2,2	1,2		2,2	1,3			
18,0															1,9	1,0		2,0	1,1			
19,0															1,8/18,4m	0,9/18,4m		1,7	1,0			
20,0																	1,5		1,5	0,8		
21,0																			1,2	0,6		
22,0																			1,2/21,1m	0,6/21,1m		
23,0																						
24,0																						
25,0																						
26,0	100% Tab-Nr.: 643M-23.4/75/2642/1.4/08.06 S																					
27,0	50% Tab-Nr.: 643M-23.4/75/2000/1.4/08.06 S																					
28,0	frei Tab-Nr.: 643M-23.4/75/1000/1.4/08.06 S																					
Strangzahl / Parts reving	2	2	2	2	2	2	2	2	2	2	2	2	2	2	2	2	2	2	2	2	2	
I	0%			50%			100%			100%			100%			100%			100%			
II	0%			0%			0%			25%			50%			75%			100%			
III	0%			0%			0%			25%			50%			75%			100%			

Bei angebautem Spitzenausleger am Grundkörper müssen die Traglastwerte reduziert werden:
When the job is mounted at the basic mainboom the rated loads have to be reduced:

Länge Hauptausleger Main boom length	[m]	7,4	10,0	12,7	15,4	18,0	20,7	23,4
Traglastreduzierung Reduction of load	[kg]	570	420	330	280	240	210	180

Spitzenausleger / Folding jib



- ① 6,5 m / 0°
- ② 6,5 m / 40°
- ③ 13 m / 0°
- ④ 13 m / 40°

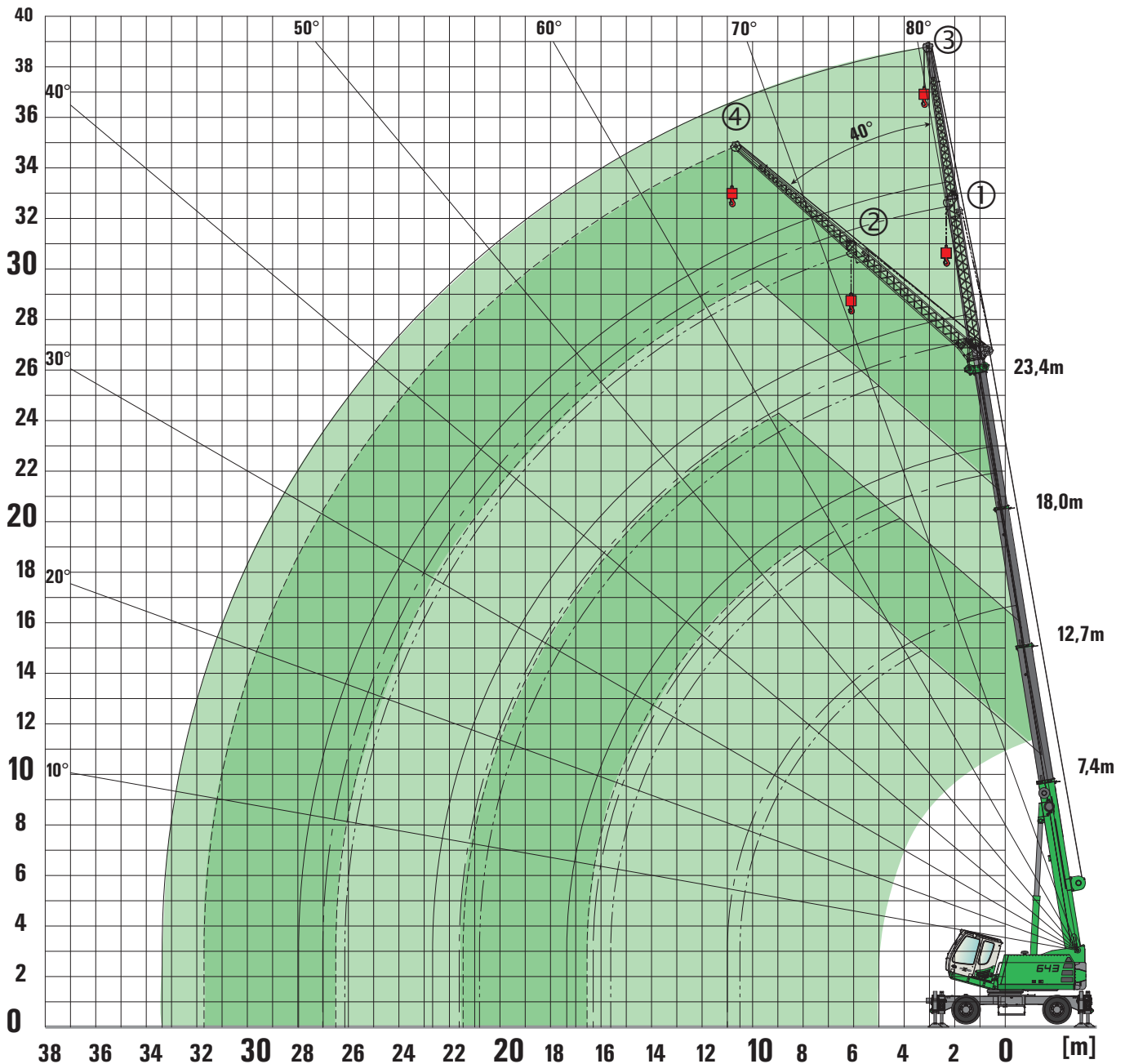

Notes:

1. The rated loads shown are based on the machine on firm level ground and without travelling
2. The rated loads shown are in metric tons valid for 360 degrees swing
3. Liftcrane capacities are calculated to comply with DIN 15019.2, ISO 4305 and 5° tipping angle
4. The rated loads shown include the weight of all lifting attachments, such as hook and bucket etc.
5. Users must derate or limit the lifted loads to allow for adverse conditions such as soft or uneven ground, out-of-level conditions, wind, side loads, pendulum action, jerking or sudden stopping of loads, inexperience of personnel and travelling with a load
6. Max. single line pull for crane operation with rope diameter 14 mm - 3,500 kg
7. Loads marked with * are only valid with special equipment.
8. Lifting capacities are for reference only. For actual lifting capacities please refer to load chart in operator's manual.

Spitzenausleger / Folding jib









23,4 m

6,5 m

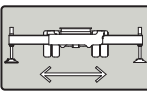
Ausladung / Radius	Auslegerlänge / Boom length [m]							
	7,4		12,7		18,0		23,4	
	0°	40°	0°	40°	0°	40°	0°	40°
2,0								
3,0	6,0		6,0		6,0			
4,0	5,6	3,6	6,0		6,0			
5,0	4,9	3,4	6,0	3,6	6,0		5,5	
6,0	4,4	3,2	5,8	3,5	6,0		5,5	
7,0	4,0	3,0	5,2	3,3	6,0	3,4	5,5	
8,0	3,6	2,8	4,8	3,2	5,6	3,3	5,1	3,4
9,0	3,2	2,7	4,4	3,0	5,2	3,2	4,8	3,3
10,0	2,9		4,1	2,9	4,9	3,1	4,4	3,2
11,0			3,8	2,7	4,5	3,0	4,1	3,1
12,0			3,5	2,7	4,0	2,9	3,8	3,0
13,0			3,3	2,7	3,6	2,8	3,4	2,8
14,0			3,1		3,1	2,8	3,0	2,7
15,0			2,9		2,8	2,8	2,6	2,6
16,0			2,6		2,5	2,7	2,3	2,5
18,0					2,0		1,9	2,1
20,0					1,6		1,5	1,7
22,0							1,1	
24,0							0,9	
26,0							0,7	
28,0								
30,0								
32,0								
34,0								
36,0								
38,0	Tab-Nr.: 643M-23.4/75/2642/1.4/08.06 SA6.5							
Strangzahl / Parts reeving	2	2	2	2	2	1	2	1
I	0%		100%		100%		100%	
II	0%		0%		50%		100%	
III	0%		0%		50%		100%	





23,4 m

13 m

Ausladung / Radius	Auslegerlänge / Boom length [m]							
	7,4		12,7		18,0		23,4	
	0°	40°	0°	40°	0°	40°	0°	40°
2,0								
3,0	3,0							
4,0	3,0		3,0					
5,0	3,0		3,0					
6,0	3,0		3,0		3,0			
7,0	2,7		3,0		3,0		3,0	
8,0	2,4		2,9		3,0		3,0	
9,0	2,2		2,7		3,0		3,0	
10,0	2,0	1,6	2,5		2,8		2,9	
11,0	1,8	1,5	2,3	1,6	2,6		2,7	
12,0	1,7	1,4	2,1	1,5	2,4	1,6	2,6	
13,0	1,7	1,3	2,0	1,5	2,3	1,5	2,4	
14,0	1,6	1,2	1,9	1,4	2,2	1,5	2,3	1,5
15,0	1,5	1,2	1,8	1,4	2,1	1,4	2,2	1,5
16,0	1,3	1,2	1,7	1,3	2,0	1,4	2,1	1,4
18,0			1,5	1,3	1,8	1,3	2,0	1,4
20,0			1,4	1,3	1,7	1,3	1,8	1,3
22,0			1,3		1,5	1,3	1,4	1,3
24,0					1,3	1,3	1,2	1,3
26,0					1,1		1,0	1,2
28,0					0,9		0,8	1,0
30,0							0,6	
32,0								
34,0								
36,0								
38,0	Tab-Nr.: 643M-23.4/75/2642/1.4/08.06 SA13.0							
Strangzahl / Parts reeving	1	1	1	1	1	1	1	1
I	0%		100%		100%		100%	
II	0%		0%		50%		100%	
III	0%		0%		50%		100%	

Maße / dimensions



8 x 12.00.20



7,4 - 23,4 m

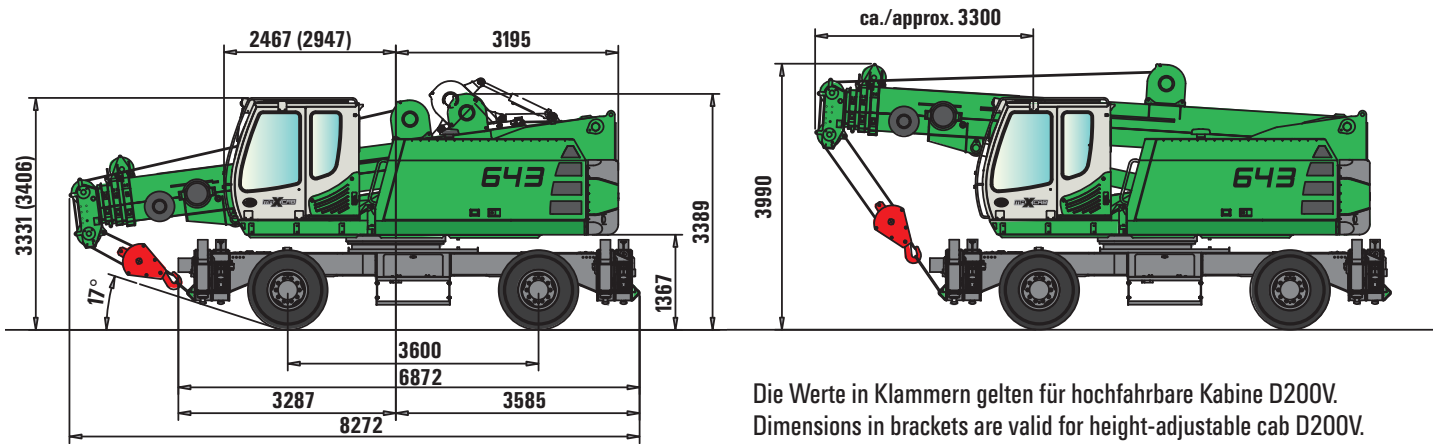

Die Werte in Klammern gelten für hochfahrbare Kabine D200V.
Dimensions in brackets are valid for height-adjustable cab D200V.



9 - 30 m

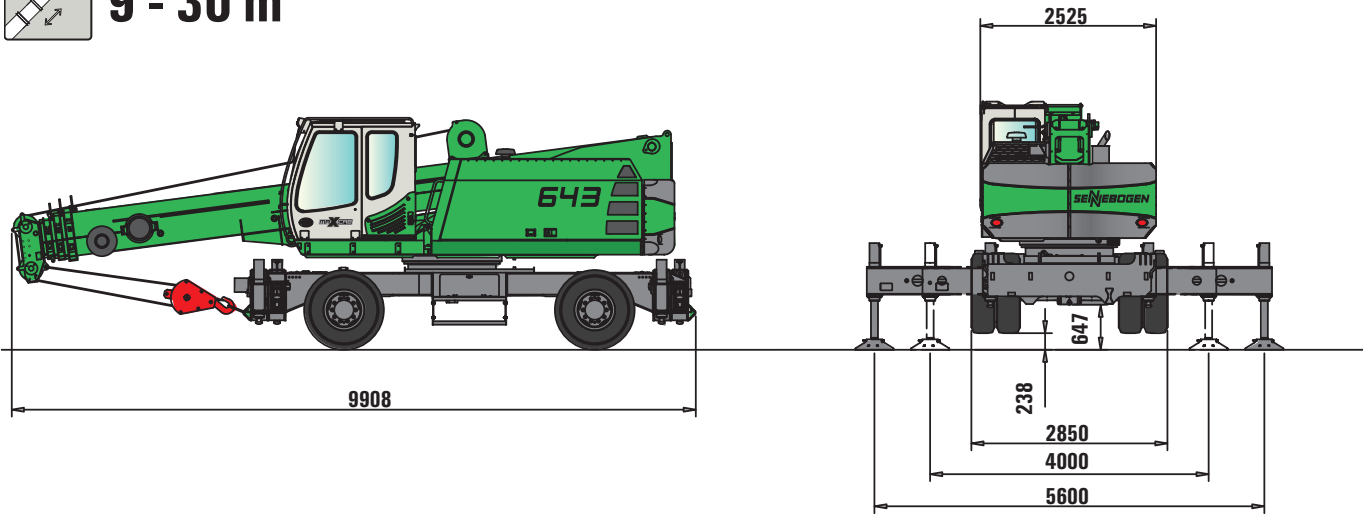

6 t

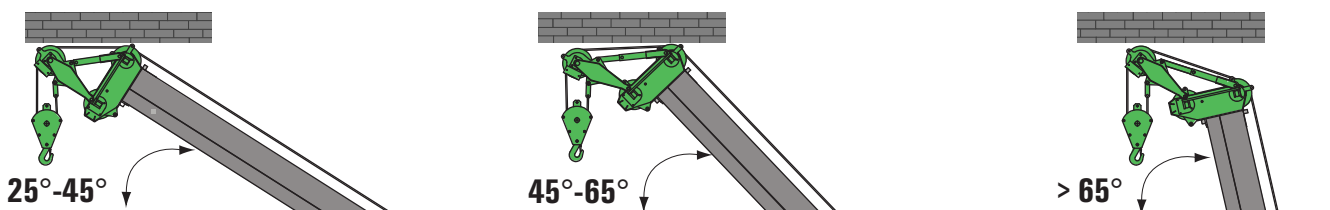

Maße / dimensions



4 x 14.00R24



7,4 - 23,4 m

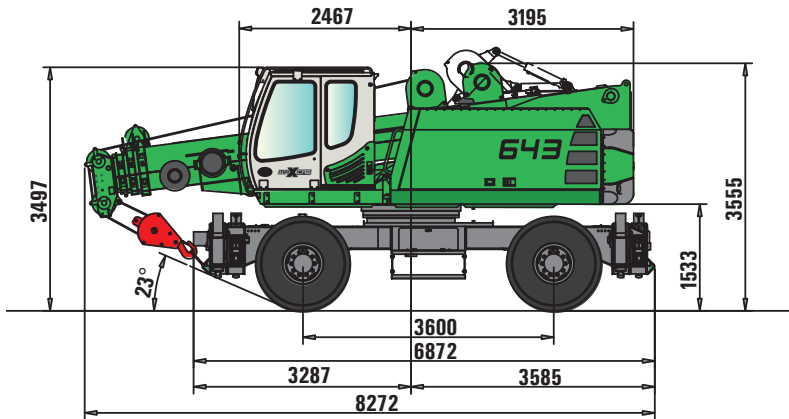

9 - 30 m

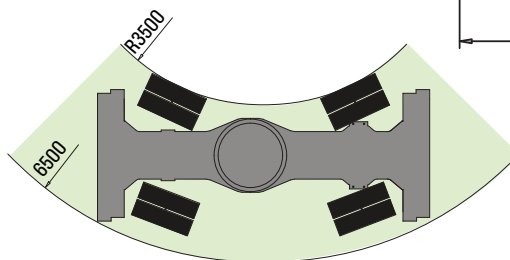
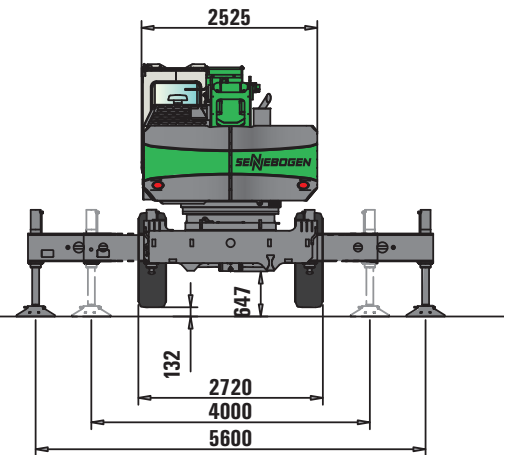
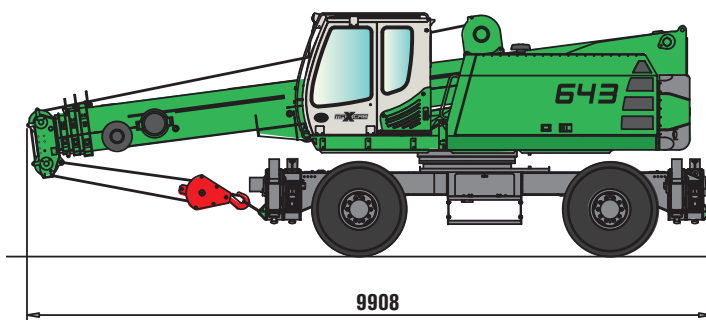

300 kg		32.000 kg	28.000 kg	24.500 kg	21.000 kg	17.500 kg	14.000 kg	10.500 kg	7.000 kg	3.500 kg
220 kg					20.000 kg	17.500 kg	14.000 kg	10.500 kg	7.000 kg	3.500 kg
40 kg										3.500 kg

643_M

Neue Großraum-Komfortkabine mit Schiebetür

New king-sized comfort cabin with sliding door

MAX CAB

Luftgefederter Komfortsitz

mehrfach verstellbar mit Bandscheibenstütze und Sitzheizung, einstellbare Armlehnen

Air suspended comfort seat

adjustable with lumbar support and seat heating, adjustable armrests



Beste Ergonomie

Sitz ergonomisch komplett individuell zu den Steuerhebeln und separat zu den Fußpedalen einstellbar

Best ergonomics

Ergonomic operator's seat, individually adjustable in height and angle for optimum working environment and operator's comfort



Schiebetür

erleichtert sicheres und bequemes Ein- und Aussteigen

Sliding door

Simplified and safe access to the operator's cab



Hydraulisch um 15° neigbare Kabine

mit getöntem Sicherheitsglas, hydraulisch gedämpft und schwingungsgedämpft gelagert

Hydraulically tiltable cab; 15°

with safety glass tinted, hydraulically damped, resiliently mounted

Trittrost mit Geländer

serienmäßig = Sicherheit beim Auf- und Abstieg

Step with railing

Standard - safety in entering and exiting



SENNEBOGEN Diagnostic-System

zur Überwachung aller wichtigen Maschinen- und Motorfunktionen

SENNEBOGEN Diagnostic system

for monitoring of all essential machine and engine functions



Heiz-Klimaautomatik

mit Temperatursteuerung, 8 einstellbare Lüfterdüsen sorgen für wohlige Klima, starke Defrosterfunktion, Frischluft/ Umluftsteuerung mit Partikelfilter

Automatic regulation

of heating and air condition according to temperature setting, 8 adjustable air vents provide excellent defrosting, air/circulation function, particle filter for outside and circulation air

SENNEBOGEN

SENNEBOGEN

Maschinenfabrik GmbH

Sennebogenstraße 10

94315 Straubing, Germany

Tel. +49 9421 540-144/146

Fax +49 9421 43 882

marketing@sennebogen.de