

DEUTZ-FAHR

Serie 60



SMART EVOLUTION.



The renowned qualities of DEUTZ-FAHR combine harvesters are solidly reaffirmed in the new 60 series 5 and 6 straw walker machines, the 6060, 6060 HTS, 6065 HTS, 6090, 6090 HTS and 6095 HTS. With their power, comfort and economy, complemented by new advanced technology, these new combines are the very embodiment of top quality.

The 60 series reflects over 100 years of experience and steadily evolving technology. Just as in 1909 when the Ködel & Böhm predecessor to today's machine represented a landmark and a technological benchmark in terms of performance and quality, so today, the 60 series leads the way for this class of machine, maintaining the qualities that have always stood out in the long history of our brand.

The features of the new 60 series are in keeping with the principles of DEUTZ-FAHR design:

- Maximum performance when harvesting all types of crops
- Outstanding operating economy
- Exceptional grain sample
- Unparalleled ease of maintenance





CUT INEFFICIENCY TO THE MINIMUM WITH THE SERIES 60.



Historically, DEUTZ-FAHR headers have always been renowned for:

- Precision control
- Fast cutting action
- Strength and reliability

A chassis frame using the most modern design and construction ensures optimum weight distribution and stability, irrespective of the cutting width. The construction method also guarantees long life and dependable performance on all types of terrain and harvesting conditions.

AUTOCONTROL

The acclaimed header control system used on DEUTZ-FAHR combine harvesters is able to ensure that any type of header can follow the ground contours closely, and that its position is adjusted to different harvesting conditions, whether by selection of the cutting height, or ground pressure, or lateral

float of the header; the operator can set and manage the appropriate work parameters directly from the cab, leaving the actual adjustments to the automatic control functions.

Schumacher cutting system

The tandem cutting system used on DEUTZ-FAHR harvesters produces a clean and precise cut, even on badly laid crops; with the planetary knife drive, a cutting frequency of 1,220 cuts per minute can be achieved, but more importantly, the cutting action movement is in line, hence less affected by wear, vibration and with a lower power demand.

Proportional reel speed control

All DEUTZ-FAHR headers are equipped with a reel turning at a speed proportional to the ground speed. Once the optimum feed density has been established, the feed rate will

be held steady by the machine itself, according to the current work rate; this guarantees a highly uniform crop flow toward the header knife, thereby reducing the demands on the attention of the operator still further.

Special equipment

Our alternative crop headers are designed with multi-capability firmly in mind.

Both the sunflower kit and the oil seed rape kit are easily fitted to the standard grain header; with these accessories, harvest-time can be extended, and the machine utilized even more profitably.

ADVANTAGES

- ▶ High performance headers with working widths of 4.2 m to 7.2 m
- ▶ Large diameter auger with spirally arranged feed fingers
- ▶ Planetary knife drive for a fast, clean cut
- ▶ Folding crop dividers and hydraulic multi coupling for simple and rapid fitment/ removal of the header
- ▶ Autocontrol system for automatic adjustment of cutting height and lateral tilt
- ▶ Variostar header
- ▶ Special attachments for oil seed rape and sunflower harvesting



Thanks to a planetary drive and a cutting frequency of 1,220 cuts/min, the knife cuts swiftly and cleanly through the crop, whatever the harvesting conditions.

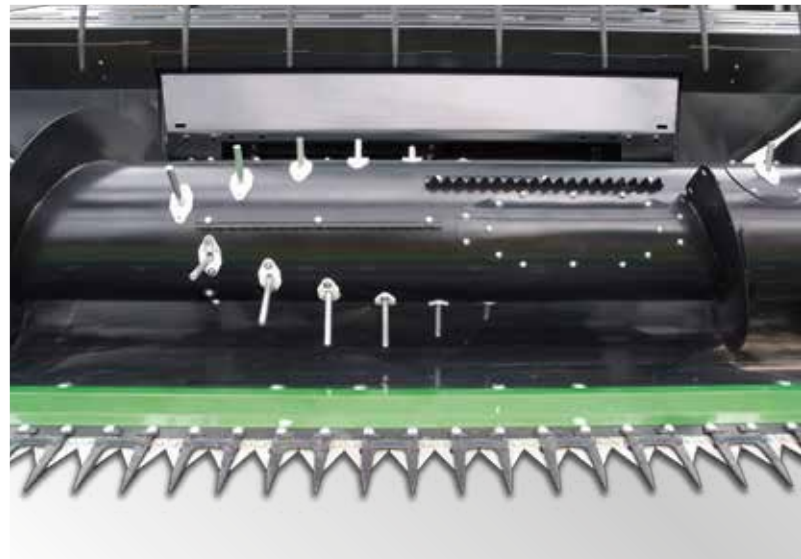

The intake auger with deep flights and the intake fingers ensure a continuous crop intake and throughput.



Skids ensure that the header follows the ground contours closely, compensating on the move for every ground undulation.



An electrically operated reversing unit is designed to eliminate any overloading of the feed system.



Alternately mounted knife sections (Schumacher) suffer less wear and ensure a clean cut every time.



Variostar headers provide optimum adaptation to all crops.



The oil seed rape attachment allows easy conversion of the standard cereal header, increasing its all-round versatility.



The sunflower attachment ensures that only seed heads are harvested, for maximum effectiveness of the threshing operation.

**WHEN THE RIDE GETS BUMPY, THE 60 SERIES
KEEPS GOING “STRAIGHT AS AN ARROW”,
DELIVERING MAXIMUM PERFORMANCE.**



ADVANTAGES

- ▶ Increased performance and comfort provided by a completely automatic level control system
- ▶ Pivoting portal axles allows up to 20% compensation for side slopes
- ▶ Optimum leveling and positioning of the header on all types of terrain
- ▶ Compensation for axial gradients up to 6% up-hill or down-hill
- ▶ Complete utilization of the grain tank
- ▶ Automatic cutting angle control
- ▶ Electrohydraulic cutting angle adjustment



AUTOCONTROL adjusts the lateral and vertical movement of the header with notable precision, so as to maintain a steady cutting height and ensure that laid crops can be harvested to optimum effect, with the cleanest possible cut.



Final drive units rated 25 t enable the machine to work in the most hostile conditions while guaranteeing optimum reliability, and more importantly, maximum operator safety.



Electrohydraulic adjustment of the cutting angle ensures the position of the cutting bar is optimised relative to the direction of travel.

On sloping terrain, the BALANCE system ensures the same quality and capacity of the threshing operation as on level ground. The inclination of the harvester is measured by potentiometers mounted to the wheels, providing an input signal processed by an electronic control unit that relays control impulses immediately to the hydraulic system. In practice, DEUTZ-FAHR combines equipped with the BALANCE system are able to stay permanently horizontal, compensating side slopes up to 20%, and up/down-hill slopes up to 6%. The threshing, straw walker and cleaning systems ensure that crops are processed efficiently and uniformly, with ultimate productivity guaran-

teed. On BALANCE versions, the generously sized grain tank can be filled to its full capacity of 8,500 litres even in the trickiest operating conditions. With uniform distribution of weight on the drive wheels, the combine is able to benefit from optimum power transfer in all situations. The BALANCE function is activated simply by pressing a button in the cab, and the position of the machine can be corrected manually should the need arise. With automatic cutting angle control - a Deutz-Fahr exclusive - the feed to the threshing drum remains steady in the face of changing ground contours, and a constantly adjusted cutting angle prevents unnecessary ground engagement by the knife.

IN ADDITION TO ULTIMATE PRODUCTION CAPACITY, THE 60 SERIES HAS ANOTHER GREAT PLUS POINT: GENTLE HANDLING.

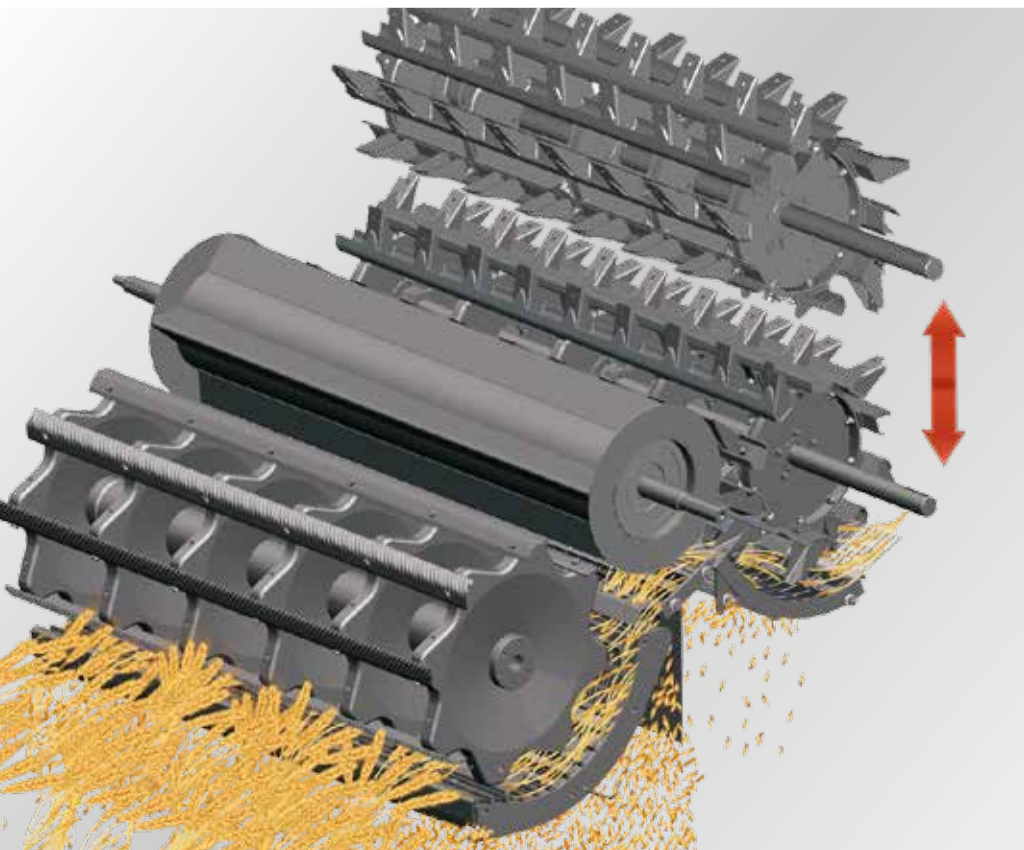

The threshing system of the DEUTZ-FAHR combines is sturdy, reliable and capable of extremely high productivity. The possibility to adjust the Turbo Separator (opt) to 5 different positions means that you can work with high productivity and maximum care on a wide range of different crops.



Deutz-Fahr combines can be adapted easily to harvest different crops, while ensuring top levels of performance whatever the conditions.



Optimum combining

With the 60 series, the historic effectiveness of the DEUTZ-FAHR threshing system has been raised to new and unequalled heights.

The threshing geometry of these new machines enables them to deliver extremely high output, while at the same time ensuring that grain and straw are handled gently and suffer no damage.

Segmented concave

With the optional exclusive DEUTZ-FAHR transverse segment system, the combine

ADVANTAGES

- ▶ Threshing system giving thorough early separation at the concave
- ▶ Generous 121° concave wrap angle
- ▶ Independent adjustment of drum to concave inlet and outlet clearance
- ▶ Turbo separator adjustable electrically through 5 positions
- ▶ 600 mm diameter threshing drum with 8 bars
- ▶ High performance segmented concave (opt.)
- ▶ Turbo Separator wear plates (opt.)
- ▶ Rubber tracks with 4 track roller with 716 and 915 mm belts
- ▶ Road width of 3.5 m with 762 mm track



can also be adapted swiftly to different crops and conditions during the harvesting season.

In practice, this solution allows the operator to select the spacing, between the rows of the different segments, that will be best suited to the harvesting conditions. By accentuating the threshing action at the drum inlet, and the separating action at the outlet, the operator can lighten the load on the straw walkers and minimize the quantity of short straw deposited on the sieves. With this type of setting, more than 90% separation is

achieved even before the material has left the drum – a guarantee of high productivity and high quality.

Turbo separator

With this centrifugal drum, the hourly output capacity of the combine harvester can be increased significantly. The turbo separator can generate increases up to 20% in productivity, whatever harvesting conditions are encountered. The benefit of the exclusive 5-position electric adjustment feature is that the separating action can be varied to suit

the characteristics of the threshed crop, and in the case of summer cereals, the quality of the straw is preserved for subsequent baling operations. For particularly abrasive crops, there is the option of fitting special wear-resistant plates to protect the teeth of the Turbo Separator.



CONSTANT AIR FLOW AND TWO RETURN PATHS. A TREMENDOUSLY CLEAN SAMPLE WITH NO UNNECESSARY GRAIN LOSS.



Another feature that illustrates the ease of maintenance characterizing 60 series machines is the one-piece preparation pan: the alternating motion of the pan has the effect of layering the crop in readiness for cleaning by the sieves; in addition, the preparation pan is easily removable from the front of the machine, to minimize servicing times.

The cleaning system has a large sieving surface (5.28 m² for 6060 and 6065 models; 6.32 m² for 6090 and 6095

models), a 44-blade cross-flow fan, and a sieve box with two cascade steps and adjustable pre-sieve, all combine to ensure that the grain delivered to the tank will be absolutely clean.

Another exclusive DEUTZ-FAHR feature is a returns system with two independent elevators, which ensures the crop will be distributed uniformly on the preparation pan, preventing overload to the threshing system and avoiding unnecessary waste. Any ears not already threshed by the drum

can be treated by two re-threshers, so that the grain returned to the preparation pan will be completely separated. Each of the re-threshers is equipped with a pair of special friction plates (adaptable to every type of crop, and interchangeable), guaranteeing top performance in all kinds of operating conditions.

There is also the option of electrical sieve adjustment, operated directly from the Commander Control. Top Line versions of the 60 series have a returns monitoring

ADVANTAGES

- ▶ Cross-flow fan delivering a constant flow of air to the sieves
- ▶ Opposed action sieve box and two cascade steps
- ▶ Sieve drive with improved balancing of moving parts (less vibration).
- ▶ Two return elevators, each equipped with re-thresher plates for gentle treatment of un-separated grain and then return it to the preparation pan
- ▶ Large grain tanks with capacities of 9500 litres
- ▶ Option of long discharge auger (5.6 m)
- ▶ New grain elevator lubrication system
- ▶ Electrically controlled sieves (optional)
- ▶ Returns level monitoring system (optional, depending on version)
- ▶ New sieve performance control sensor



With dual sensors and a control bar along the full length of the sieve box, the sieve performance control system allows precision monitoring of combine productivity



The folding coupling of the grain elevator greatly reduces the risk of crushing the grain."



Grain unloading is made quicker and easier by the camera directed at the discharge pipe and an unloading speed of 90 l/sec.

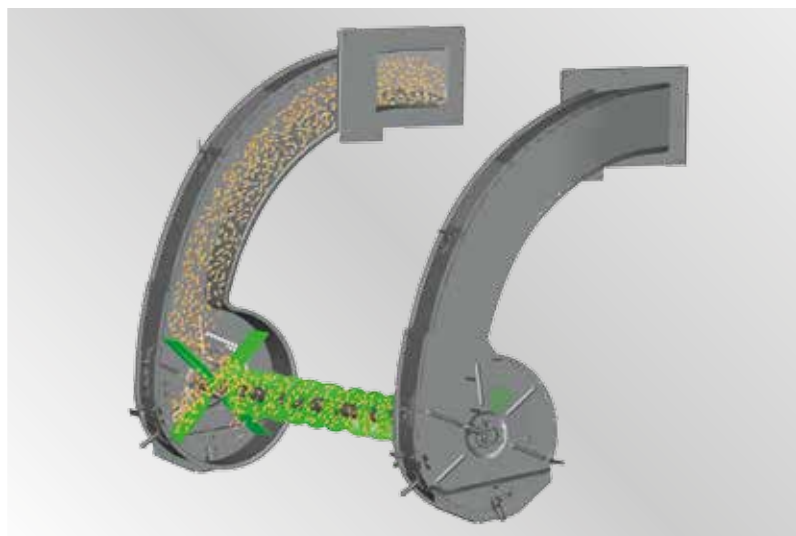

Returns system on both side of the combine: the returns system has two speed settings to ensure delicate handling with different grain types.

system as standard, for even greater precision in setting up and operating the machine.

Big volumes, fast unloading.

The grain tanks of DEUTZ-FAHR combines are proportioned to allow long, uninterrupted harvesting operations.

The tank capacity for 5 straw-walker machines ranges from 7500 litres on the 6060 to 8500 litres on the 6060 HTS and 6065 HTS, while the tank of a 6

straw-walker machine holds 9500 litres, also, a fast-emptying tank signifies shorter unloading operations, and with generous engine power available, trailers can be filled while harvesting continues, with no loss of productivity.

A combination of central discharge and movable auger ensures that all corners of the grain tank fill to capacity.

The hydraulically operated extension (models with 6 straw-walkers) is fast acting, and ensures that the tank remains sealed

tight when closed. The canvas sides provide strength and flexibility when the extension is closed.



**CHOPPED STRAW OR FLUFFY WIND ROWS.
WITH THE 60 SERIES, CUTTING AND SOIL
PREPARATION ARE ALL ONE**



ADVANTAGES

- ▶ High volume chopping rotor
- ▶ High performance built-in straw chopper
- ▶ Option of electrically controlled straw spreading action
- ▶ Highly efficient chaff spreader with 4-blade rotor and transport pan.
- ▶ Easy access to chopping knives for maintenance purposes

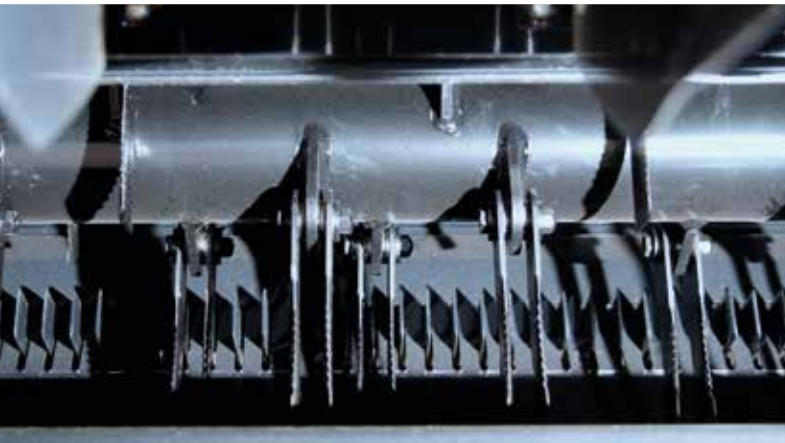

Adjustment and maintenance of the straw choppers is made quick and simple by easy access to both the stationary and the moving knife blades.



New chaff transfer pan with metal chutes that direct the chaff towards the 4-blade rotors.

A 60 series combine incorporating the new DEUTZ-FAHR high volume straw chopper can harvest the crop and leave the soil ready for subsequent tillage. The working width is such that the chopped material can be spread evenly over the entire surface created, even by the widest header. The straw chopper is operated directly from the cab, and is engaged before the threshing drum drive engages to avoid overloading the

transmission. With the knife blades easily accessible and the stationary blades extremely simple to adjust, the time spent on maintenance and set-up operations can be reduced to a minimum. There is also the option of an electric adjustment system for the straw chopper deflectors, which gives additional control over the spread of material so that its distribution can be adapted to

the prevailing conditions. The new chaff spreader with two 4-blade rotors and transfer pan is able to take material from the sieves across the same working width as the straw chopper, so that the straw and chaff can be mixed to the best possible advantage, thus providing a readily degradable organic residue.

**NEW DEUTZ TIER 4i ENGINES :
LOW FUEL CONSUMPTION AND TOP CLASS
PERFORMANCE.**

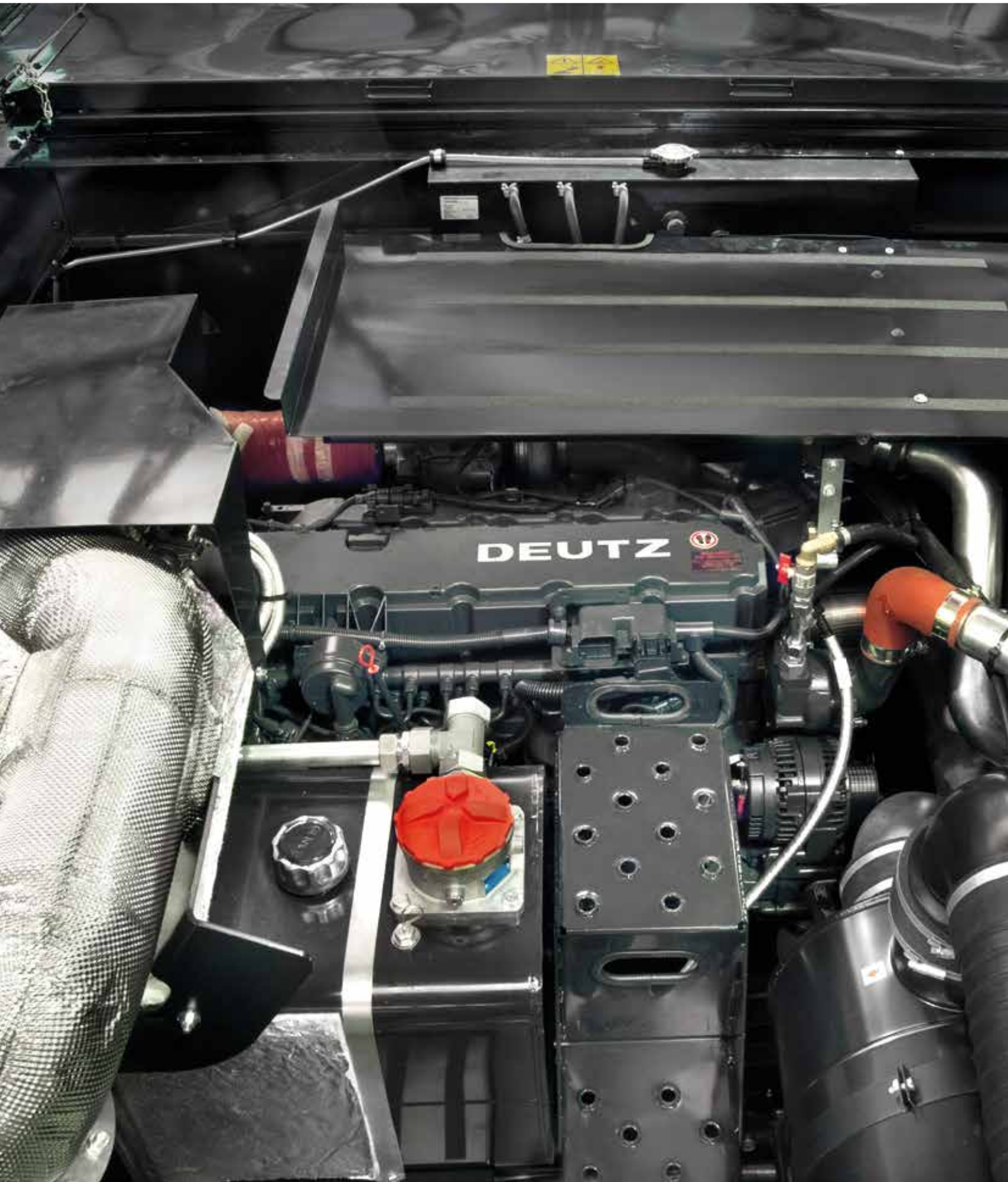

ADVANTAGES

- ▶ Tier 4i DEUTZ Common Rail, 24-valve engines deliver outstanding performance and fuel savings
- ▶ Power outputs range from 230 hp (169 kW) to 395 hp (290 kW)
- ▶ SCR (Selective Catalytic Reduction) technology with AdBlue® and fuel tank capacity of 750 litres (+35% operating hours)
- ▶ AdBlue® tank capacity of 85 litres
- ▶ Power take off from both ends of the engine: split take-off ensures better distribution of power, and a more compact machine
- ▶ Dedicated fan for cleaning the engine compartment
- ▶ Access platform for servicing radiators and coolers
- ▶ Hydrostatic transmission with 4 speed ranges: The right ratio for all situations
- ▶ Hydrostatic pump flange-mounted directly to the engine
- ▶ Load Sensing hydraulic system: Extra power delivered only when necessary, so that fuel is saved and more power made available to the threshing system

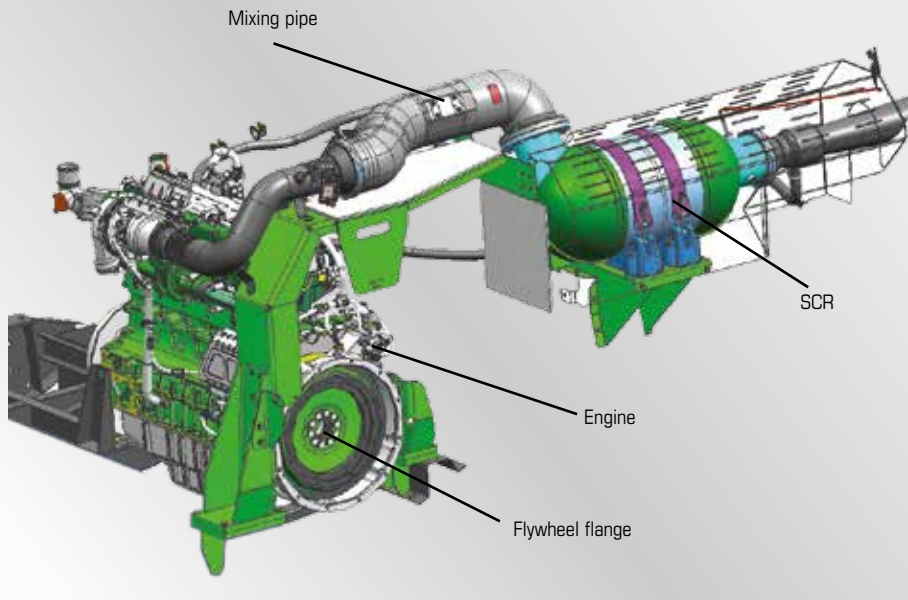

The fuel tanks and AdBlue® tank are made from 10 mm thick polyethylene.

A combine's engine must be not just sufficiently powerful to ensure that the machine's operational and performance capabilities are delivered to the full, it must also be able to power ancillary equipment, even under the toughest conditions, without compromising the speed of the threshing mechanism. .

Productivity and savings

DEUTZ Common Rail (DCR) engines are renowned for their high power, exceptional reliability and low fuel consumption, making each ton of grain harvested that much more profitable.. The two new Deutz TCD L6 6.1 and 7.8 litre T4i engines deliver high performance in the field, with power outputs of respectively 169 kW (230 hp) and 290 kW (395 hp), while ensuring fuel consumption is among the lowest for this class of machine. Equipped with common rail fuel injection, 24 valves and electronic control, these engines are able to deliver optimum power output, which is sustained even through overloads with no loss of productivity. The Tier 4i engines installed on DEUTZ-FAHR combines allow low hourly rates of fuel consumption while maintaining performance at the highest levels. The capacity of the 60 Series

fuel tank has been increased to 750 litres, ensuring 35% longer intervals between refuelling stops compared to previous models. The fuel and AdBlue® tanks of the Series 60 have been completely redesigned: 10 mm thick polyethylene and twin fixing points are indicative of an excellent construction quality and there is a more rational use of the available space to accommodate the urea tank. With the new Selective Catalytic Reduction (SCR) system, the new DEUTZ T4i engines are able to significantly reduce the quantity nitrogen oxide (NOx) emissions, which are one of the main pollutants found in combustion gases.

Series 60 machines are now fitted as standard with an auxiliary fan in the engine compartment, which serves to keep the hottest areas perfectly clean and to expel all dust particles.

Productivity and savings

The latest generation of liquid-cooled DEUTZ engines are renowned for high power and efficiency. With their combination of common rail fuel injection, 24 valves and electronic control, these engines are able to deliver optimum power out-

put, which is sustained even through overloads with no loss of productivity. Thanks to the high technological level of engines installed in DEUTZ-FAHR combine harvesters, hourly rates of fuel consumption are the lowest on record. This, together with a highly efficient threshing system, translates into a fuel consumption per tonne of threshed crop as low as any on the market for machines of comparable size and class.

A doubly efficient transmission system.

Another feature of these DEUTZ-FAHR machines is their compact transmission system, with power take-off from both ends of the engine. The design makes for swift and simple maintenance, and ensures optimum power output to the various drive components of the combine. Drive belts can be replaced easily and swiftly, so that less time is wasted and the harvesting operation benefits. The 60 series combine is more compact, and more maneuverable as a result.

**COMMANDER CAB IV.
FROM HERE, YOU DOMINATE THE FIELD
IN ABSOLUTE COMFORT.**



ADVANTAGES

- ▶ Setting and supervision of combine functions are managed by the Commander Control on-board computer
- ▶ Spacious and well-appointed cab, with superior driving comfort
- ▶ New on-board computer controlling the main production parameters of the combine
- ▶ Main control functions operated electrically
- ▶ All main header and driving functions controlled by way of the Commander Stick
- ▶ Header immobilized by pedal-operated switch in the event of emergency
- ▶ Excellent visibility of the work area
- ▶ Visibility Pack (opt.)
- ▶ Camera Kits (opt.) with colour cameras and 7" monitor
- ▶ A rear camera covering the area to the rear of the combine, one camera on the left-hand side aimed at the unloader, and one camera positioned to cover the tow hitch



The Commander Control is designed so that all adjustments to machine systems can be made simply and intuitively.



4-way 7" monitor for display of images from the IR and colour cameras.



With the Commander Lever, the operator has everything under control and can focus on the actual job of harvesting with greater freedom and comfort.



Rear camera directed at the towing hitch to facilitate hitching of the header transport trailer.



The new Combine Control Management system monitors performance of the machine in actual time.

The working conditions inside the new Commander Cab IV are superb, guaranteed to ensure the operator stays 100% alert and comfortable during long shifts.

Low noise levels, controls grouped together by function, optimum visibility – everything is designed so that the operator need focus attention only on the harvest, and the performance of the machine will benefit as a result.

The control instruments are:

- CCM (Combine Control Management)
- Commander Control
- AUTOCONTROL module
- Balance module

CCM

This is the optimum monitor for the operator to verify the quality of the work being done at any given moment.

Information visible at a glance:

- Ground speed
- Losses and returns
- Total and partial areas harvested
- Load on the engine

- Cutting height
- Total hours operation (engine and threshing system)

There is also a number of indicators and alarms that will warn the operator immediately of any malfunction developing in the machine.

COMMANDER CONTROL

This is the controller governing the threshing and cleaning systems. At the touch of a button, the operator can vary the working parameters instantly, guaranteeing constant productivity over the course of a given day, and throughout the harvesting season.

VISIBILITY PACK

For better visibility and closer control over harvesting operations at night time, there is now a generous selection of work lights available, offered in 5 different packages:

- Under-cab lights illuminating the area behind the cutter bar
- Handrail-mounted lights, suitable when using maize headers

- Lights mounted to the side access panels, for easier inspection of windrows when threshing after dark.

VISIBILITY PACK

Camera kits with up to 3 cameras to monitor the area around the combine.

All the cameras are colour and infra red, with images displayed on the new 7" monitor.

AGROSKY

The new 60 series combines can be equipped with the Agrosky GPS guidance system (optional), which will enable positioning accuracy down to 2cm. With Agrosky, the operator can focus entirely on the machine's harvesting functions, working in supreme comfort even with the widest of headers.

CC4
COMMANDER CAB

WHEN COMPONENTS ARE READILY ACCESSIBLE, THEY ARE EASIER AND QUICKER TO SERVICE.



The side-hinged design of the service panels on DEUTZ-FAHR combine harvesters sets a new standard in terms both of solid construction and, in particular, of accessibility. The exclusive idea of having side body panels split into two sections, and opening independently, is one that ensures total access to the various machine units making up the combine. The automotive style side-hinged design of the side panels makes them safe and easy to use and allows opening angles

from 40° to 180°. Whether for the purposes of everyday routine maintenance or major servicing and repairs, access to all parts is totally unimpeded. The rational layout, with hydraulic assemblies on the left hand side of the machine and mechanical on the right, will guarantee that any technical problems can be dealt with swiftly and economically. The new stainless steel ladder positioned under the body panels is positioned to

facilitate routine maintenance, without cluttering the machine or impacting negatively on the styling of the new 60 series. As an additional aid to practical and easy servicing, equipment options also include a set of inspection lights, with 4 lamps positioned two on each side of the machine, plus a lead light for close inspection of the engine and other internal components. And for operators who want every possible convenience,

ADVANTAGES

- All main components are accessible without difficulty, thanks to the side-hinged design of the service panels
- “Automotive” style side-hinged access panels
- Day-to-day maintenance made easy with
 - centralized lubrication
 - Option of automatic lubrication
 - Quick and simple maintenance
 - Movable ladder with dedicated fixing points provided on the combine
- 5 internal work lights for easy servicing (optional)
- Compressed air system for general daily cleaning of machine parts
- Automatic rear towing hitch with height adjustment (opt.)

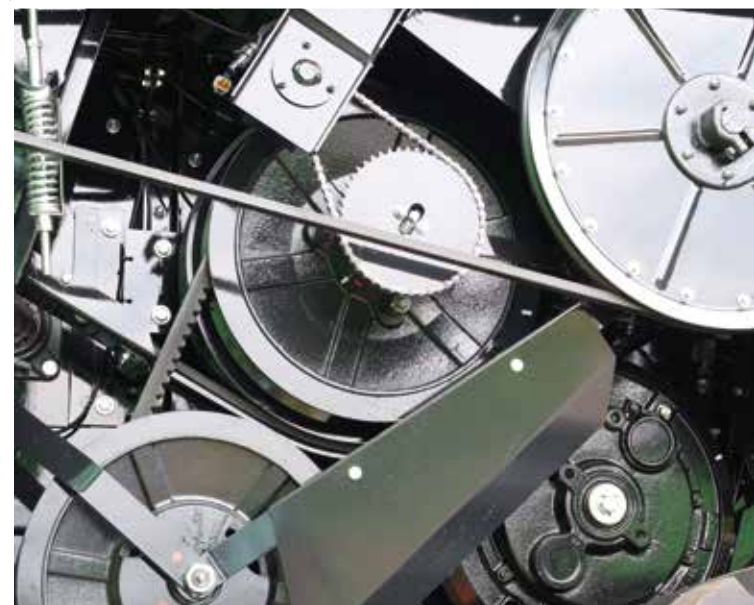

60 series machines can be fitted with a compressed air system (compressor and air lines, 3 outlets and a hand gun), so that routine cleaning and maintenance operations can be completed even more quickly.

The optional automatic rear towing hitch with height adjustment allows easy hitching of Deutz-Fahr header transport trailers.



DEUTZ-FAHR PARTS. YOUR DEUTZ-FAHR WILL ALWAYS BE 100% ORIGINAL.



OEM service: A reasoned choice

"Many can do much", as the saying goes, and this is certainly true of vehicle repairs. But only the DEUTZ-FAHR specialist dealer knows your machine inside-out, right down to the smallest detail. Only your authorized dealer has regularly trained, highly qualified service personnel, working with the professional tools and diagnostic equipment needed to perform every kind of servicing job correctly, and in complete safety.



Original parts: Quality that pays

Trust only DEUTZ-FAHR original replacement parts: these are parts that have undergone a rigorous selection procedure and stringent quality controls, ensuring the absolute efficiency of all components, to guarantee that your machine will keep running smoothly, for a very long time.



DEUTZ-FAHR

Series 60

Type	6060	6060 HTS	6065 HTS	6090 / 6090 HTS	6095 HTS
Header					
Cutting width	4,20-6,30		4,8-7,2	5,40-7,20	
Hydraulic cutting height adjustment	mm		From -300 to +1.370		
Cutting height indicator	standard				
Oil-immersed planetary knife drive (1,220 cuts/min)	standard				
Long right and left crop dividers, fixed	standard				
Number of crop lifters	13 to 23, depending on cutting width				
Automatic ground pressure adjustment, pre-selection of cutting height with height indicator	standard				
AUTOCONTROL (with lateral float)	*		standard	*	standard
Cutting angle adjustment (electrohydraulic)	on request (standard on Balance version)				
Trailer towing hitch	standard				
Header trailer	on request				
Hydraulic multi coupling	*		standard	*	standard
Automatic towing hitch	on request				
Rapeseed conversion kit for bar with side cutter on right operated by separate hydraulic control	on request				
Side cutter on left, operated by separate hydraulic control (for rapeseed header only)	on request				
Sunflower conversion kit for header	on request				

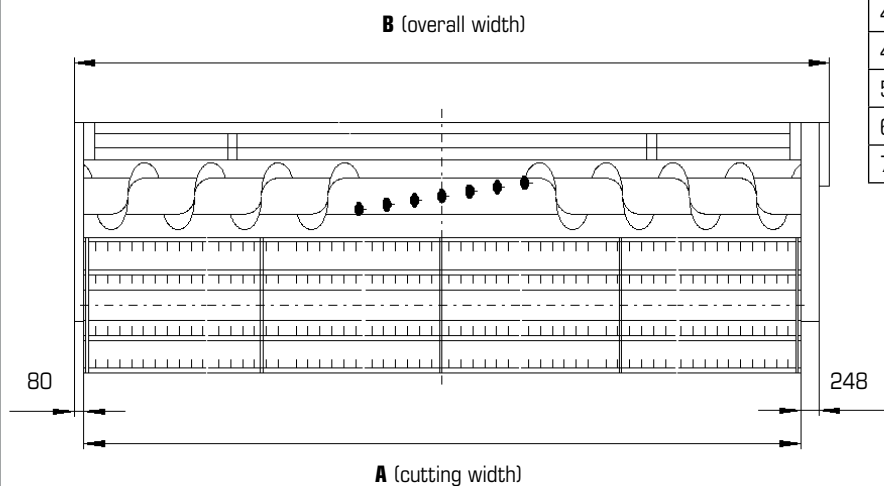

Type	A (mm)	B (mm)	Weight (kg)	Dimensions in mm
4,20 m	4.187	4.515	1.280	L = 480
4,80 m	4.796	5.124	1.420	D = 610
5,40 m	5.406	5.734	1.540	d = 350
6,30 m	6.320	6.648	1.760	h = 130
7,20 m	7.235	7.563	1.980	a = 50

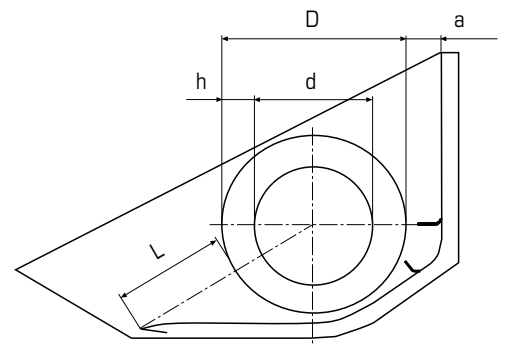

Pick-up reel					
6-bar reel with hydraulic height adjustment	standard				
Hydraulic fore/aft adjustment	standard				
Electric speed control	rpm	16 to 45, infinitely variable			
Automatic adaptation of reel speed to ground speed	standard				

TECHNICAL DATA

DEUTZ-FAHR

Series 60

Type		6060	6060 HTS	6065 HTS	6090 / 6090 HTS	6095 HTS
Threshing drum						
Diameter	mm	600				
Width	mm	1.270		1.521		
Bars	No.	8				
Electric variable speed control	rpm	420 - 1.250				
Threshing drum speed reducer (optional)	rpm	210 - 625				
Concave						
Bars	No.	15				
Wrap angle	degrees	121				
Separation area	m ²	0,95		1,13		
Stone trap, foldable		on request				
Crop de-awner with external side adjustment		standard				
Independent electrical adjustment of concave inlet/outlet gap		standard				
Conversion for maize harvesting, grain or CCM		on request				
Conversion for rice harvesting		on request				
Turboseparator (TS)						
HTS						
Diameter	mm	-	590	590	590	590
Speed of rotation	rpm	-	775/410	775/410	775/410	775/410
Adjustable through 5 positions from the cab (electrical control)		-	standard	standard	standard	standard
Separation area	m ²	-	0,81	0,97	0,97	0,97
Wear plates for heavy duty applications		optional (standard with rice-harvesting equipment package)				
Straw walkers						
Elements	No.	5			6	
Steps	No.	5	4	5	4	
Open straw walkers		standard				
Ball bearing supports		standard				
Straw Walker shaking area	m ²	6,35	5,60	7,60 (6,70 HTS)	6,70	
Total separation area	m ²	7,30	7,36	8,73 (8,80 HTS)	8,80	
Straw walker returns pan		standard				
Electronic straw walker speed control		standard				
Straw chopper - chaff spreader						
Built-in straw chopper with manually adjustable spread width		on request				
Electrical spread width adjustment		on request				
Built-in chaff spreader		on request				

* Optional - depending on versions

TECHNICAL DATA

DEUTZ-FAHR

Series 60

Type	6060	6060 HTS	6065 HTS	6090 / 6090 HTS	6095 HTS
Cleaning system					
High performance turbine fan			standard		
Pre-sieve			standard		
Sieve box illumination			standard		
Opposed action sieves			standard		
Total ventilated sieve surface	m ²	5,28		6,32	
Returns					
Electronic control of returns overload			(*)		
Independent right/left returns with rethreshing system			standard		
Grain tank					
Capacity	litres	7.500	8.500	9.500	
Unloading in any position			standard		
Visual and audible grain tank level indicator			standard		
Interior courtesy light			standard		
Grain sampling from driving position			standard		
Discharge outlet with 5,60 m length			on request		
Discharge rate			90 lt./sec.		
DEUTZ 4 Valve Common Rail Tier 4 engine		Deutz TDC L6 6.1 litres		Deutz TDC L6 7.8 litres	
Rated power (97/68/EC)	kW / hp	169/230	183 / 250	226/307	267/363
Maximum power (ECE R120)	kW / hp	184/250	211/287 (**)	211/287 (**)	290/395 (**)
Fuel tank	litres	750			
AdBlue® tank	litres	85			
Engine compartment cleaning fan		standard			
Transmission / Brakes / Steering					
Hydrostatic transmission with 4-speed gearbox				standard	
Forward speed*	km/h			0 - 30,0	
Reverse speed*	km/h			0 - 14,0	
Pedal operated hydraulic brake, usable as single brake, mechanical parking brake				standard	
"Balance" levelling system					
Complete levelling of the combine				on request	
Compensation for transverse/longitudinal slopes /				20%/6%	
Grain tank capacity	litres	7500		8500	

* Optional - depending on versions
 (**) Overboost is available during the harvesting and on-the-go unloading

TECHNICAL DATA

DEUTZ-FAHR

Series 60

Type	6060	6060 HTS	6065 HTS	6090 / 6090 HTS	6095 HTS
Tyres					
front, 620/75 R 30 168 A8	on request			-	
front, 650/75 R 32 167 A8				standard	
rear, 405/70 R 20 155 A2				standard	
front, 800/65 R 32 STR 172 A8				on request	
rear, 500/60 - 22.5 10 PR				on request	
front, 710/75 R 34 178 A8				on request	
rear, 600/50 R 22,5 165 A8				on request	
rear, 540/65 R 24 146 D				on request	
Rubber track with 4 roller undercarriage and 915 mm track				on request	
Rubber track with 4 roller undercarriage and 716 mm track				on request	
Cab					
CommanderCab III panoramic windscreen with tinted laminated glass, comfort driver seat with armrest, passenger seats				standard	
Commander Lever multifunction control				standard	
CommanderControl for convenient electrical operation of header, threshing system, concave, Turbo separator and grain tank discharge				standard	
CCM (Combine Control Management)				standard	
6 working headlights on cab roof, 1 working light on grain tank 2 rear working lights				standard	
Electrically adjusted mirrors, right and left				standard	
Work visibility pack: work lights on sides, under-cab and on handrail				on request	
Maintenance visibility pack: maintenance lights (4 on sides of combine, 1 in engine compartment)				on request	
Camera kits: 3 cameras (rear, discharge pipe and towing hitch), IR and colour, with 7" monitor				on request	
Heater and air conditioning				standard	
2 Xenon work lights				on request	
Safety components					
Safety clutch on top shaft of elevator, feed auger, reel, straw walker drive and grain auger				standard	
Electronic speed control on straw walkers, grain elevator and returns elevator				standard	
Header emergency stop				standard	
Maintenance					
Manual centralized lubrication system:					
Grease points: 8 on left, 6 on right				standard	
Automatic centralized lubrication system serving approx 60 lubrication points				on request	
IAir compressor with a pressure tank with a capacity of 30 l, three compressed air connections (one on each side and one				on request	

DEUTZ-FAHR

Series 60

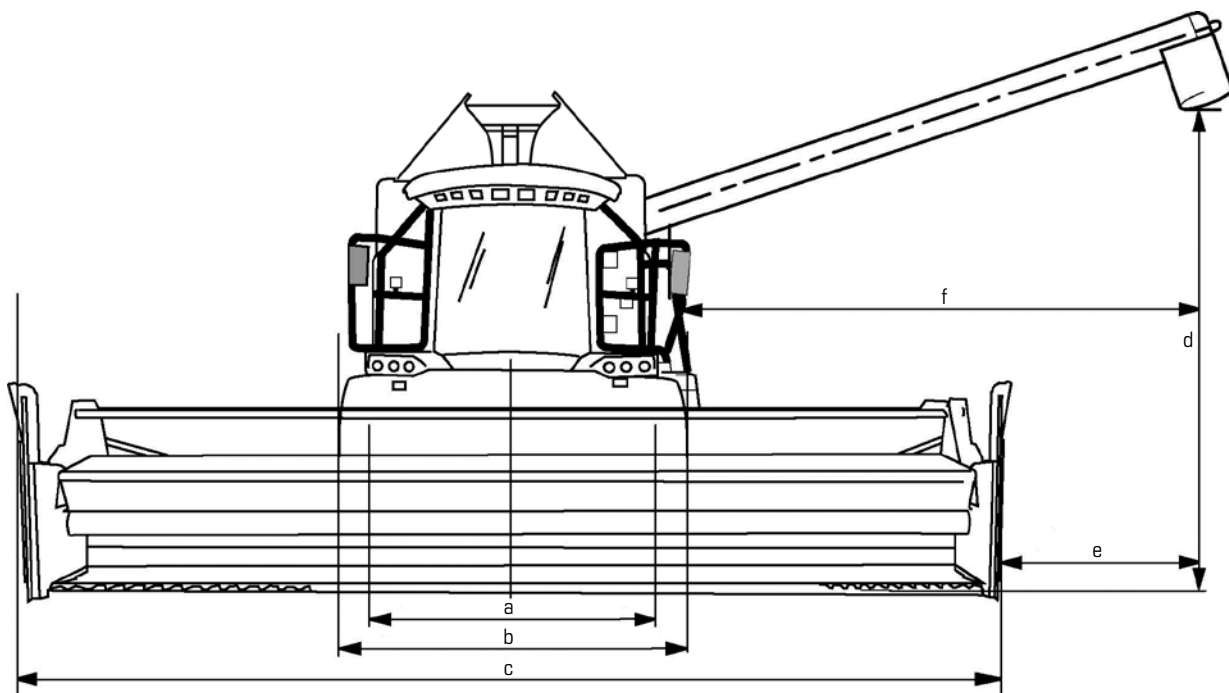

Type		6060	6060 HTS	6065 HTS	6090 / 6090 HTS	6095 HTS
Dimensions in mm						
a Track width ¹⁾	front			2.670		
	rear			2.343		
b Width ¹⁾ without header				3.285		
c Width with header	4,20m			4.515		
	4,80m			5.124		
	5,40m			5.734		
	6,30m			6.648		
	7,20m			7.563		
d Height at bottom edge of unloader with standard tyres				4.305		
e Distance between side wall of header and grain unloader	with 4.20 m cutter bar			2.330		
	with 4.80 m cutter bar			2.025		
	with 5.40 m cutter bar			1.720		
	with 6.30 m cutter bar			1.260		
	with 7.20 m cutter bar			800		
f Distance between unloader and left hand side wall of grain tank				4.180		

¹⁾ with 650/75 R 32 front tyres and 405/75 R 20 rear tyres.

DEUTZ-FAHR

Series 60

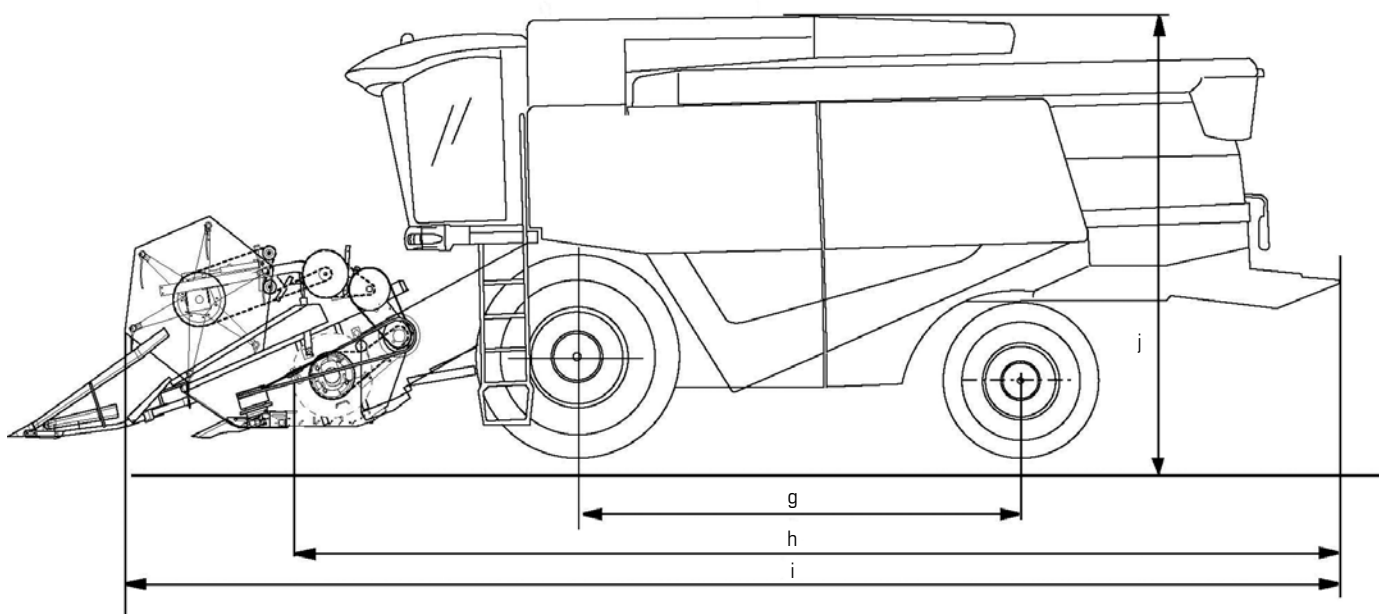

Type		6060	6060 HTS	6065 HTS	6090 / 6090 HTS	6095 HTS
Dimensions in mm						
g Wheelbase				3.892		
h Length without header				9.240		
i Length with header (crop divider folded)				10.890		
j Height at grain tank ¹⁾				3.990		
Weights						
without header	kg		10.570			11.070
with header 4,20m	kg		11.645			12.145
with header 4,80m	kg		11.740			12.240

¹⁾ with standard tyres



SURE AND SAFE WITH ORIGINAL DEUTZ-FAHR SERVICE AND PARTS.



Original service is wise.

Only your DEUTZ-FAHR specialist dealer knows your tractor inside and out. Only your dealer has regularly trained mechanics and experts on call. Only dealers have the special tools and diagnostic equipment required for competent diagnosis and inspection. All this gives you peace of mind – without doubt.

Original parts make good sense.

As you placed your trust in the original tractor, we recommend you use original parts when required. Only these comply with the high quality and safety standards of DEUTZ-FAHR and ensure correct function and operation without problems – guaranteed.

DEUTZ-FAHR lubricants

We recommend genuine DEUTZ-FAHR lubricants. The outstanding quality of this product range, which is made exclusively for DEUTZ-FAHR, ensures that your tractor always receives exactly what it needs.



Your DEUTZ-FAHR dealer will be pleased to answer your questions:

This printed material is designed for international use. The illustrations it contains show both special equipment and incomplete standard equipment. The availability of some illustrated models, standard and special equipment can vary from country to country. Only the dealer's price list stipulates whether such illustrated equipment is included as a standard feature or whether it is a special accessory. In addition the illustrated mounted implements and special accessories may not always comply with the respective statutory regulations. It is the responsibility of the customer – after consultation with the dealer – to verify this, taking the operating instructions into account. All information and illustrations in this brochure are subject to correction; errors excepted. Furthermore all information contained in this brochure is not binding and is subject to modifications of a technical and commercial nature or those resulting from statutory regulations. No claims whatsoever can be derived from these. SAME DEUTZ-FAHR DEUTSCHLAND GmbH reserves the right to make any changes to the design and technical construction and also the scope of standard equipment at any time and without prior notice.

Order no.: 308.8301.3.6-7 - 10/12 - CFV

 **SAME DEUTZ-FAHR**

SAME DEUTZ-FAHR DEUTSCHLAND GmbH, D-89415 Lauingen, www.deutz-fahr.de

