



Cat[®] 432F

BACKHOE LOADER

FEATURES:

The 432F is designed to exceed customer expectations with more performance, versatility and comfort than ever before.

Lower operating costs, improved weight distribution, optional lock-up torque converter and a choice of transmissions reduce travel and task time for maximum efficiency and productivity.

- **Operator Station** – Air suspension seat and ergonomic pilot operated joystick controls provide a comfortable working environment.
- **Service Access** – Fully opening engine hood and hinged cooling pack allow easy access for fluid checks and grouped fill points provide one position to check all fluids.
- **Load Sensing Hydraulics** – Electronic pump control provides better pump response for improved hoe and loader productivity, performance and power management.

- **Superior Power** – A larger torque converter delivers greater pushing power, increased aggressiveness in hard bank with faster roading and hill climbing.
- **Loader Performance** – New front loader arms deliver more reach, dump height and breakout.
- **Backhoe Design** – New robust swing casting and double clevis design improves durability and reliability.
- **Versatility** – A wide array of Cat Work Tools lets you do more jobs with one machine. The Cat quick coupler allows you to work faster with quick and easy work tool changes.

Specifications

Engine

Cat[®] 3054C Naturally Aspirated Diesel Engine*

	Standard	Optional
Rated gross power @ 2,200 rpm SAE J1995	69 kW (93 hp)	75 kW (101 hp)
Rated net power @ 2,200 rpm ISO 9249	65 kW (87 hp)	71 kW (95 hp)

Cat[®] C4.4 Turbocharged After Cooled Engine**

	Standard	Optional
Rated gross power @ 2,200 rpm SAE J1995	71 kW (95 hp)	75 kW (101 hp)
Rated net power @ 2,200 rpm ISO 9249	66 kW (88 hp)	71 kW (95 hp)

*EU Stage II compliant meets EU Emission Directive 97/68/EC.

**EU Stage IIIA EU Emission Directive 2004/26/EC.

Loader Bucket Dimensions and Performance

	General Purpose	Multi Purpose	Multi Purpose with Forks
Capacity (SAE rated)	1.00 m ³	1.03 m ³	1.03 m ³
Lift capacity at maximum height	3727 kg	3490 kg	3312 kg
Tilt breakout force	54 944 N	60 424 N	59 499 N
Maximum hinge pin height	3440 mm	3440 mm	3440 mm
Dump height at maximum angle	2730 mm	2758 mm	2758 mm
Dump reach at maximum angle	805 mm	731 mm	731 mm

Backhoe Dimensions and Performance

	Standard Stick	E-Stick Retracted	E-Stick Extended
Digging depth (SAE rated)	4306 mm	4344 mm	5303 mm
Reach from swing pivot at ground line	5652 mm	5661 mm	6583 mm
Loading reach	1684 mm	1700 mm	2490 mm
Bucket dig force	63 499 N	63 413 N	63 422 N
Stick dig force	35 401 N	35 952 N	26 414 N

Weights

Standard parallel lift loader, with 1.0 m ³ general purpose loader bucket, 610 mm standard duty backhoe bucket, 80 kg operator and a full fuel tank.	
Operating weight (range)	7294-11 000 kg
Standard machine weight	8988 kg

Hydraulic System

Type	Closed center
Pump type	Variable flow, axial piston
Pump capacity	158 L/m @ 2,200 rpm
System pressure	
Backhoe	250 bar
Loader	250 bar

432F Backhoe Loader

Transmission

The standard Power-Shuttle transmission provides four speed forward and reverse, full synchromesh in all gears. The optional auto-shift transmission can be operated in automatic or manual mode.

	Power-shuttle	Auto-shift
Forward		
1st	6 km/h	6 km/h
2nd	10 km/h	10 km/h
3rd	20 km/h	20 km/h
4th	40 km/h	27 km/h
5th	—	40 km/h
Reverse		
1st	6 km/h	6 km/h
2nd	10 km/h	10 km/h
3rd	20 km/h	27 km/h
4th	40 km/h	—
5th	—	—

Lock-up torque converter

The optional lock-up torque converter is automatically selected dependent on ground speed and enables speed to be maintained longer over all types of terrain.

Steering

Type	Front Wheel Hydrostatic
Power steering	
Cylinder, one (1) double-acting (AWD)	
Bore	65 mm
Stroke	120 mm
Rod diameter	36 mm
Turning circle	
Inner wheel not braked 4WD	
Outside front wheels	8180 mm
Outside widest loader bucket	10 970 mm

Service Refill Capacities

Cooling system	
With heater	22 L
Fuel tank	160 L
Engine with oil filter	7.6 L
Transmission	
Power Shuttle AWD	18.5 L
Rear axle (rigid/steerable)	
Center housing	16.5 L
Center housing additive	0.5 L
Wheel end/final drive (volume per side)	1.7 L
Front axle AWD	
Center housing	11 L
Wheel end/final drive (volume per side)	0.7 L
Hydraulic system	95 L
Hydraulic tank	42 L

Brakes

- Inboard oil-immersed, hydraulically actuated multiple Kevlar discs on final drive input shaft.
- Completely enclosed and sealed.
- Self-adjusting.
- Foot-operated brake pedals can be interlocked for roading.
- Parking/secondary brakes are independent of the service brake system. Parking brake is mechanically applied through a hand lever located in the right side console.
- Meets ISO 3450:1996 requirements.

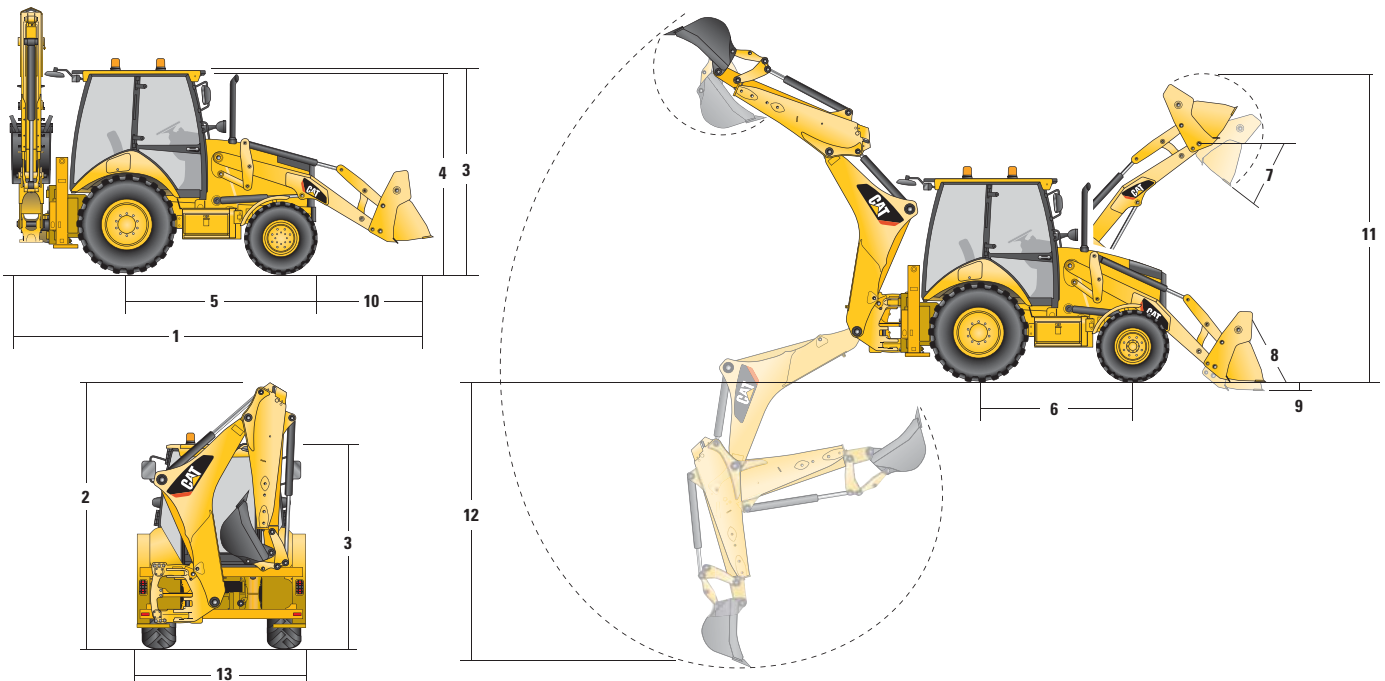

Machine Dimensions

	GP	Standard MP	MP with forks
1 Overall length (loader on ground) S-Stick	7345 mm	7294 mm	7319 mm
Overall length (loader on ground) E-Stick	7428 mm	7377 mm	7403 mm
Overall transport length S-Stick	6004 mm	5972 mm	5972 mm
Overall transport length E-Stick	6004 mm	5972 mm	5972 mm
2 Overall transport height (standard stick)	3717 mm	3717 mm	3717 mm
Overall transport height (extendible stick)	3740 mm	3740 mm	3740 mm
Overall width	2406 mm	2406 mm	2406 mm
3 Height to top of cab/canopy	2863 mm	2863 mm	2863 mm
4 Height to top of exhaust stack	2744 mm	2744 mm	2744 mm
Height to loader hinge pin (transport)	390 mm	392 mm	392 mm
Ground clearance (minimum)	320 mm	320 mm	320 mm
5 Rear axle centerline to front grill	2705 mm	2705 mm	2705 mm
Front wheel tread gauge	1826 mm	1826 mm	1826 mm
Rear wheel tread gauge	1707 mm	1707 mm	1707 mm
6 Wheelbase 2WD/AWD	2200 mm	2200 mm	2200 mm

Dimensions and Performance – Loader Bucket

	GP	Standard MP	MP with forks
Width	2406 mm	2406 mm	2406 mm
Lift breakout force	55 244 N	53 692 N	52 043 N
Tipping load at breakout point	6684 kg	7100 kg	6514 kg
7 Dump angle at full height	46°	46°	46°
8 Maximum bucket rollback at ground level	38°	39°	39°
9 Digging depth	121 mm	154 mm	154 mm
Maximum grading angle	113°	116°	116°
Width of dozer cutting edge	—	2406 mm	2406 mm
10 Grill to bucket cutting edge, carry position	1503 mm	1477 mm	1477 mm
11 Maximum operating height	4337 mm	4370 mm	4826 mm
Jaw opening maximum	—	790 mm	790 mm
Bucket jaw clamping force	—	61 N	61 N
Weight (does not include teeth or forks)	428 kg	611 kg	871 kg

Dimensions and Performance – Backhoe

	Standard	E-stick Retracted	E-stick Extended
Digging depth, manufacturer's maximum	4882 mm	4887 mm	5775 mm
12 Digging depth, 2440 mm flat bottom	3922 mm	3965 mm	4994 mm
Digging depth, 610 mm flat bottom	4263 mm	4301 mm	5262 mm
Digging depth, 610 mm flat bottom, manufacturer's	4865 mm	4870 mm	5803 mm
Reach from rear axle centerline at ground line	6742 mm	6751 mm	7673 mm
Maximum operating height	5660 mm	5606 mm	6262 mm
Loading height	3985 mm	3944 mm	4595 mm
Swing arc	180°	180°	180°
Bucket rotation	205°	205°	205°
13 Stabilizer spread, operating position (center)	2352 mm	2352 mm	2352 mm

432F Backhoe Loader

STANDARD EQUIPMENT *(Standard equipment may vary. Consult your Cat dealer for details.)*

- Air cleaner, axial seal with precleaner and filter condition indicator
- Alarm, back up
- All Wheel Drive
- Alternator, 120-amp, 12 volt
- Antifreeze (to -37° C)
- Audible system fault alarm
- Backhoe, 4422 mm dig depth, side-shift, excavator-style backhoe
- Battery, maintenance free, 750 CCA
- Boom, transport lock
- Brace, lift cylinder
- Brakes, boosted, Kevlar disc, oil immersed
- Cat 3054C* (68.5 kW) engine or Cat C4.4** (70 kW) engine
- Coat hook
- Drain ecology
- Electro-hydraulic slide frame lock
- Engine enclosure
- Fan, cooling and fan guard
- Fast reversing shuttle, all gears
- Flashing hazard/signal lights
- Floor mat, rubber
- Front axle, pendulum mount
- Front grill with bumpers
- Front headlights
- Gauges: coolant temperature, fuel level, tachometer, hour meter
- Ground line fuel fill with 160 L capacity
- Grouser style stabilizer shoes
- High ambient cooling package
- Hydraulic oil cooler
- Indicators: air cleaner service, brake on, engine coolant, hydraulic oil level, sight gauge
- Instrument panel lights
- Intermittent front and rear wash/wipe
- Key start/stop system with auxiliary position
- Left side doors with lock
- Lifting eye, backhoe (non EU countries only)
- Lights, working (4 front, 4 rear)
- Load sensing, variable flow system with axial piston pump
- Mirrors, external (2)
- Pilot stabilizer controls
- Power receptacle, 12 V (2)
- Power steering, hydrostatic
- ROPS cab with heater, defroster, pressurizer and cab recirculating fan
- Seat belt, retractable (50 mm)
- Seat, air suspension with fabric or vinyl seat cover
- Self-cancelling directional indicator
- Spin-on fuel, engine, hydraulic and transmission oil filters
- Starting system, thermal aid
- Stop and tail lights (2)
- Swing transport lock
- Tires (2 front, 2 rear)
- Torque converter
- Throttles, hand and foot
- Transmission, four-speed synchromesh
- Transmission neutralizer switch
- Warning horn, front electric
- Water separator

*Standard for less regulated countries, meets Stage II EU Emission Directive 97/68/EC.

**Standard for regulated countries, meets Stage IIIA EU Emission Directive 2004/26/EC.

OPTIONAL EQUIPMENT

- Air conditioning
- Attachments, front loader
 - General purpose bucket 1.0 m³
 - Multi purpose bucket 1.03 m³ or 1.03 m³ with forks
- Attachments, backhoe buckets
- Auto-shift transmission
- Quick Coupler (mechanical)
- Battery, additional
- Cat 3054C DIT* engine (74.5 kW)
- Cat C4.4** (74.5 kW) engine
- Counterweights
 - Bumper
 - Base
- Cutting edge, bolt on
 - Single piece
 - Two piece
- Fenders, front, All Wheel Drive
- Guards
 - AWD driveshaft
 - Teeth (GP/MP)
 - Rear lights, roading
- Hydraulic valves, loader
 - 3rd valve for GP/MP
- Hydraulic valves (auxiliary)
- Standard stick
- Extendible stick
- Hydraulic lines
- Hammer lines to stick
- Quick disconnects
- Lights
- Lock-up torque converter (only available with auto-shift transmission)
- Number plate, rear
- Roading
- Mirror, exterior rearview, large
- Object handling installation, including lifting eye, boom and stick locks, audible and visual warning system
- Powered side shift
- Ride control
- Rotating beacon
- Stabilizer street pads
- Tilt steering wheel
- Tool box, external
- Transport locks
- Vandalism protection
- Visor cab

*Standard for less regulated countries, meets Stage II EU Emission Directive 97/68/EC.

**Standard for regulated countries, meets Stage IIIA EU Emission Directive 2004/26/EC.

For more complete information on Cat products, dealer services, and industry solutions, visit us on the web at www.cat.com

AEHQ6706 (03-12)

© 2012 Caterpillar
All Rights Reserved
Printed in U.S.A.

Materials and specifications are subject to change without notice. Featured machines in photos may include additional equipment. See your Cat dealer for available options.

CAT, CATERPILLAR, SAFETY.CAT.COM, their respective logos, "Caterpillar Yellow" and the "Power Edge" trade dress, as well as corporate and product identity used herein, are trademarks of Caterpillar and may not be used without permission.

