

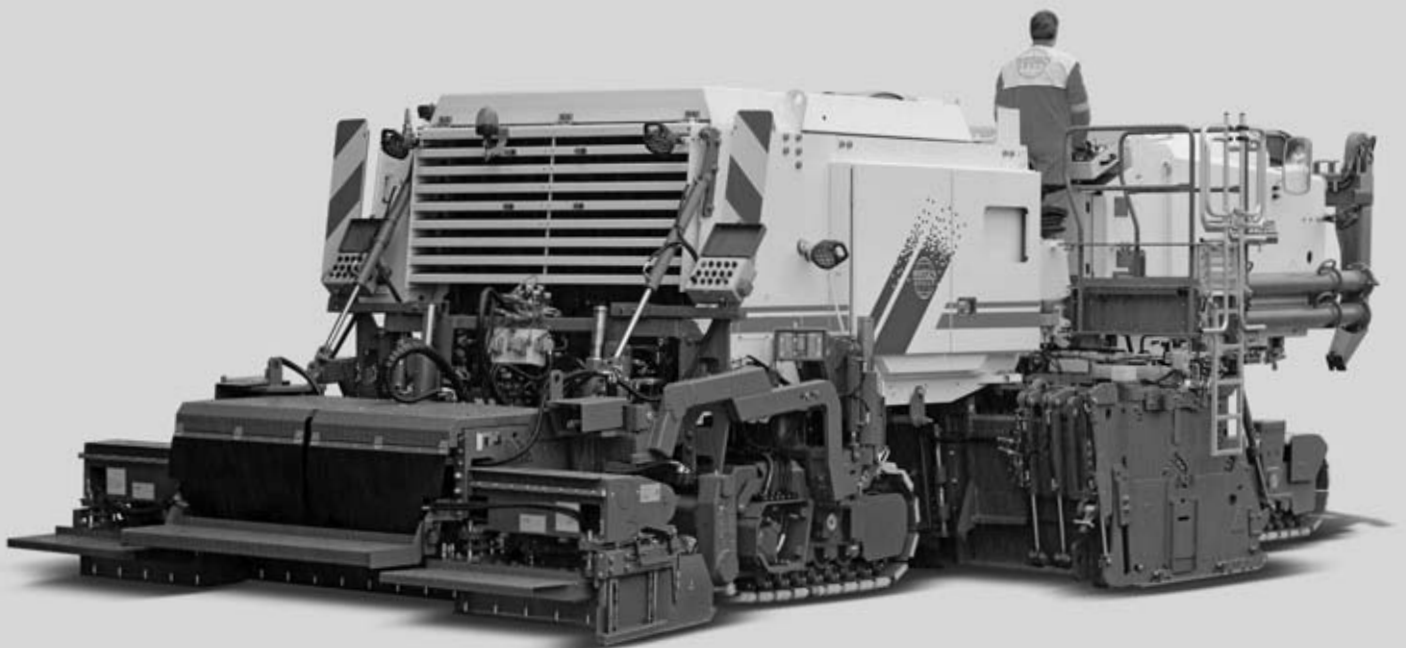

Technical specification

Cold recycler 3800 CR



	Cold recycler 3800 CR without spreading auger and paving screed	Cold recycler 3800 CR with spreading auger and paving screed
Working width	3,800 mm	3,800 mm
Milling depth / Recycling depth *1	0–350 / 0–150 mm	0–350 / 0–150 mm
Milling drum		
Tool spacing	15 mm	15 mm
Number of tools	186	186
Drum diameter with tools	1,140 mm	1,140 mm
Drum inclination, max.	5°	5°
Engine		
Manufacturer	Caterpillar	Caterpillar
Type	C27 ATAAC	C27 ATAAC
Cooling	Water	Water
Number of cylinders	12	12
Output	708 kW/950 HP/963 PS	708 kW/950 HP/963 PS
Engine speed	2,100 min ⁻¹	2,100 min ⁻¹
Displacement	27,000 cm ³	27,000 cm ³
Fuel consumption, full load	187 l/h	187 l/h
Fuel consumption, 2/3 load	125 l/h	125 l/h
Speeds / Gradeability		
Travel speed	0–84 m/min (0–5 km/h)	0–84 m/min (0–5 km/h)
Theoretical gradeability	90 %	90 %
Ground clearance	370 mm	370 mm
Weights *2		
Front axle load, full tanks	31,920 daN (kg)	29,660 daN (kg)
Rear axle load, full tanks	26,440 daN (kg)	33,290 daN (kg)
Own weight	52,010 daN (kg)	56,610 daN (kg)
Operating weight, CE *3	55,270 daN (kg)	59,870 daN (kg)
Operating weight, full tanks	58,350 daN (kg)	62,950 daN (kg)
Crawler track units		
Crawler tracks, front (L x W x H)	2,200 x 370 x 790 mm	2,200 x 370 x 790 mm
Crawler tracks, rear (L x W x H)	2,200 x 370 x 790 mm	2,200 x 370 x 790 mm
Tank capacities		
Fuel tank	1,400 l	1,400 l
Hydraulic fluid tank	500 l	500 l
Water tank	5,000 l	5,000 l
Electrical system	24 V	24 V
Conveyor system		
Belt width 1 st conveyor (primary conveyor)	1,100 mm	1,100 mm
Belt width 2 nd conveyor (discharge conveyor)	1,100 mm	1,100 mm
Theoretical capacity of discharge conveyor	668 m ³ /h	668 m ³ /h
Shipping dimensions / Weights *2		
Dimensions of machine without milling drum assembly (L x W x H)	9,700 x 2,800 x 3,000 mm	12,000 x 3,000 x 3,000 mm
Dimensions of discharge conveyor (L x W x H)	8,700 x 1,700 x 1,300 mm	8,700 x 1,700 x 1,300 mm
Milling drum assembly FB 3,800 (L x W x H)	4,400 x 2,950 x 2,250 mm	4,400 x 2,950 x 2,250 mm
Front weight (L x W x H)	1,800 x 1,700 x 1,000 mm	1,800 x 1,700 x 1,000 mm
Weight of machine without milling drum assembly	32,100 daN (kg)	36,700 daN (kg)
Weight of discharge conveyor	1,800 daN (kg)	1,800 daN (kg)
Weight milling drum assembly FB 3,800	16,600 daN (kg)	16,600 daN (kg)
Weight of front weight	3,500 daN (kg)	3,500 daN (kg)

*1 = The maximum milling depth may deviate from the value indicated, due to tolerances and wear.

*2 = All weights refer to basic machine without any additional equipment.

*3 = Weight of machine with half-full water tank, half-full fuel tank, driver (75 kg) and tools.

Cold recycler 3800 CR with discharge conveyor Dimensions in mm

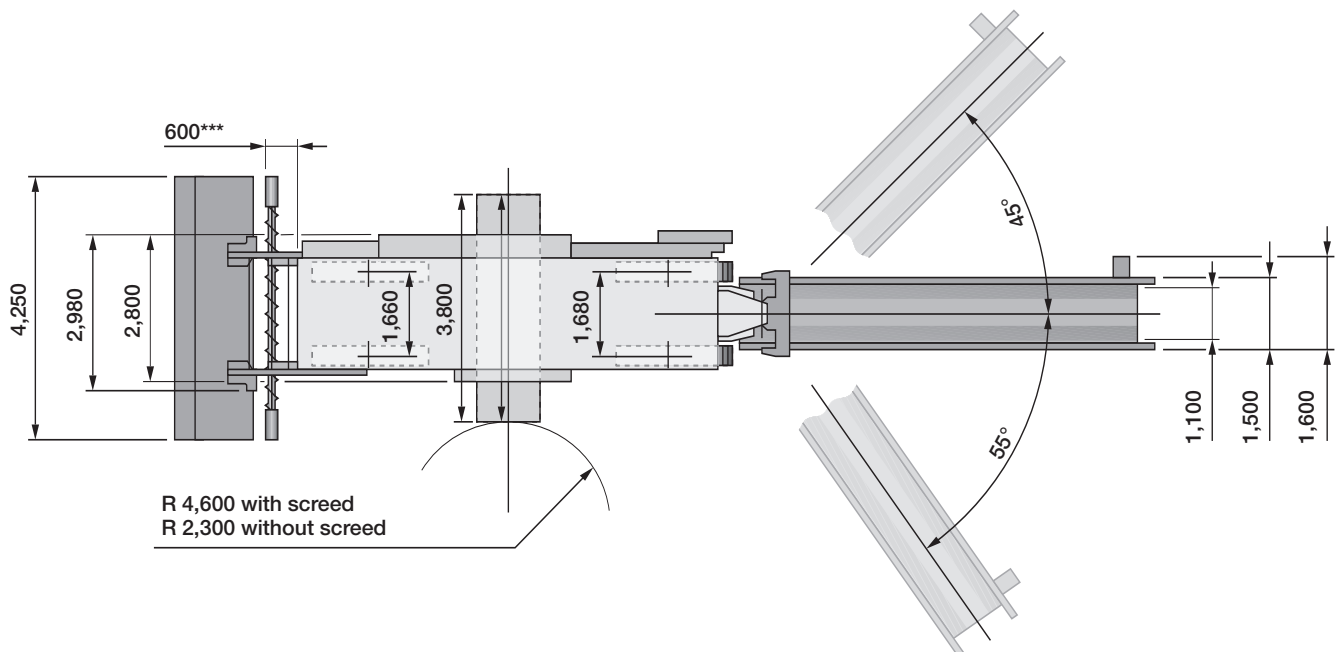
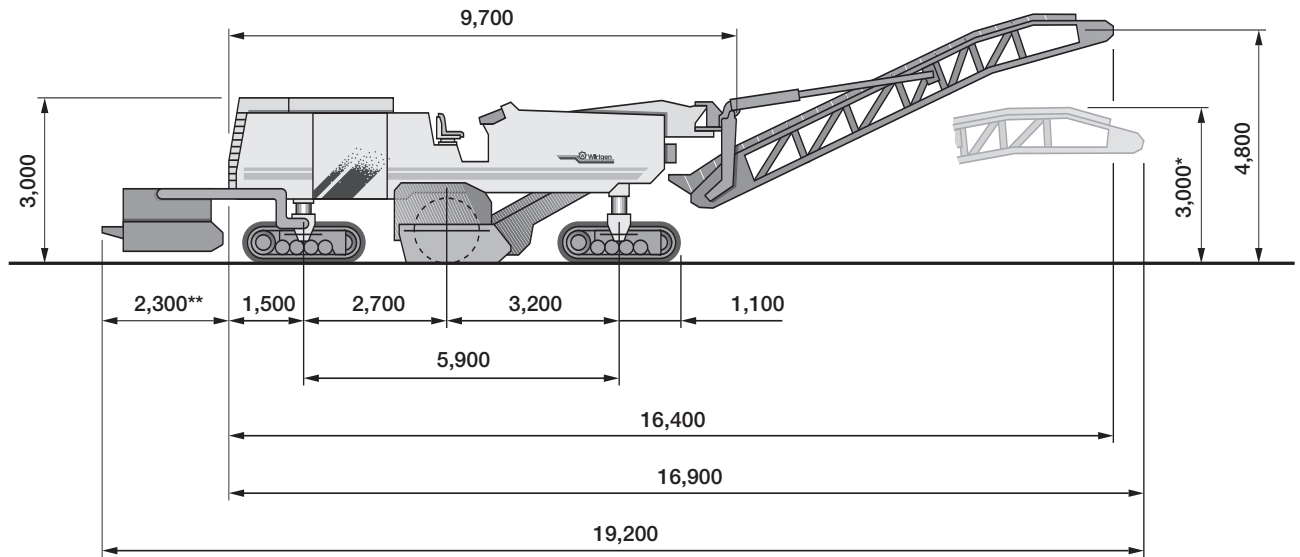

- * = Dimensions for low-loader transport
- ** = Screed and auger
- *** = Auger

Cold recycler 3800 CR with front weight, without discharge conveyor

Dimensions in mm

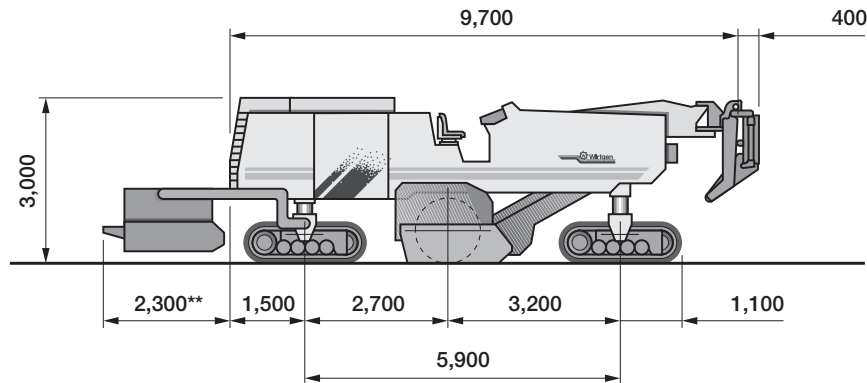

Basic design

The 3800 CR is a cold recycler with a mechanically driven milling drum and two-stage material conveying system. The front loading discharge conveyor can be slewed to both sides and adjusted in height. The machine travels on crawler tracks. The machine can also be operated as a road milling machine.

Chassis

Robust welded construction with mounts for the individual function modules and superstructures. The tanks for diesel fuel and water are integrated into the chassis. The hydraulic fluid tank forms a separate unit. The hydraulically opening engine cowling, wide opening servicing doors left and right, and optimum arrangement of the individual components ensure easy access for maintenance and servicing.

Operator's platform

The walk-through operator's platform with access ladders left and right is located at the centre of the machine. It is equipped with two identical control consoles which can be pivoted and adjusted in height. Both control panels and the right-hand driver's seat can be

moved to project over the outer edge of the machine chassis.

The control elements are located within easy reach and within the operator's field of vision.

The operator's platform includes a display of the Wirtgen information and diagnosis system for monitoring the operating status of the machine.

The ergonomic sitting position, clear overview and elastically supported footboards of the operator's platform help to make the operation of the machine simple and convenient. Steering and advance speed are governed by means of electrical proportional control and are operated via joysticks.

Wirtgen information and diagnosis system and instruments

The Wirtgen information and diagnosis system WIDIS 32 provides the driver with quick and comprehensive information on the current status of the engine and the hydraulic system, generating visual and audible alarms, if necessary. Data and messages are indicated on a multi-functional display (LC display) at the operator's platform. Other information, such as operating hours, engine speed or filling level of the diesel tank can be accessed here, too.

The hydraulic system is additionally monitored by two pressure gauges which indicate the actual pressures in 12 different areas of the hydraulic system.

The air filters and the filters of the hydraulic system are monitored electrically.

Power unit

The machine is driven by a modern V 12 engine with a power rating of 708 kW / 963 PS.

The engine complies with the stringent requirements of the exhaust emission standards stipulated by the US Environmental Protection Agency (EPA, Tier II).

It is equipped with a fully electronic engine management system which allows the engine to automatically adapt to varying ambient conditions, such as changing atmospheric pressure, temperature or humidity.

The engine offers maximum torque stability even at extreme engine loads, thus preventing breaks in operation.

An extremely large cooler surface effectively cools the engine, thus allowing the safe operation of the machine even at high outside temperatures.

The cooling system is additionally equipped with a fan controller. The fan speed is reduced at low ambient temperatures or low loads, thus reducing the noise emission levels. All servicing work on the engine can be carried out from the ground.

Soundproofing

Noise levels are reduced by the standard soundproofing which also protects both the operating personnel and the environment against any nuisance due to noise.

Milling drum drive

The milling drum is driven mechanically by the diesel engine via a mechanical clutch and power belts acting on the drum gearbox.

Three power belts with five ribs each ensure optimum power transmission due to their width, and have a long service life. The tension of the power belts is automatically maintained by two hydraulic cylinder.

Milling drum

The milling drum can be operated in both up-milling and down-milling mode. Altering the direction of rotation

requires the gearbox to be exchanged and the milling drum to be turned.

Toolholders accommodating the point-attack cutting tools are welded onto the drum body. Special edge segments ensure a clean sharp cut at the edges.

Ejectors on the milling drum ensure an efficient transfer of the milled material from the milling chamber.

As an option, the milling drum can be equipped with the patented and established quick-change toolholder system HT11.

In this case, the bottom parts of the toolholders are welded to the drum body and the upper parts secured to the bottom parts by retaining bolts to allow quick replacement.

Water spray system

The formation of dust clouds at the milling drum during the milling operation is largely prevented by a hydraulically operated water spray system, which also cools the point-attack cutting tools, thus considerably extending their service life.

The spray nozzles are easily removed for cleaning.

Refilling is required only occasionally due to the generously dimensioned water tank.

Gradation control beam

The gradation control beam is available as an equipment option and largely prevents the asphalt from breaking into large slabs.

At the same time, the position of the gradation control beam has an influence on the size of the milled material.

The gradation control beam additionally protects the primary conveyor against premature wear and tear.

Cutting tool replacement

The scraper blade opens hydraulically to provide good access to the milling drum for the replacement of tools, which can be carried out in a comfortable working position.

Material guiding system

A system of guide plates directs the milled material, which may be enriched with a binding agent, between the rear crawler tracks of the machine.

The front drum door, through which the material is normally loaded during the milling operation, is hydraulically closed by means of a flap.

Cold recycling system:

Injection system for water or binding agents

The standard injection system consists of a microprocessor-controlled metering unit, an eccentric pump and an injection bar with 12 nozzles and feeding device.

The pump delivers the liquid additive (e.g. water or bitumen emulsion) from a tanker truck or, in case of water, from the integrated tank of the machine to the injection bar.

The eccentric worm pump has a maximum delivery rate of 400 l/min. A flow meter monitors the delivered quantities and transfers the data to the microprocessor control, which in turn regulates the process in accordance with the pre-selected parameters and monitors the advance speed as well as the added quantities of binding agents or water in percent by mass and litres per minute.

The operating console for the microprocessor control unit can be positioned either at the operator's platform or at the rear left of the machine to allow operation from the ground. An automatic shut-off device enables the individual nozzles to be opened and closed by means of hydraulic cylinders, thus allowing the addition of binding agents to be effectively adapted to the working width.

The nozzles are cleaned automatically.

Injection system with second injection bar

An additional injection bar can be integrated for the purpose of adding a water-cement slurry from a preceding slurry mixer with integrated pump.

Injection system with second pump and second injection bar

This specification uses separate pumps to feed two different agents into the mixing chamber. So for example it is possible to inject water via the first injection bar and bitumen emulsion via the second injection bar.

Injection system for foamed bitumen

The injection system for foamed bitumen comprises a pump and an injection bar for foamed bitumen.

Foaming takes place in special expansion chambers in the injection bar. The hot bitumen is delivered by an electrically heated gear pump at a maximum rate of 500 kg/min, and is subsequently filtered. A flow meter registers the delivered quantity of bitumen.

A flow meter registers the delivered quantity of bitumen.

The addition of water and air, which are necessary for the foaming process, is governed in accordance with the bitumen quantity. The injection bar with 18 nozzles enables optimal injection of foamed bitumen into the mix across the entire working width. The system is equipped with a test nozzle to permit checks of the bitumen quality during the foaming process. A second injection system is provided for the addition of water to achieve the optimum moisture content of the mixture. It consists of an eccentric pump and an injection bar for water. The water can be supplied either from the water tank of the machine or from a preceding water tanker. Alternatively, a cement-water slurry can be injected from a preceding slurry mixer.

Spreading auger

The centrally divided spreading auger with scraper is equipped with high-strength interchangeable segments. The scraper blade ensures optimal proportioning of the material in front of the paving screed.

Both sections of the spreading auger can rotate in clockwise or anti-clockwise direction.

The speed of the auger is infinitely variable, and it can be infinitely adjusted in height by means of hydraulic cylinders.

Variable screed

The variable screed with tamper (working width max. 4.25 m) places and pre-compacts the processed material true to line and level.

Levelling of the screed is effected by means of hydraulically operated spindles left and right. The entire screed can be raised hydraulically for transport purposes.

Crawler track units/Height adjustment of the machine

The crawler tracks are suspended from the chassis by means of cylindrical columns with hydraulic height adjustment.

The milling depth is adjusted via the two front columns, while the rear crawler tracks act as a full floating axle.

The large stroke provides a large ground clearance.

Travel drive

The cold recycler is equipped with large crawler tracks (5 HD) lined with polyurethane track pads.

Each crawler track is driven by its own hydraulic motor. The travel drive motors are fed by a common hydraulic variable displacement pump. The desired tension of the crawler tracks is set and maintained hydraulically. The crawler tracks are driven automatically, thus dispensing with the need to change between milling and travel gear. The speed can be infinitely varied from zero to maximum speed.

A switchable hydraulic flow divider acts as differential lock and ensures uniform traction even under difficult conditions. Any speed once driven can be saved in a "Tempomat" speed control and re-set, for instance, after a stop.

Automatic power control

The machine is equipped with an automatic power control which governs the advance speed in accordance with the engine load, but can also be deactivated.

Steering

The machine has a finger-light hydraulic all-track steering system, which can be operated from both the right or the left side of the operator's platform.

It is governed by means of proportional control, and the front and rear tracks are steered separately via joysticks.

The steering function is detached from the height adjustment by specially designed steering rings.

Tight locking angles permit an extremely small turning clearance circle.

Four-track steering: The following steering modes can be pre-selected: Crab steering and coordinated steering as well as straight-ahead steering for the rear crawler tracks.

The rear crawler tracks can be positioned to zero automatically.

Brake system

Braking is achieved by the self-locking hydrostatic transmission.

The cold recycler is additionally equipped with two automatic multiple-disk parking brakes at the front.

Loading the milled material

When used as a cold milling machine, loading of the milled material from the milling chamber on trucks is effected to the front (front loading) by means of a wide conveyor system consisting of a primary conveyor and a discharge conveyor. The discharge conveyor is covered to prevent clouds of dust

being blown away by the wind and causing a nuisance. It can load trucks from a great height, is height-adjustable and can be slewed to both sides.

The high conveying speed and 1,100 mm wide, V-ribbed steep-incline belts ensure that the material is quickly removed from the drum housing.

Milling depth control/Automatic levelling system

The cold recycler is equipped with an electronic automatic levelling system for milling depth adjustment. It is governed by means of proportional control, meaning that changes in the reference plane are compensated quickly and without overshooting of the machine.

The reference planes can be scanned by various methods, for instance, by means of a wire-rope sensor at the side plates, an ultrasonic sensor on the existing road surface or a grade-line in combination with rotary transducers. A slope control sensor is available as an optional extra; the required connections are included as a standard feature.

The Multiplex system can also be integrated into the automatic levelling system as an optional extra. It is an equalizing system for longitudinal levelling.

Hydraulic system

Independent hydraulic systems for travel drive, conveyor belts, cooler fan drive, paving unit, water spray system and setting functions (cylinders). The hydraulic pumps are driven by the diesel engine via a splitter gearbox.

The entire system is filtered via a return-flow suction filter.

The oil for the cylinder functions is additionally passed through a pressure filter.

Electrical system

24 V electrical system with starter, 3-phase alternator and two 12 V batteries, as well as socket outlets for lamps.

Filling

Water is filled via a C-pipe connection or a large filling port.

Diesel fuel is filled via a large filling port.

Safety features

The machine can be securely lashed onto a low-bed trailer or loaded by crane with the aid of lashing lugs.

The comprehensive working and safety lights and a freely positionable lamp with magnetic pedestal provide sufficient illumination, thus ensuring that the machine can be operated safely, even in inclement weather.

Special equipment: Folding discharge conveyor

Dimensions in mm

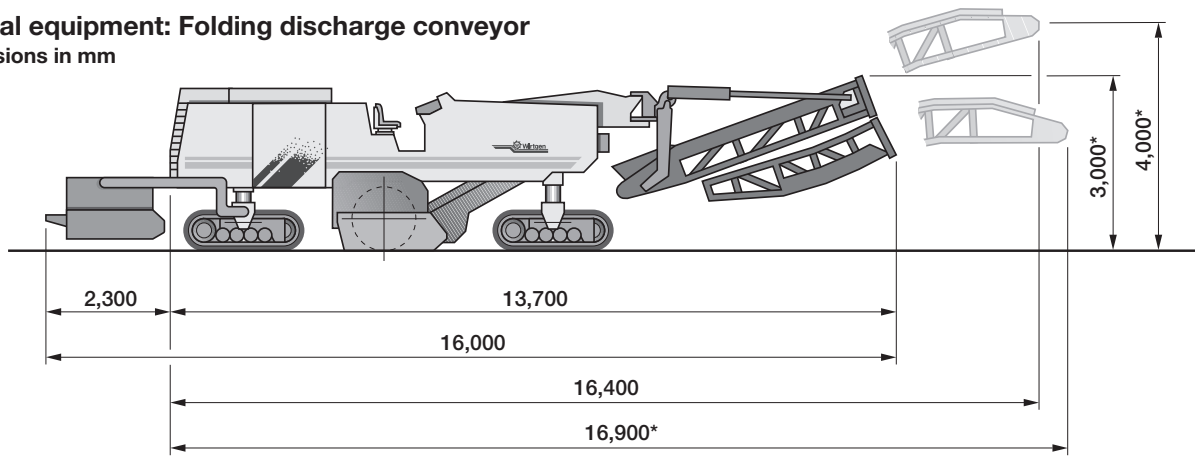

* = Dimensions for low-loader transport

Special equipment: Canopy

Dimensions in mm

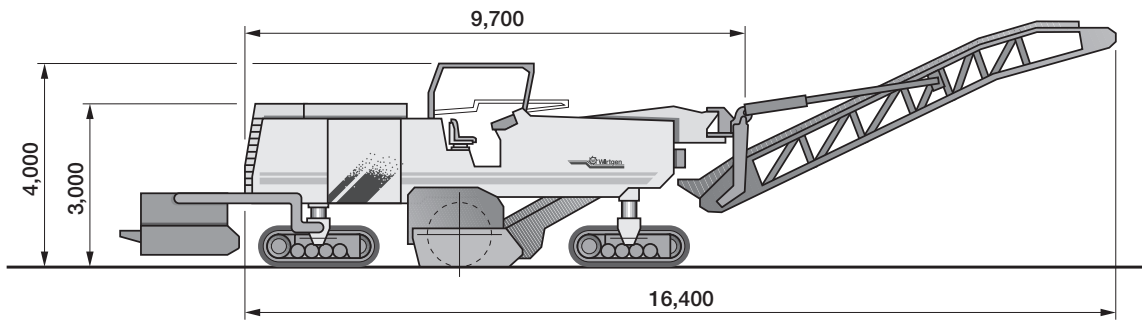

Equipment	Cold Recycler 3800 CR
Frame/Operator's platform	
Pivoting and shifting control consoles	○
Special painting	●
Canopy with front and rear screen, hydraulically retractable	●
Exterior rear view mirrors	○
Travel drive	
4-track steering	○
Hydraulically governed crawler track tension	○
Machine control and levelling system	
Automatic levelling system with wire-ropes or ultrasonic sensor	○
Sensors for scanning a grade-line	●
Multiplex system threefold or sevenfold	●
Slope control sensor	●
Milling drum assembly for down-milling mode	●
Milling drum assembly for up-milling mode	○
WIDIS 32 (Wirtgen information and diagnosis system)	●
Milling drum	
Quick-change toolholder system HT11	●
Additional lock-valve for scraper blade	●
Gradation control beam	●
Hydraulically lifting side plates	●
Pneumatic knock-out tool	●
Hydraulic drum turning device (for cutting tool replacement)	●
Cold recycling system	
Injection system with 1 pump and 1 injection bar	○
Injection system with 1 pump and 2 injection bars	●
Injection system with 2 pumps and 2 injection bars	●
Injection system for foamed bitumen with 2 pumps and 2 injection bars	●
Injection bar (without pump, for use with WM 1000)	●
Hot-bitumen hose for connection to bitumen tanker, various lengths	●
Hose for the transfer of water-cement slurry (without pump)	●
Paving unit	
Spreading auger with scraper	●
Variable screed with tamper	●
Hydraulically openable side plates	●
Ultrasonic sensors for screed control on one side, including digital controller	●
Slope controller for steering the variable screed	●
Loading the milled material	
Material guiding system, including flap to close the front drum door	○
Conveyor belts to load the milled material, 1,100 mm wide	○

○ Standard ● Option

Equipment	Cold Recycler 3800 CR
Frame/Operator's platform	
Exterior rearview mirror right, left and at rear	○
Machine control and levelling system	
Multiplex system with either 3 or 7 sensors	●
Loading the milled material	
Material guiding system, including flap to close the front drum door	○
Conveyor belts to load the milled material, 1,100 mm wide	○
Adjustable discharge conveyor belt speed	●
Hydraulically lifting primary conveyor	●
Conveyor support legs for low-loader transport	●
Hydraulically folding discharge conveyor	●
Miscellaneous	
Temperature-governed cooling system	○
Soundproofing	○
Cyclonic air filter	●
Working lights (detachable)	○
Warning lights	○
Horn and reversing horn	○
Towing device	○
Loading and lashing lugs	○
Comprehensive tool kit	○
Safety certificate by the Employer's Liability Insurance Association	○
Comprehensive safety package with 6 emergency stop buttons	○
Compressed air system	●
Rear water filling port	●
High-pressure water wash down	●
Hydraulically operated pump for water refilling	●
Operation of the cold recycler with organic hydraulic fluid	●

○ Standard ● Option



Wirtgen GmbH
Reinhard-Wirtgen-Strasse 2 · 53578 Windhagen · Germany
Phone: +49 (0) 26 45/131-0 · Fax: +49 (0) 26 45/131-242
Internet: www.wirtgen.com · E-Mail: info@wirtgen.com